

DC Grid Efficiency for Home Owners Associations

DUE 2015, April 1st, Cape Town



The Hague University of Applied Sciences
Electrical Engineering (TIS-Delft)
Focusgroup 'Energy in the build environment'
Ing. Pepijn van Willigenburg

THE HAGUE
UNIVERSITY OF
APPLIED SCIENCES

Contents

- 1 Introductions
- 2 DC-Grid models
- 3 Simulations & Results
- 4 Discussion
- 5 Contact information



Introductions



Personal Introductions

- Pepijn van Willigenburg
- Bachelors Degree in Management of Technology
- Researcher for Entrepreneurship & Innovation
- Project manager & proposal writer

Introductions



Programme Introductions

- DC is making a comeback
- Educational and Research Programme
 - ‘DC: Road to its full potential’
- Long term goals
 - Improvement of Curriculum
 - Staff Professionalization
 - Industry partnerships (e.g. Siemens, ABB)
- Research WP 3.2
 - Can we redesign an electrical grid with smaller, smart, perhaps autonomous building blocks?

Introductions



Introduction to the Topic: Home Owners Associations

- Dutch Energy Agreement
 - Green Growth
- Legislation for pilot energy networks
 - Allowing for unconventional solutions as for example more than 1 grid connection.
- More than 100,000 HOA's in Netherlands
 - Made up of two to dozens of apartments
 - 600,000 households

Can HOA rooftops be used for 'community utilized PV generation'?

DC-Grid models



Research Questions

- Does a centralized and dynamically parallel operated DC-DC conversion offer efficiency benefits compared to a decentralized lay-out?
 - Q1
- Does a centralized PV-system offer benefits compared to a similarly dimensioned but decentralized PV-power supply?
 - Q2

DC-Grid models



Models for conversion comparisson (Q1):

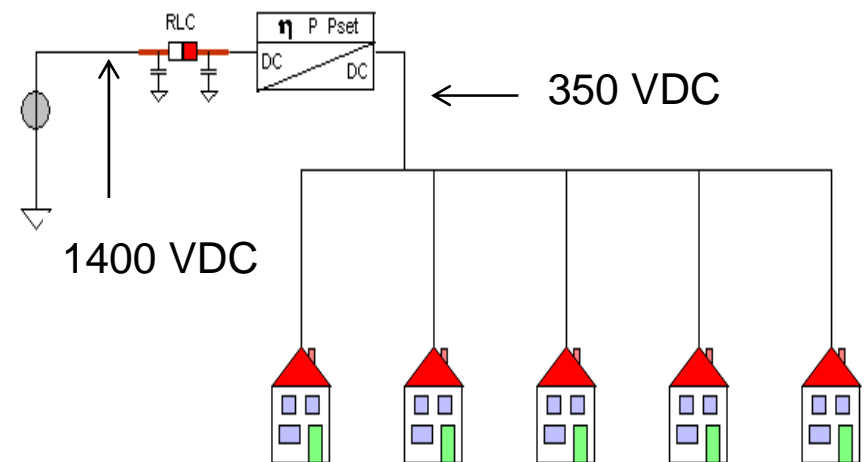
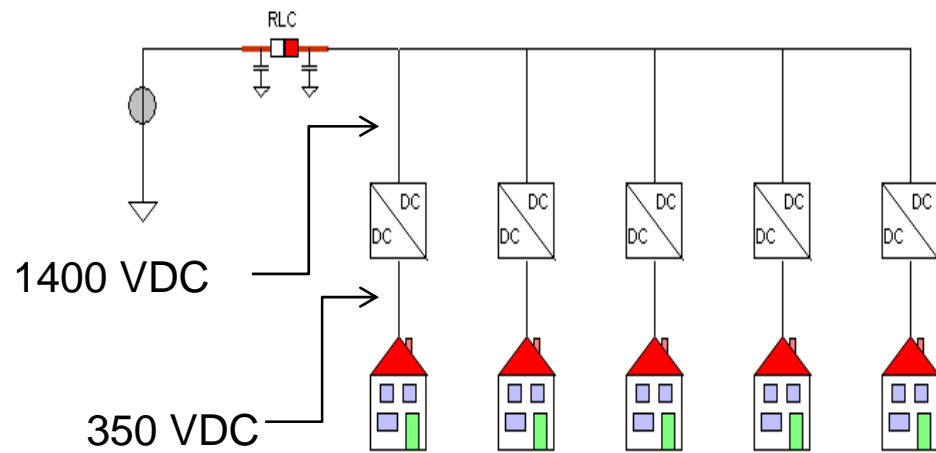

DC – road to its full potential

DC-Grid models



Models for PV-power supply comparisson (Q2):

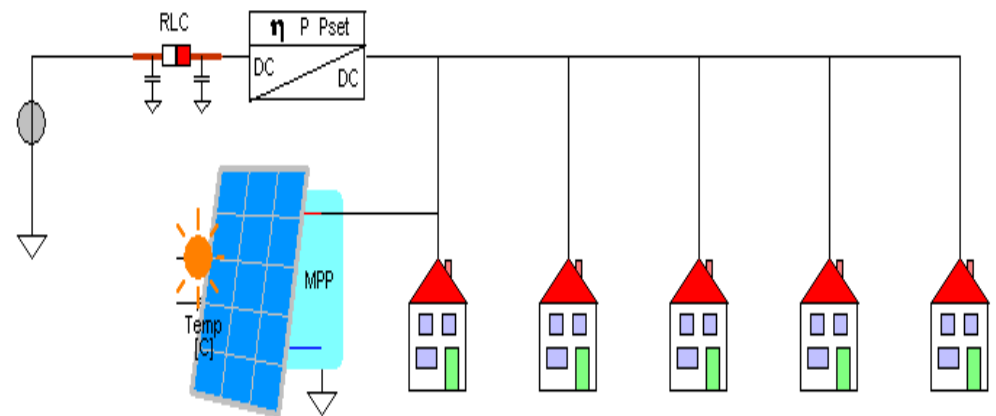
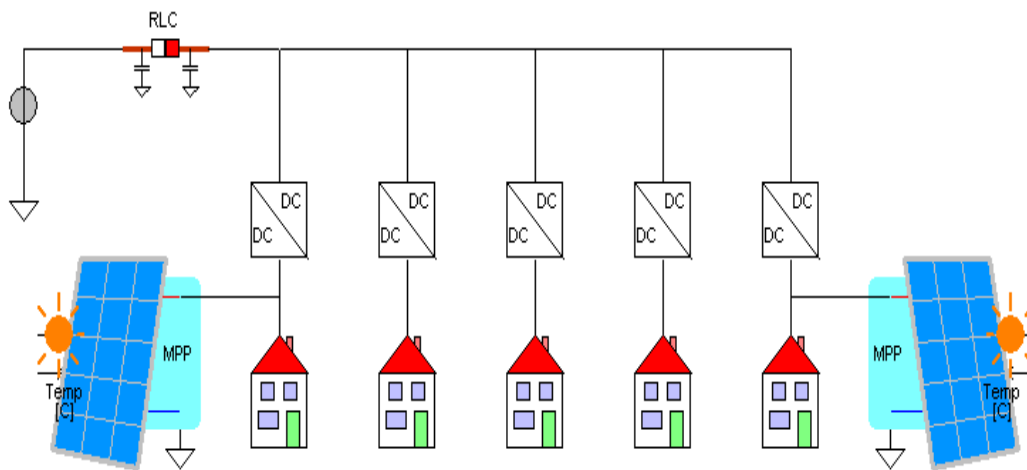

DC – road to its full potential

Simulations & Results



Simulations set-up

- Caspoc (simulation programme)
- Each household to consume 3350 kWh yearly
 - Data from Germany (Nurnberg Area)
 - Day/night, week/weekend and seasonal variations
- PV supply system 6.8 kW_{peak}
 - Systems yields roughly 1100 kWh per kW_{peak}
 - Comparable with yield in Nurnberg Area

Simulations & Results



Simulations set-up

- Efficiency Curves DC-DC converters

← Single

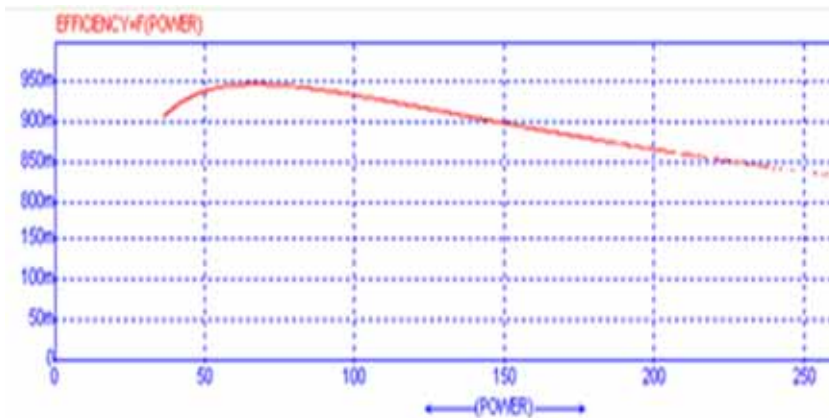

Scalable setup →

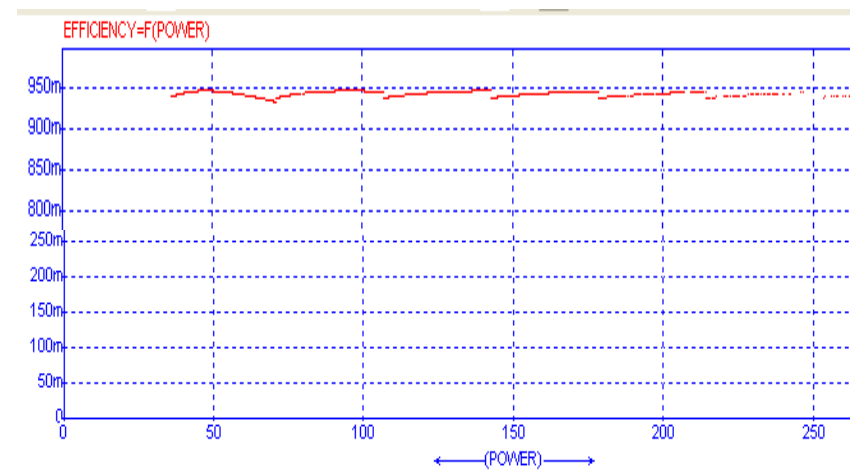

Simulations & Results



Results Q1: Centralized DC-DC conversion is 4% more efficient

- 92.5% vs 96.6%
- 5 households need 16.75 MWh
- Grid usage decentralized system 18.09 MWh
- Grid usage centralized system 17.33 MWh

This results is in line with expectations. This result alone is however insufficient to make centralized DC-DC conversions as the preferable design option.

Simulations & Results



Results Q2: Centralized PV-power supply is 13% more efficient

- 5 households need 16.75 MWh
- Grid usage decentralized system 11.20 MWh
- Grid usage centralized system 9.72 MWh
- Maximum improvement: $18,09 - 9,72 = 8.37$ MWh
 - Improving yearly yield per kW_{peak}

This results is in line with expectations, as PV-power needs to pass DC-DC converters twice in the decentralized system: $0.925 * 0.925 = 0,855$. Is that enough to make the centralized system favorable?

Discussions



- Results: How to compare with AC?
 - Very different grid structure and voltage levels
- Results: Is a gain of, in this case, 1.5 MWh for 5 households, enough to be a solid basis for grid design choices?

Discussions



- Interpretation results for WP 3.2
 - Results indicate a increase in grid efficiency when offering households centralized facilities combining PV-supply and a scalable DC-DC converter
 - We think that DC Grid building block will become smaller than in AC-Grids (100's households)
 - More research needed, to better compare distribution losses (distances vs conversions)

Decrease in efficiency due to longer distribution distances

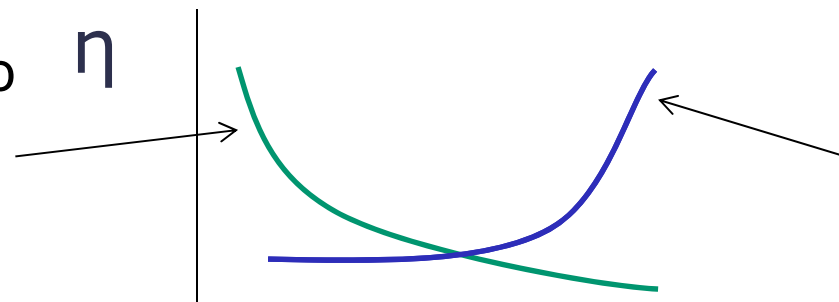

Increase in efficiency due to less conversion points and more effective converters

Discussions



Questions please?

Contact Information



The Hague University of Applied Sciences
Academie TIS-Delft
Rotterdamseweg 137
2628 AL Delft
p.vanwiligenburg@hhs.nl
+31-6-48279102