



Stakeholders involved in the deployment of microgeneration and new end-use technologies

Subtask 7 Report

Jussi Ikäheimo

Göran Koreneff

VTT Technical Research Centre of Finland

in co-operation with the country experts

International Energy Agency Demand-Side Management Programme

Task XVII: Integration of Demand Side Management, Distributed Generation, Renewable Energy Sources and Energy Storages

Operating Agent:

Seppo Kärkkäinen
Elektraflex Oy, Finland
Tel: +358 50 555 1207
seppo.karkkainen@elektraflex.com

Country experts

Matthias Stifter	Austria	AIT Austrian Institute of Technology – Energy Department (matthias.stifter@ait.ac.at)
Peter Palensky	Austria	AIT Austrian Institute of Technology – Energy Department (peter.palensky@ait.ac.at)
Rusbeh Rezania	Austria	Vienna University of Technology – Energy Economics Group (rezania@eeg.tuwien.ac.at)
Samuli Honkapuro	Finland	Lappeenranta University of Technology - Department of Energy and Environmental Technology (samuli.honkapuro@lut.fi)
Jarmo Partanen	Finland	Lappeenranta University of Technology - Department of Energy and Environmental Technology (jarmo.partanen@lut.fi)
Dominique Fournet	France	ADEME (dominique.fournet@ademe.fr)
Vincent Krakowski	France	ADEME (vincent.krakowski@ademe.fr)
Nouredine Hadjsaid	France	Grenoble Institute of Technology - The research center G2Elab (hadjsaid@g2elab.grenoble-inp.fr)
Jean-Christophe Maisonobe	France	Grenoble Institute of Technology - The research center G2Elab (jean-christophe.maisonobe@g2elab.grenoble-inp.fr)
René Kamphuis	Netherlands	Energy Research Centre of Netherlands (ECN)/ since 2011TNO (rene.kamphuis@tno.nl)
Andre Postma	Netherlands	Enexis (andre.postma@enexis.nl)
Miguel Ordiales Botija	Spain	Red Eléctrica España (mordiales@ree.es)
Asier Moltó Llovet	Spain	Red Eléctrica España (asier.molto@ree.es)

Operating Agent

Seppo Kärkkäinen	Finland	Elektraflex Oy (seppo.karkkainen@elektraflex.com) with the assistance of
Jussi Ikaheimo	Finland	VTT Technical Research Centre of Finland (jussi.ikaheimo@vtt.fi)
Göran Koreneff	Finland	VTT Technical Research Centre of Finland (goran.koreneff@vtt.fi)
Juha Kiviluoma	Finland	VTT Technical Research Centre of Finland (juha.kiviluoma@vtt.fi)



EXECUTIVE SUMMARY - Stakeholders involved in the deployment of microgeneration and new end-use technologies

TASK XVII: INTEGRATION OF DEMAND SIDE MANAGEMENT, DISTRIBUTED GENERATION, RENEWABLE ENERGY SOURCES AND ENERGY STORAGES

Task extension: The effects of the penetration of emerging DER technologies to different stakeholders and to the whole electricity system

Background Energy policies are promoting distributed energy resources such as energy efficiency, distributed generation (DG), energy storage devices, and renewable energy resources (RES), increasing the number of DG installations and especially variable output (only partly controllable) sources like wind power, solar, small hydro and combined heat and power.

Intermittent generation like wind can cause problems in grids, in physical balances and in adequacy of power.

Thus, there are two goals for integrating distributed energy resources locally and globally: network management point of view and energy market objectives.

Solutions to decrease the problems caused by the variable output of intermittent resources are to add energy storages into the system, create more flexibility on the supply side to mitigate supply intermittency and load variation, and to increase flexibility in electricity consumption. Combining the different characteristics of these resources is essential in increasing the value of distributed energy resources in the bulk power system and in the energy market.

This Task is focusing on the aspects of this integration.

Objectives The main objective of this Task is to study how to achieve a better integration of flexible demand (Demand Response) with Distributed Generation, energy storages and Smart Grids. This would lead to an increase of the value of Demand Response, Demand Side Management and Distributed Generation and a decrease of problems caused by variable-output distributed generation (mainly

based on renewable energy sources) in the physical electricity systems and at the electricity market.

Approach

The first phase in the Task was to carry out a scope study collecting information from the existing IEA Agreements, participating countries with the help of country experts and from organized workshops and other sources (research programs, field experience etc), analyzing the information on the basis of the above mentioned objectives and synthesizing the information to define the more detailed needs for the further work. The main output of the first step was a state-of-the art report.

The second phase (Task extension) is dealing with the effects of the penetration of emerging DER technologies to different stakeholders and to the whole electricity system. The second phase concentrates on DER at consumer premises.

The main subtasks of the second phase are (in addition to Subtasks 1 – 4 of the phase one):

Subtask 5: Assessment of the DER technologies and their penetration in participating countries

Subtask 6: Pilots and case studies

Subtask 7: Stakeholders involved in the penetration of the DER technologies at consumer premises and effects on the stakeholders

Subtask 8: Assessment of the quantitative effects on the power systems and stakeholders

Subtask 9: Conclusions and recommendations

The figure below describes the concept of this extension.

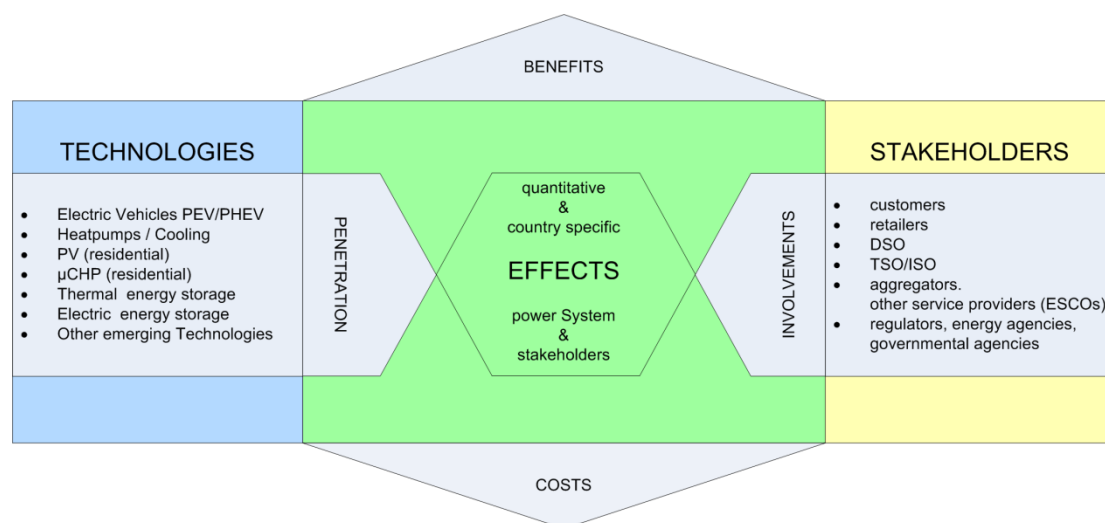

Results

The report discusses different stakeholders involved in the penetration of microgeneration and new end-use technologies, as well as effects on the stakeholders. Microgeneration includes e.g. solar power (photovoltaics and

concentrated solar power), small wind turbines and micro-CHP; new end-use technologies include heat pumps and electric vehicles with smart charging. The characteristic for these technologies is that they are installed at the consumer's premises and generate power mainly for the consumer himself. We also considered the rough power limit for microgeneration to be 50 kW_e.

We identify a number of stakeholders to whom microgeneration and new end-use technologies can present significant effects. Most importantly, the consumer himself, network companies and electricity supplier (retailer) are involved. Network companies may either benefit or suffer from the introduction of microgeneration, heat pumps and EV, depending on the specific technology and how it is used. The consumer can contract an aggregator to sell the microgeneration or reprofiled consumption to competitive energy market participants or network companies. Manufacturers strive to develop more affordable and more efficient generating units, normally with the help of subsidies provided by governments.

The scope of this report is indeed wide. The report reviews the various questions the stakeholders have to consider related to the introduction of the new generation and end-use technologies. Examples include operation of the microgenerators and EV charging systems, communication, effects on power quality, network stability and network capacity, emissions, energy efficiency, etc. In some cases, the questions can turn out to be serious barriers.

It is difficult to draw general conclusions about the costs and benefits to each stakeholder. In each case they depend on the details of technologies and their methods of control, as well as on the stakeholders themselves and the details of contracts between them. Also electricity market rules, regulations and subsidies have a large effect.

The appendices provide some examples of stakeholder involvement from four different countries. Appendix 1 introduces some elements of business models related to EV and smart meters in Spain. Appendix 2 introduces business models for EV charging in Austria. Appendix 3 contains a more detailed analysis of different power-based tariffs from the point of view of the DSO in Finland. Appendix 4 contains a detailed analysis of different stakeholders involved in EV, PV and smart meters in France.

International Energy Agency Demand-Side Management Programme

Task XVII: Integration of Demand Side Management, Distributed Generation, Renewable Energy Sources and Energy Storages

Operating Agent:

Seppo Kärkkäinen
Elektraflex Oy, Finland
Tel: +358 50 555 1207
seppo.karkkainen@elektraflex.com

Table of contents

1	Introduction	1
2	End-users of energy	2
3	Retailers/suppliers	7
4	Aggregators	9
5	Distribution system operators	12
6	Transmission system operators	16
7	Power exchanges	20
8	Regulators and energy agencies (TBC)	21
9	Governments and support schemes	21
10	Summary.....	24

List of abbreviations

ACER	the European Agency for the Cooperation of Energy Regulators
AMM	Advanced metering management
AMR	Automatic Meter Reading
AS	Ancillary Services
BM	Balancing Mechanism
BRP	Balancing Responsible Party
CENELEC	European Committee for Electrotechnical Standardization
CAM	Control area manager
CHP	Combined Heat and Power
CSP	Concentrated Solar Power
DER	Distributed Energy Resources
DG	Distributed Generation
DR	Demand Response
DS	Distributed Storage
DSB	Demand-Side Bidding
DSI	Demand-Side Integration
DSM	Demand-Side Management
DSO	Distribution System Operator
EN	European Standard (developed by European Committee for Standardization)
ENTSO-E	European Network of Transmission System Operators for Electricity
FCL	Fault Current Limiter
HAN	Home Automation Network
HV	High-voltage
IEA	International Energy Agency
IEC	International Electrotechnical Commission

IEV	International Electrotechnical Vocabulary
LV	Low-voltage
PCC	Point of Common Coupling
PV	Photovoltaic (power generation)
RES	Renewable Energy Source
RTP	Real-time Pricing
STATCOM	Static Synchronous Compensator
ToU	Time of Use
TSO	Transmission System Operator
UML	Unified Modeling Language
UPFC	Unified Power Flow Controller
V2G	Vehicle to Grid
VPP	Virtual Power Plant
VTT	Technical Research Centre of Finland
μCHP	Micro Combined Heat and Power

1 Introduction

Microgeneration is the small-scale generation of power by individuals, small businesses and communities to meet their own needs, as alternatives to traditional grid-connected power. It is a subcategory of distributed generation, with the distinguishing feature of low power output (in this report we assume a rough limit of 50 kW_e, inspired by the EU Directive 2004/8/EC which defines this limit for micro-CHP) and the power is largely spent by the generator himself. The microgeneration technologies have been discussed in subtask 5 of IEA DSM task 17, and include e.g. micro-CHP (fuel cells, microturbines, stirling engines, internal combustion engines etc.), micro combined cooling, heating and power (μ -CCHP), small wind turbines, photovoltaic solar panels and micro-scale hydro power. New end-use technologies in this report include different types of heat pumps and plug-in electric vehicles, both of which significantly change consumers' electricity demand patterns.

In this task we have prepared separate reports about the different microgeneration technologies, heat pumps, electric vehicles and smart meters. These provide an overview of the current status of these technologies. The current situation and future scenarios in the participating countries is also reviewed. In this report we thus do not pay too much attention on the technology aspects. Instead we take a different point of view and try to see what consumers, network companies, electricity suppliers and other stakeholders wish to take into consideration when more and more of these new technologies are installed.

There are many actors involved in distributed energy business and new end-use technologies, all of which have their own goals. For example, end-users look for the cheapest means to satisfy their energy needs. On the other hand, for DSO it is important to ensure employee safety, network reliability and power quality. The effects of microgeneration and new end-use technologies on different stakeholders are also different, and they depend on the specific technology as well as the *business models* which are applied in financing the investment and sharing the risks and benefits. This report discusses different stakeholders involved in the penetration of microgeneration and new end-use technologies. The stakeholders include:

- end-users of energy,
- retailers and aggregators,
- distribution system operators (DSO) ,
- transmission system operators (TSO),
- fuel suppliers,
- technology manufacturers,
- system integrators,
- telecom companies,
- remote monitoring and maintenance service providers,
- real estate developers,
- installers.

These are stakeholders who take part in the business activities related to microgeneration and new end-use technologies. There are stakeholders which do not take part in business but are otherwise involved. These include

- regulators/energy agencies/governmental agencies,
- standard developers and
- society as a whole.

The risks and benefits in installing and operating microgeneration can be arranged in different ways. This leads us to the concept of business model. By "business model" we mean a description of the partners, main transactions, sources of value, and incentives of a business interactions (Akkermans, Gordijn 2006). The interactions between different stakeholders are a component of business models. They are not simple value chains but value constellations in which enterprises are collaborating in networks. The introduction of changes into this system can have a negative or positive effect on the well-being of different actors. Negative effects to some actor can jeopardize or delay the follow-through of the changes.

This report describes the issues which each stakeholder should consider due to penetration of microgeneration and new end-use technologies, as well as the involved risks and benefits.. We start by consumers in Chapter 2, study the position of retailers and aggregators in Chapter 3 and 4, continue with system operators (DSO and TSO) in Chapters 5 and 6. These are the key stakeholders involved. Power exchanges are briefly mentioned in Chapter 7, regulators in Chapter 8 and governments in Chapter 9.

Appendix 1 of this report introduces some elements of business models related to EV and smart meters in Spain. Appendix 2 introduces business models for EV charging in Austria. Appendix 3 contains a more detailed analysis of different power-based tariffs from the point of view of a Finnish DSO. Appendix 4 contains an analysis of different stakeholders involved in EV, PV and smart meters in France.

2 End-users of energy

We concentrate on end-users who connect to the low-voltage grid. They include residential consumers such as single-family houses, row houses or apartment buildings; hospitals, retail stores or office buildings; or small industrial customers. In this report we use the term consumer also for consumers who have installed or are considering to install microgenerators or distributed storages such as EV.

The motivations and responsibilities of the end-user are different depending on the ownership of the building, apartment or office. The end-user can own the premises or be a tenant. The tenant may be responsible for energy bills. In some cases, however, there is no separate electricity meter for the tenant. In this case the electricity consumption is estimated e.g. based on the floor area which the tenant occupies, which reduces the incentives for energy saving or demand response. The owner of the building ultimately makes the decision to install microgeneration units, heat pumps, or support for plug-in electric vehicles into an existing building. If the owner himself is not the energy end-user, such as in case of landlords, he does not have the incentive to save energy. However, the EU directive 2002/91/EC, concerned with energy efficiency of buildings, specifically mentions rented buildings with the aim of ensuring that the owner, who does not normally pay the charges for energy expenditure, should take the necessary action.

The primary goal for energy end-users is to have an energy supply (heating, cooling and power), which is

- affordable,
- reliable,
- simple to install and manage,
- environmentally friendly,
- producing a high-quality indoor environment.

Microgeneration technologies usually cannot reach grid parity (successfully compete with grid power) at this moment, thus they cannot increase affordability of energy as such. This statement should be taken as a general guideline. For example PV is expected to reach grid parity from the consumer point of view in Germany in a few years. This situation can occur in countries with high retail rates and high level of insolation (Olson, Jones 2012). Combination of the building load profile and fuel and electricity prices will strongly affect economic benefits. End-user incentives during peak hours, such as real-time pricing or critical peak pricing can increase the attractiveness. Buildings with high heating loads are the most attractive for μ -CHP installation from economic point of view (Norwood et al. 2010). Those with cooling loads are economically less attractive because of the high cost of CCHP systems. In any case, the investor can significantly benefit from an in-depth analysis of the installation, including heat and power consumption profiles, building characteristics, readiness of consumers to sacrifice comfort (EU DEEP 2009).

However, different support schemes are used to increase the benefits of renewable microgeneration and micro-CHP. These depend on the type of technology, size of the unit and the time when it is installed, and of course on the country in question. The different support schemes are discussed in context with government agencies. Some types subsidies, such as feed-in tariffs, may not help with the required initial investment, which can be quite high. In new buildings more options are available for installing microgeneration or heat pumps. But especially private home builders are normally short of funds and avoid additional debt, so any additional investments are scrutinized thoroughly and should be very attractive. A different business model, where another party takes care of the investment and takes part of the savings of energy bill or revenues of energy sale, could be a remedy.

Heat pumps on the other hand can in many cases be profitable without subsidies. The profitability depends on the alternative heating system to which the heat pump is compared, as well as the type of heat pump, and local climate conditions. The consumer evaluates profitability of electric vehicles mainly from the point of view of transportation, i.e. compared to traditional vehicles with internal combustion engine, although they can also contribute to the building energy supply, and provide ancillary services to the grid.

One aspect of affordability is the space requirement of heat pumps or microgeneration units. Residents or users of the building must find the space for the equipment, as well as the possible fuel storage. The space requirement should be compared to that of the system which is replaced. For example, roof-top solar panels do not require any additional space and the power conditioning equipment take only little space. Many μ -CHP units of 1 kW_e power, for example, are equal in size to a dishwasher. In case of μ -CHP which feeds on biomass, a sizable fuel storage is needed. For example in subarctic climates a wood pellet storage bin for single-family house should hold up to 15 m³.

An important development trend in the building sector is the increasing energy efficiency, and thus reduced need for heating and cooling. In energy-efficient buildings, warm and cool spaces (such as supermarket refrigerator cases) are better insulated and free energy such as

solar radiation and waste heat are better utilized. Unfortunately, this decreases the attractiveness of μ -CHP installation because during large part of the year there is no heating load (or cooling in case of CCHP), which the μ -CHP could satisfy. This has been illustrated in Figure 1, which shows that in cool climates the need for purchased energy is reduced drastically when energy efficiency increases. If the building is electrically heated, high energy efficiency decreases power consumption, and thus the need for locally produced electricity.

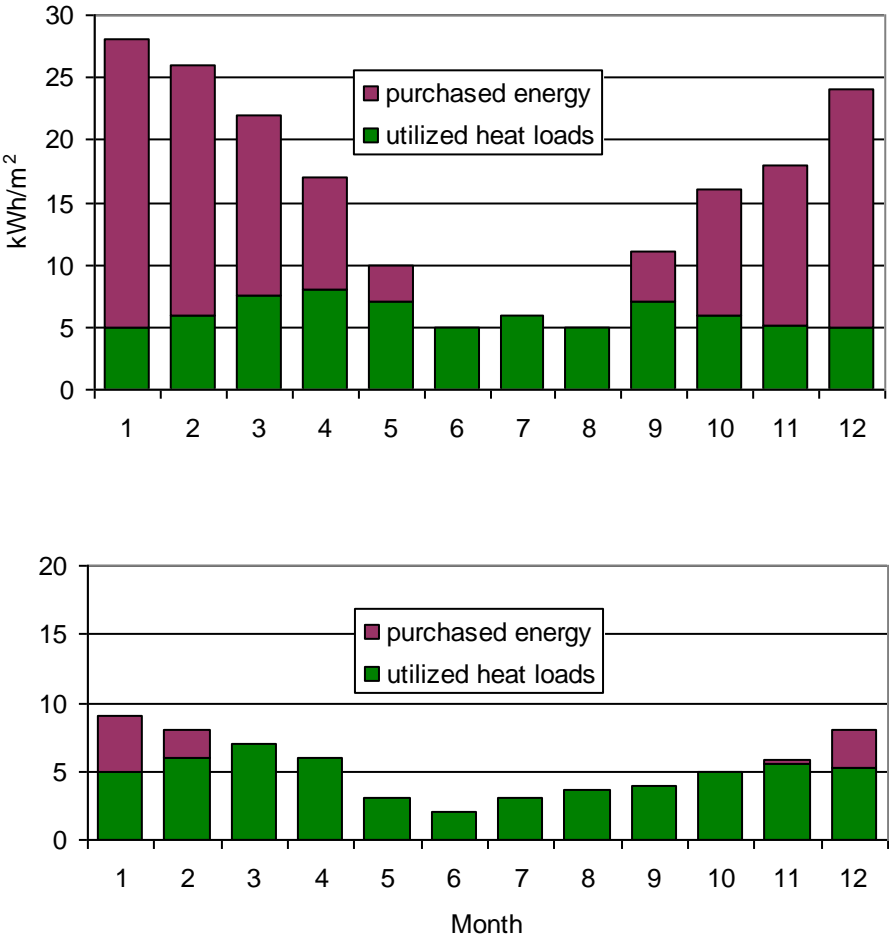

Figure 1: According to this simulation the need for purchased heating energy is reduced to 3–4 months a year in the energy-efficient building (lower graph) in the climatic conditions of southern Finland. The upper graph shows the heating energy demands for a reference building (Similä 2009).

Microgeneration, especially dispatchable technologies, together with small energy storages can increase the reliability of energy supply. At times when grid power is not available, power can be supplied from the microgeneration unit or local energy storage, though normally at higher cost than grid power. In other words, they can act as back-up generators and replace possible existing diesel generators. Of course, this requires that the equipment required to set up a working system for an off-the-grid generation have been installed. These include at least an inverter and a transfer switch to reconnect electric power source from its primary source to the a stand-by source, so that a local generation or storage unit can replace a utility source. Quality of the power supplied by the inverter should be sufficient to prevent various electrical appliances from suffering from the effects of e.g. harmonic frequencies.

Naturally, increased reliability does not come without cost: fuel supply and maintenance for the microgeneration units should be secured. Some equipment such as solar panels and small wind turbines may attract thieves, and theft cases have been reported in some countries. Also, if consumers rely more and more on local generation and purchase less power from the grid, there is a risk that the distribution grid is allowed to deteriorate, thus decreasing reliability of energy supply.

Microgeneration and new end-use technologies are in many cases more complicated to manage than traditional utility-supplied power and heat. They introduce additional pieces of equipment, which require learning and maintenance. This depends on the specific technology though. For example, it has been estimated that ground-source heat pumps require less attention from the residents than natural gas boilers. With aging population in Europe, simplicity of operation should be among the primary goals. User interfaces should be easily understandable and intuitive. The equipment should perform self-monitoring and when possible, inform the users about maintenance needs ahead of time.

Installation of microgeneration can be complicated. Consumers are not well aware of microgeneration, its advantages and costs. In a recent study it was found that customer knowledge is critical for bringing DER to the markets with the help of aggregator companies (EU-DEEP 2009). The consumer should be at least summarily aware of the regulations concerning installation of microgeneration and heat pumps, as well as available subsidies and the procedure to apply them. It is then important that the regulations and procedures are simple to avoid overloading the average consumer with bureaucracy.

Also many HVAC installers are not very experienced with these systems. Consumers are understandably cautious and also vulnerable to poorly installed systems. The problem of lack of skilled installers has also arisen in some countries due to soaring popularity of heat pumps. Installation of especially μ -CHP and ground source heat pumps can be problematic in existing buildings because a central heating system using water circulation is preferred. It is possible to install these in buildings with forced-air heat distribution but in this case a larger heat exchanger is needed. The installer should be aware of the procedure which the DSO requires in installation of microgenerating units. This procedure should be simple and uniform from one DSO to another.

Especially private consumers are not driven solely by economic motivations. They also wish to pursue environmentally friendly ways of living. This includes attempts to reduce amounts of waste, energy use, and various emissions. During the past decade the media has emphasized reducing CO₂ emissions. Yet many people remain unaware of how they could make changes in their own lives to reduce emissions (Environment Canada 2006). Enabling people to generate clean, affordable energy in their own homes and businesses allows them to understand their own energy use and be proactive in reducing their emissions (CRC Research).

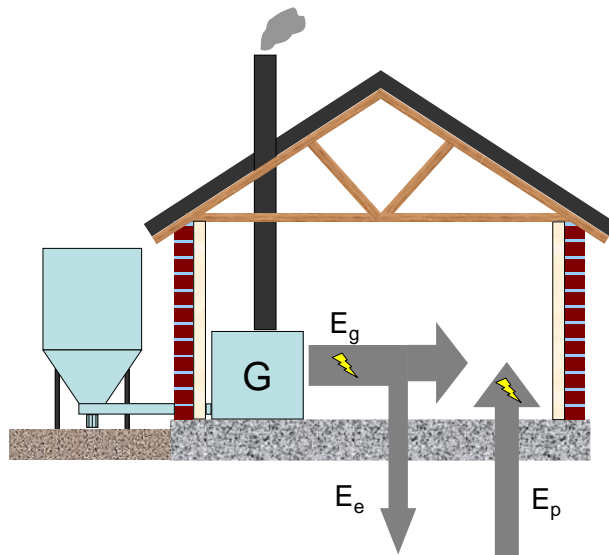

Figure 2: A microgeneration unit (G) can generate power for the consumer’s internal use or for export to the grid (E_e). These sum to total energy generated E_g . In the picture, energy E_p is purchased from the grid. Metering requirements for E_g , E_e and E_p can vary among countries and consumer types.

However, some μ -CHP technologies, for example those combusting wood pellets, generate emissions including nitrogen oxides, polycyclic aromatic hydrocarbons and particulate matter. These pollutants can be much more efficiently controlled in large power stations, which also spread the pollutants on large, partly uninhabited areas. It is also possible that μ -CHP increases emissions, in case when the carbon intensity of power generation in the electrical system is very low. Fuel cells produce less carbon monoxide and much less nitrogen oxides than gas-fired condensing power plants. Heat pumps do not produce emissions.

The end-user ultimately controls the operation of the dispatchable microgeneration unit, heat pump or EV charging and discharging (in case of V2G operation). To make the control schedules coherent with the needs of energy markets and the grid, the end-user may receive different types of incentive signals from his retailer or aggregator. Direct control of the units is sometimes performed by an aggregator but to better account for the local conditions the final control decision should be done by the end-user. In all cases the end-user should have the possibility to override even direct control signals.

Different operating strategies are possible for especially micro-CHP units. Heat-led operating strategy tries to meet onsite heat demand using the direct thermal output of a micro-CHP unit. The presence of a heat storage can allow running the μ -CHP closer to its optimal operating point, for example reducing the need to run an integrated condensing boiler. Electricity led operating strategy is defined as dispatching the unit with the intention of meeting as closely as possible the onsite electrical load. Excess thermal energy is stored in the heat storage or dumped as a last resort. If heat output is not enough to cover the heating load, the heat storage is discharged first, followed by the start-up of the possible integrated condensing boiler (Leach, Hawkes 2007). Of course, a heat pump, when present, can also act as a heat source in the electricity-led operating strategy. Finally, the least-cost operating strategy minimizes the cost of meeting the heat load subject to technical constraints of the system. Electricity can be imported and exported and heat storage charged and discharged according to fuel prices and electricity import and export prices. It is also possible to devise an emission-minimizing operating strategy, or include emissions as one cost component in least-cost operating strategy.

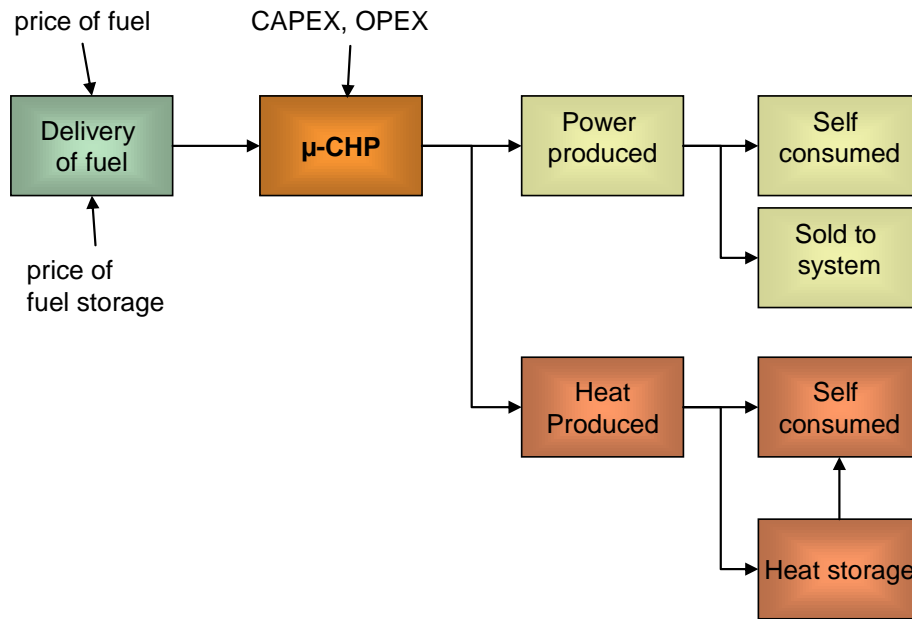

Figure 3: Pathways of energy conversion with μ -CHP .

Regardless of the strategy, the end-user should set suitable limits for the temperature comfort zone to which he is accustomed. The user interface of the control device should provide an intuitive way of doing this. A simple slider control, which allows more comfort in the one end and more temperature variations but more savings in the other end has been suggested.

Indeed, healthy and comfortable indoor environment is important for end-users. They will consider the fact that small wind turbines and some μ -CHP types produce noise, which reduces living comfort. Regarding air-to-air heat pumps there has been some discussion about the detrimental effects to air quality when they are used for cooling. There can be dust and moisture build-up inside the unit, providing conditions for mould growth. This again reminds us of the fact that consumers should learn to maintain the new types of equipment.

3 Retailers/suppliers

Retailer (we use the word as synonym to “supplier”) is the deregulated power system participant who sells the electricity to the end-user. He receives the revenue from electricity sales to end-users, and on the other hand, has to procure the electricity from the wholesale market, usually on hourly or half-hourly basis, or generate the electricity himself. Retailer thus communicates with a passive consumer and on the other hand the power wholesale market. In some market models the retailer can even be the single point of contact for the end-user, so that in most matters he deals with the retailer and rarely with the DSO. The retailer in turn relays the matter to the DSO, acting as a middleman between the end-user and DSO. In other market models the consumer contacts the DSO directly for various matters. Nordic regulators association Nordreg has set the single point of contact model (but not in the pure form) as the target model for Nordic countries.

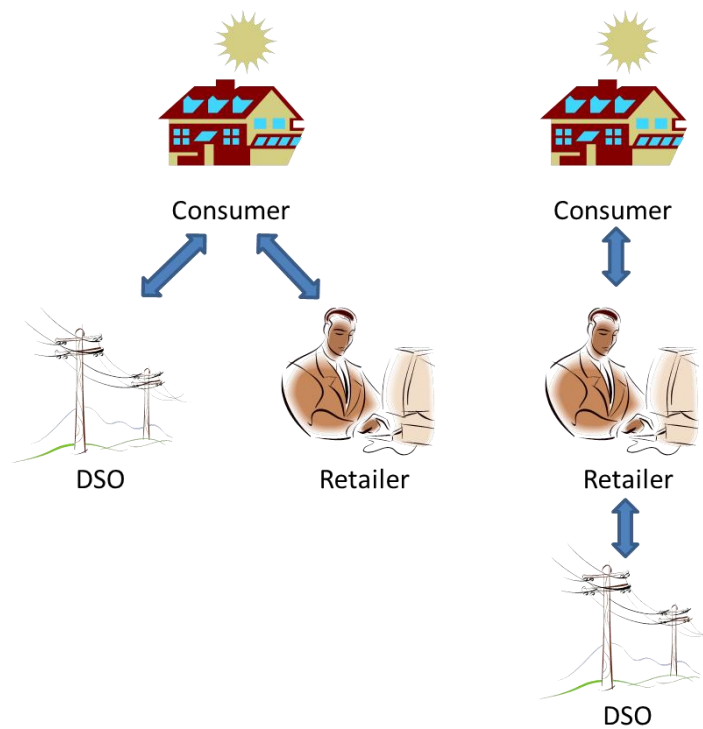

Figure 4: The consumer may deal with both the DSO and the retailer (left) or only the retailer (right).

A retailer has to consider effects of the new energy technologies on the following topics:

- sales volume,
- retail and wholesale prices,
- retail volumes
- energy imbalances and balancing costs,
- ICT systems.

Microgeneration makes consumers more self-sufficient and decreases the amount of electricity which consumers need to buy from the grid and thus also retailers' sales. Independent retailers normally operate with small profit margins and lean organization. Decreasing sales could cause problems to many independent retailers. EV's on the other hand increase electricity consumption and retailers' sales.

In the future local generators may be able to sell their excess production in the market via retailers. The retailer would then procure electricity not only from the market but also from consumers themselves. Undoubtedly the retailer could charge a margin from the consumer who acts as producer for selling the excess energy on the market.

In many European countries the retailer has to cover the deficit or surplus in the balance between power generation, trade, and consumption by end-users, by buying or selling balancing power. The prices of balancing power are set less favourable than prices on organized electricity markets by the balance settlement responsible party and thus the retailer suffers an economic loss for any imbalance. This means that it is very important for the retailer to be able to accurately forecast the level of consumption of his contracted customers. This forecast should be accurate on hourly, half-hourly, or 15 minutes resolution depending

on country. Consumption forecasting is an established branch of science but microgeneration and new end-use technologies require new models to be added in the forecasting tools.

4 Aggregators

The traditional retailer cannot fully serve “active consumers”, who can provide DR or has installed microgenerators or energy storages (such as EV). Current research suggests that empowering electricity consumers by giving them financial rewards for changing their consumption behaviour requires new types of business functions. The purpose is to enable consumer exposure to electricity markets in an efficient way. These functions can be taken care of by an independent organization or an existing market participant, e.g. an electricity supplier (retailer). In each case, we call this organization an *aggregator*. We also use the term *retailer-aggregator* when we want to emphasize the case that the aggregator also acts as retailer. The terms *demand aggregator* (collecting together DR) or *generation aggregator* (collecting together DG) can also be used. We thus define the aggregator in the following brief way:

An aggregator is a company who acts as intermediary between electricity end-users, who provide distributed energy resources, and those power system participants who wish to exploit these services.

There are many synergies between retailer and aggregator activities; aggregator and retailer can be the same company. Aggregators are deregulated power system participants with the main role of bringing DER on markets for the use of the other players, and on the other hand providing market access to DER. Here distributed energy resources (DER) include demand response, distributed generation and energy storages.

In the following the aggregator’s responsibilities are explained and after that we can proceed to discussing how the introduction of microgeneration and new end-use technologies affects aggregators and retailers. Towards consumers and the aggregator (Belhomme et al. 2009):

- 1) studies which consumers or DER owners can provide demand response, distributed generation or distributed storage capacity in a profitable manner,
- 2) promotes and informs the aggregation service to consumers and DER owners,
- 3) provides financial incentives to the consumers or DER owners to provide distributed energy services and
- 4) in some cases acquires and/or installs the control and communication devices at consumer's premises.

Firstly the aggregator has to develop deep knowledge about different types of consumers and their potential as providers of demand response or distributed generation. He has to know the magnitude and cost of demand response that different appliances can provide, as well as other parameters such as time span, storage characteristics and usage constraints (e.g. how many times per week control signals can be sent) of the appliances, storages and generators. Consumers themselves usually have poor knowledge of the flexibility they can deliver (EU

DEEP 2009). In addition the aggregator must study how much inconvenience the control actions cause to the consumers and what kind of compensation the consumers then require.

The aggregator has to make his offer known to the public in an easily understandable way. This is especially true when demand response provision is still a novel business. Later the aggregator does not have to educate consumers about the activity itself, but instead he will try to distinguish himself from other aggregators. If he can make a better offer to a certain group of consumers, it will be of benefit if he informs them about it in an efficient way. The advertising function of the aggregator then benefits the society as a whole.

Consumers should receive signals, control appliances/generators and send measurements in an automated manner. The aggregator can take care of installing the proper control and communication equipment, and, depending on the business models, even microgenerators. Smart meters along with their communication and possible load control features can be exploited in this function. However, these features have not been standardized. Also the measurement resolution may not be high enough and time delay of load control calls may not be low enough for the aggregator's purposes.

Finally the aggregator provides financial incentives to the consumers to participate in demand/generation response. These could take many forms and there are many ways to set up the business. The consumers could be rewarded by being offered an availability payment, call payment (payment for flexibility energy provided), or percentage of the aggregator's profits. The aggregator monitors the consumer's performance and rewards him accordingly.

Towards power system participants and the electricity market the aggregator

- 1) provides distributed energy services in different forms (different timeframes, power curve shapes and locations),
- 2) forecasts the needs for different types distributed energy services on different markets,
- 3) makes sure (together with DSO) that that the provision of services complies with the operation of distribution grids.

The aggregator actively offers the distributed energy resources to the disposal of other power system participants. This can take place through on one-to-one basis by making bilateral contracts or through organized markets by submitting offers to these markets. The buyers include regulated participants such as TSO and DSO's, and deregulated participants such as retailers, generators, traders and BRP's. The requests can be send directly to the aggregator if it has made a bilateral contract with the buyer. Alternatively the aggregator can receive results from clearing of organized markets, for example spot market for electricity, or he can monitor the bids on organized markets with open order books¹. The benefit for an individual consumer or DER owner from trading on organized markets would probably be too low compared to the costs. Currently the market operators have also set rules about the minimum bids and offers to limit their transaction costs. Figure 5 shows electrical and commercial connections between some of the power system participants mentioned.

The aggregator-retailer, in the case when they are the same company, could also need demand response for his own purposes. He may have to monitor his own power balance, i.e., that the

¹ Organized markets where the best bids and offers (asks) are published while trading is on-going.

power purchased and generated match the amount of power sold and consumed within his portfolio of supply (retail) and trading contracts. This balance is calculated in different ways in different countries. Deviation from zero imbalance normally leads to obligation to pay imbalance charges. The aggregator can in some cases dispatch microgenerators or activate EV charging to reduce the imbalance charges and thus create added value for himself and the customers.

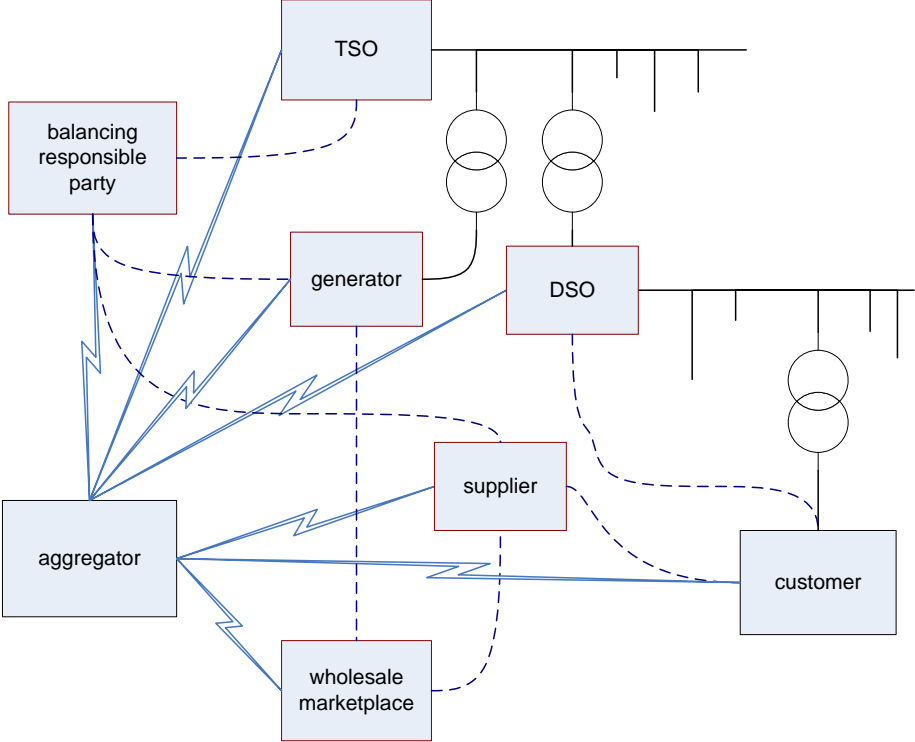

Figure 5: The aggregator, who connects consumers to the electricity market, is shown with both its upstream (buyers of its services) and downstream communication (consumers). The dashed blue lines show some existing information and economic links. Black lines show the electrical connections, blue lines show information and economic links (not in an exhaustive manner)

Microgeneration and EV equipped with smart charging introduce plenty of load and generation flexibility. This is the feedstock on which aggregators live on. Without flexibility there cannot be aggregators. Moreover, the flexibility (ability of loads and generation to respond to various control signals) must be affordable enough so that it can be exploited by power system participants for their needs. Flexibility provided by EV can be estimated to be among the cheapest forms of flexibility provided by small consumers. Thus proliferation of EV with smart charging enable more and bigger aggregators, which leads to more competition and decreasing overhead costs from economies of scale.

When the penetration of microgeneration and new end-use technologies in an aggregator’s or retailer’s portfolio increases, they must be able to forecast the behaviour of these generators and appliances. The retailer must be able to *forecast* microgeneration, power consumption of heat pumps, as well as charging of electric vehicles as a function of time. The aggregator must be able to do this, and in addition he should be able to forecast the responses of these generators and appliances to different control signals (such as price signals). Thus their forecasting tools must have the proper model components for these technologies.

5 Distribution system operators

DSO owns and operates the distribution grid, to which microgeneration and new end-use technologies are connected. Strictly speaking we can say that there are currently no DSO's but distribution network operators (DNO). The difference between DNO and DSO is that DNO operates the network hardware. Voltage control and congestion management, on the other hand, belong to DSO. Ownership and operation of the network are also often separated. In the following we do not make a distinction between DSO and DNO.

DSO is in a central position when integration of microgeneration is discussed. Connecting these generators and appliances to the grid creates various technical and economic consequences to the grid company. On the other hand, the relationship with the DSO is crucial to the consumer because the DSO provides a reliable gateway to the electricity market and guarantees a reliable supply of power when local generation is not used or insufficient to cover local consumption.

Microgeneration can be installed to act as back-up source of power, so that it is run only in case of power outages (cf. diesel back-up generators), or in parallel with the public network so that part of the generated power can be fed into the network. There are also islanded installations which are not connected to the public grid. This task is mostly concerned with installations which can be run in parallel with the public network, and which are also of greatest concern to the DSO.

When penetration of microgeneration and new end-use technologies increases, DSO will have to consider the effects on the following topics:

- power quality,
- network protection,
- occupational safety,
- network planning and construction ,
- metering,
- economic performance,
- customer relations and public image.

Power quality pertains to the voltage level and symmetry across phases as well as the frequency and the magnitude of harmonics of the base frequency. Different pieces of electrical equipment can suffer effects from harmonics in the power system. Voltage issues are probably the main technical concern when increasing DER penetration(EU DEEP 2009). In the presence of local generation the voltage profiles can increase and decrease dynamically along feeders depending on load and generation. Moving away from the primary substation DSO's normally use conductors of decreasing cross-sectional area. This leads to higher input impedance in the network, which in turn leads to variation of voltage due to the export of generated power from microgenerators and distributed storages. The problem is especially relevant to weak networks.

However, a large proportion of distribution networks have sufficient margins and are able to operate satisfactorily in the presence of significant amount of microgeneration (EU DEEP 2009) and EV with smart charging. For example in Finland distribution networks have already been built considering time-of-use tariffs, which may lead to large swings in power

demand when the tariff changes. If the amount of microgeneration (or larger DG units) increases further, various devices and operation techniques are used to maintain the voltage on the distribution lines within the tolerance range. Dynamically changing voltage at the HV-MV substation may provide a partial solution. This however requires that load shapes of different feeders exhibit similar voltage characteristics. However, existing methods of voltage control may prove inefficient when the voltage fluctuates with the output of PV generators (Matsumura et al. 2009). The requirements regarding reliability of distribution systems are becoming increasingly strict, and existing methods of voltage control may require revision. Possibilities include controlling microgeneration and distributed stores according to system needs.

Microgeneration increases the needs for voltage quality monitoring. However, an adequate overall view of the voltage quality can be obtained by permanent measurements at some critical points in the power distribution network. There is no need to install power quality monitoring instruments to a large number of consumers. In the first part of this task some power quality standards were already listed, such as the European standard EN 50160.

An issue related to voltage levels is reactive power compensation. Induction generators consume reactive power, which increases losses in the network. This may need compensation in some cases. The European standard EN 50438 sets limits for the power factor of the microgenerator. The required band is between 0.95 leading and 0.95 lagging, provided the output active power of the micro-generator is above 20 % the rated output power of the unit.

Any power generator which is connected to the public grid needs protective equipment. Their purpose is to prevent disturbances spreading into the public grid when faults occur at the generator and to ensure that the connection of a micro-generator unit will not impair the integrity or degrade the safety of the distribution network. On the other hand prevent disturbances in the grid from damaging the generator. Installation of DG into the grid may also require rethinking of protective equipment in the grid. Adding DG into the distribution network can create a multidirectional power flow situation on parts of the distribution network which were originally designed for unidirectional power flow only. This fundamental change can restrict the operation of the protection system causing false tripping of feeders or blinding of protection (inability of protection relays to issue trip commands in fault situations). In presence of large amount of microgeneration in the distribution grid, excessive fault currents can present a problem. One solution is to add fault current limiters (FCL devices) into the grid (Mäki 2007). These can limit the fault current or interrupt it.

The DSO sets the requirements for the protection of the grid-microgenerator interface. There are also standards such as the European standard EN 50438, which specifies technical requirements for connection and operation of fixed installed micro-generators and their protection devices. It includes both generic requirements and national supplements for several European countries. This standard applies for small microgenerators (≤ 16 A per phase). CENELEC is also working on a standard which concerns requirements for the connection of microgenerators above 16 A per phase (CENELEC 2010). The conclusion can be drawn that a clear and harmonized set of requirements for connection and operation of micro-generators is not yet available. In North America, IEEE 1547-2003 is the relevant grid connection standard for DG up to 10 MVA power. Different European countries have also developed their own technical requirements for connection and operation of microgenerators. However, it will be troublesome for manufacturers if each country implements their own requirements.

In European Union the ENTSO-E proposed requirements for all generators (ENTSO-E 2012) concern also DSO's. This set of rules, once accepted, will overrule national laws and standards. National exceptions are allowed. DSO's are responsible for verifying the compatibility of a microgenerator with the rules. They are also entitled to specify a certain set of requirements but should report to the respective TSO about them.

New end-use technologies can also cause power quality problems. Compressors in heat pumps draw a considerable starting current, causing voltage flicker in the grid. This is most often short-lived and insignificant. However, if the number of heat pumps installed in the same area is large, problems can occur. For example, when power is restored on a feeder line after maintenance work, the simultaneous starting current spikes can trip protection relays in the grid. Motor soft starters in the heat pumps can solve this problem.

Microgeneration should be taken into account by DSO and its subcontractors when working with normally energized parts of the grid. When microgeneration has been installed into the grid, there is a danger of dual supply: it is not enough to isolate the site from the mains side but from all points of supply. Grid technicians should therefore learn the new safety rules.

As the DSO operates as a monopoly, it is normally subject to special regulation. The DSO is often required by law to connect microgeneration, which fulfils the set technical requirements, into the distribution grid. There are often restrictions for the price, which the DSO can charge for connecting the equipment and providing a pathway for the produced electricity. These vary from country to country. For example, there are several connection charging approaches that are currently used in EU. These are generally classed as "shallow", "deep" or a combination of the two. Shallow charging relates to those cases where the consumer pays simply for the cost of the equipment to make the physical connection to the grid network at the chosen connection voltage. The consumer pays no contribution towards any upstream network reinforcements that are needed as a consequence of the generator being connected. Deep charging includes those cases where the consumer pays for all costs associated with the connection, including all network reinforcement costs (Knight et al. 2005). For example in Germany the shallow charging approach is used, in other words, the consumer is not responsible for the costs of upgrading the network due to the installed microgenerator.

In any case, to facilitate the consumer's investment planning, the DSO should give the consumer an estimate of the connection costs. The DSO also has to decide the procedure for connecting new units to the grid and inform the consumer about it. In some countries the "inform and fit" approach, where prior permission from DSO for connecting the generator to the grid is not needed, is allowed for small microgenerators. However, the consumer should inform the DSO afterwards, and the DSO may require contractual modifications of the existing connection agreement with the customer following the installation of the microgenerator.

Microgeneration and heat pumps can have effect on network planning and expansion. EV in large amounts certainly will have an effect. In the European context article 14/7 of the EU Directive 2003/54/EC, which concerns the internal electricity market in EU, requires DSO's to consider DG, together with energy efficiency measures and demand response, as an alternative to network expansion. When controlled in a suitable way, microgeneration, similarly to DR, can reduce peak loads in the network. The ADDRESS project estimated potential reductions in network investments if peak loads could be cut with load shaping (ADDRESS 2012).

Microgeneration and EV introduce new requirements for metering. Since in many cases DSO is the metering responsible party, this should be taken into consideration. For example, there may be a need for smart meters with different registers for generation and consumption. DSO should follow the rules set by local laws, regulators and possibly voluntary associations of network operators when installing smart meters and recovering their costs. Smart meters can also be used to implement simple DR actions at consumer premises if enabled by the DSO. The advantage of such DR implementations is their low cost. There is a separate report about smart meters prepared in this task.

Microgeneration and in some cases heat pumps in the distribution grid reduce the amount of energy supplied by the DSO, leading to reduction of total amount of use-of-system charges. This can lead to the need of defining the use-of-system charges in a different way. They should reflect the cost incurred to provide the network user with the network transport and system service, and on the other hand ensure full recovery of the DSO's total acknowledged costs (Cossent, Gómez & Frías 2008). Naturally the effect of heat pumps on the need of increasing or changing the structure of distribution network tariffs this depends on the current penetration of electric heating in the network. For example in the Finnish context the effect would be small (Tuunanen, Honkapuro & Partanen 2010). If heat pumps replace e.g. gas-fired boilers, the DSO must supply more energy on the annual level. Air-to-air heat pumps cannot decrease the peak load in cold climates due to poor performance in low temperatures.

In which business models, where microgeneration and new end-use technologies play a central role, is DSO involved? While DSO's suffer or benefit from proliferation of microgeneration and new end-use technologies merely because they are connected to the distribution grid, DSO's can also be directly involved in the transactions needed for their operation. DSO can assume two different roles in relation to the services which the new generation and end-use technologies can provide. On the one hand, DSO can act as buyer of these services, and on the other hand, DSO can act as validator of the service provision to guarantee the safe operation of the grid. Validation is a concept presented in the ADDRESS project (Belhomme et al. 2009) and refers to the process where DSO checks the technical feasibility of the service provision from the point of view of the safe operation of the grid. In this role the DSO is not a direct participant in the supply chain of the service.

Figure 6 shows a sequence diagram of such a validation. The aggregator, who needs to provide a service using microgenerators, DR, and EV/V2G, asks for permission for sending incentives to consumers. DSO forecasts and calculates the effects to the grid and based on that sends a full acceptance or a set of curtailment factors as a reply to the aggregator. The aggregator can then send incentive signals to consumers. DSO can also involve the TSO in the validation process when the service deployment could have noticeable effects on the transmission grid.

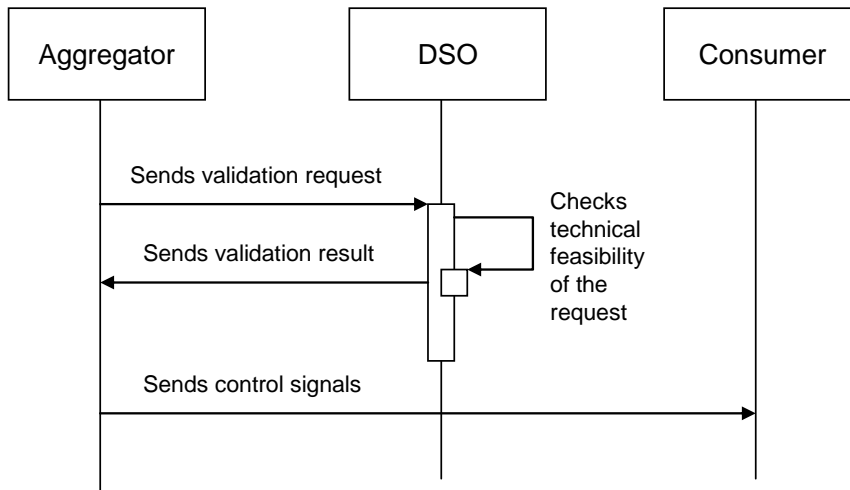

Figure 6: A simplified sequence diagram of the validation process where DSO can allow or disallow dispatching of microgenerators or smart charging of EV, depending on the state of the distribution network.

Various costs of DSO related to the introduction of microgeneration and EV which can respond to system needs must in the end be paid by the consumers. Consumers may protest increasing use-of-system charges and the result can be a deterioration of the relations with consumers. Although as a monopoly provider of an indispensable good this is not as serious for DSO as it would be for a competitive actor, it is still an effect to consider.

6 Transmission system operators

Microgeneration and new end-use technologies present both challenges and opportunities for TSO's. On the one hand, some microgeneration technologies such as PV and small wind turbines can disturb power balance by producing unpredictable power surges. There are technical challenges, which may occur at different time scales from split-second to more pronounced inter-area oscillations (0.1 to 1.0 Hz) (NERC 2010). It is likely that the effects of new technology on system stability will reduce their penetration unless new methods and tools are developed, e.g. for frequency and voltage control. On the other hand, some microgeneration and EV technologies can even help mitigate problems in the power system.

Transmission system operators manage the following responsibilities for operating interconnected power transmission systems:

- system management,
- system balancing / frequency stability,
- voltage stability,
- system restoration after a disturbance.

TSOs' responsibility is to ensure system security with a high level of reliability and quality. As part of system management, TSO's need to prepare security analysis for present and forecasted situations. They need to forecast congestions and prepare remedial actions. For this purpose they need to know (ENTSO-E 2012)

- the availability of generating units to produce power and to provide ancillary services (actual and forecasted),
- their technical characteristics and capabilities and to be informed of temporary limitations (e.g. reactive power supply limitations, inability to change active power) and
- the actual active and reactive power output from the generating units.

Currently this does not fully apply to microgenerators because their number and total effect on the power system is still small. TSO does not need to follow the power output of every microgenerator. However, if an aggregated group of microgenerators can respond to power output request, then they may be able to provide ancillary services. These are services which can ensure the secure operation of power systems, most notably power reserves, voltage and reactive control and black start (ACER 2011). Currently microgeneration and DS has little contribution to the ancillary services. For example, in EU member states their contribution was very low as of 2008 (Cossent, Gómez & Frías 2008). Also, the contribution of DG in general was mostly limited to reactive power control and energy balancing. The capability of DG to contribute to congestion management to save network investments was hardly recognized in EU.

TSO's need ancillary services in maintaining the real-time balance between power generation and load demand (including grid losses). The necessary control and balancing power is provided by reserves (frequency containment and restoration reserves and replacement reserves), which may include power generation units and controllable loads. It is necessary that these reserves are able to increase or decrease their production or consumption quickly and that margins are available in both directions. Again, if an aggregated group of microgenerators or distributed storages such as EV can respond to power output request, then they may be able to participate in reserves. For individual microgenerators this is currently not possible because of the high transaction costs involved. Indeed, if the penetration of microgenerators and EV reaches a high level, they have to participate to system control and provision of reserves similarly to conventional power stations (EU DEEP 2009).

Another problem in implementing DR especially for heat pumps is that the current products cannot normally receive an automated control signal, such as temperature setpoint. Thus implementing DR is more complicated for heat pumps than for electric heating.

TSO's often use the balancing market (regulating power market, balancing mechanism) to maintaining the real-time balance between power generation and demand. This can be understood as a grey area between electricity markets and ancillary services. In some countries, e.g. Germany and the Netherlands, DG can participate balancing markets through aggregators (Cossent, Gómez & Frías 2008). This is possible also in Finland, as long as the total portfolio offered to BM is large enough and near real-time measurements are available. Different implementations of the balancing market exist in different countries in terms of pricing, timing and requirements for the participants. For example in the Netherlands and Finland, a response time of no more than 15 min is required from the participating resources, whereas in Great Britain the requirement is even more strict. Minimum power limits have also been set in different countries. The requirements naturally affect the possibilities of aggregated microgeneration and EV to participate in the balancing market.

The effects of microgeneration on the balancing market depend on several things, most important of which are the types of microgenerators and the way they are controlled. The buildings and existing heating systems in which they are installed also play a role because

they determine the heat and power demand and heat storage capacity. As was noted in chapter 2, μ -CHP can be operated according to the heat demand, local power demand, or to minimize total heating and electricity costs. The power supplier can also be given the authority to control μ -CHP operation directly or by power price signals. In Figure 7 the effect of large amount of microgeneration on especially the Dutch balancing market has been evaluated. The assumption in this study was that 30 % of all consumer households have installed a microgenerator with 1 kW_e capacity. As expected, PV microgenerators (without energy storage) have a negative effect because of the unpredictability of power generation. μ -CHP had a positive effect, especially when operated by the power supplier.

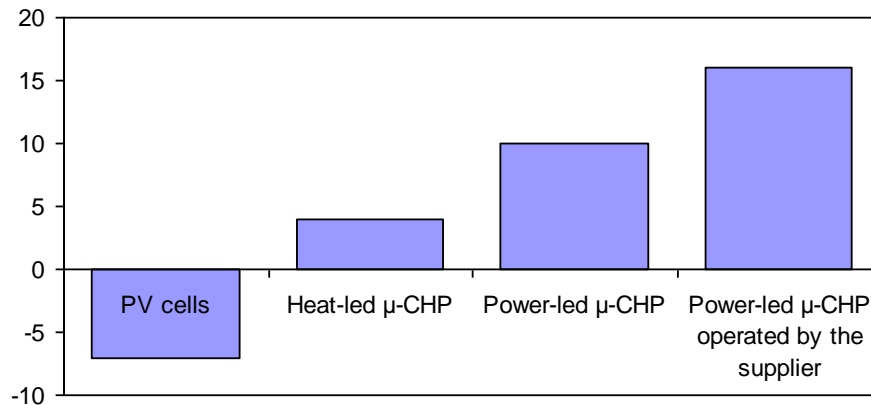

Figure 7: Qualitative effect of large amount of different types of microgeneration on the Dutch balancing market (De Vries, Van der Veen 2009). Positive values mean positive effect in terms of network stability, accuracy of production and consumption schedules, liquidity in the balancing market and five other criteria.

A well-known fact is that microgenerators have reduce frequency stability of the grid. Microgenerators, which are often connected to the grid through power-electronic-based inverters, differ significantly from the conventional generator types, particularly in terms of their impact on electromechanical stability. The rotational inertia of synchronous machines plays a significant role in stabilizing the frequency during a transient load and generation imbalance. For microgenerators the inertia is usually much smaller. However, the rotational inertia can be emulated in some types of microgenerators using a suitable control system.

For TSO's to be able to maintain the voltage in acceptable ranges throughout the network and to prevent the transmission systems from voltage collapses, the generation units have to be able to provide reactive power to the network within a definite range. Shortage of reactive power can lead to unacceptably low voltage levels and finally to a voltage collapse of the system. If microgeneration replaces a large share of larger synchronous generators, there could be a lack of reactive power capacity. The impact of DG on TSO reactive power market will be driven by many different variables, though and requires further studies (Djapic et al. 2006).

Technical requirements for grid connection of microgenerators are also of concern to TSO's. Although these generators are connected to distribution networks, in large numbers they can also affect the transmission grid. In European Union common rules are being prepared. In 2010 the European Commission asked the association of European energy regulators (ACER) to start preparing a common European network code. In 2011 ACER published framework guidelines for preparing the network code (ACER 2011). The practical work is being carried

out by the association of European TSO's, ENTSO-E. In Autumn 2012 ENTSO-E submitted the final draft to ACER. ACER will further submit it to a comitology committee chaired by the European Commission. The network code will come into force earliest in 2013.

This network code concerns both microgenerators connected to distribution grid as well as conventional power stations connected to transmission grid (ENTSO-E 2012). Generators have been divided into four classes A–D according to power output. Class A starts from 400 W power. Thus the network code applies to almost all microgenerators. Special attention has been paid on cases when generators should remain connected to the system. In case of contingencies microgenerators, when their penetration is high, should remain connected to the system to avoid further deterioration of the system's state. A driver for this rule has been the disturbances in the central European electricity grid in 2006 and increasing penetration of microgeneration. The network code developed by ENTSO-E specifies required behavior in case of frequency and voltage variations (including low voltage ride through requirement) but the requirements are not uniform across Europe.

To achieve the integration of large amounts of microgeneration, research still needs to be done. R&D in transmission grids plays a crucial role in achieving the goal of integrating significant amounts of renewable energy sources (including microgeneration) while also maintaining the security of supply. It is also necessary for integrating electricity markets across countries. Both are concerns for TSO's. Thus, TSO's research activities are not only driven by microgeneration or electric vehicles but they are one driver. On the European level the following topics will require further studies (ENTSO-E 2010):

- Novel approaches to develop a pan-European grid;
- Power technology: affordable new technology components that can significantly improve the operations of the interconnected transmission systems, and flexible utilization of smart grids applications for services and to balance the transmission grid;
- Network management and control: critical building blocks to operate the interconnected transmission system in real time and reliably;
- Market rules: designing new markets for balancing and ancillary services at European level and simulating markets with DER.

Some of these topics are also valid for other regions except EU.

New power technology can help to reduce the extra costs that will come from the variability of some types of microgeneration as well as large-scale wind power. Technologies such as flexible AC transmission system devices (FACTS, including various types of compensators such as unified power flow controllers), wide area monitoring (WAMS), control and protection systems, and energy storages will be of interest. Network management includes e.g. more robust and accurate assessment of the security limits. This could be done by developing new simulation techniques taking into account not only the TSO's own network but also neighbouring networks. The topic of market rules include also proposing market mechanisms to ensure a sufficient capacity reserve. Modeling and simulations are needed in all the topics. Models should be developed to find out the effects of microgeneration and new end use technologies as such but also of the dynamics of WAMS-enabled monitoring and control.

In which business models, where microgeneration and new end-use technologies play a central role, is TSO involved? While TSO's suffer or benefit from proliferation of microgeneration and new end-use technologies merely because they are connected to the subgrids of the transmission network, TSO's can also be directly involved in the transactions needed for their operation. According to the ADDRESS project, TSO could also validate aggregator's dispatch schedules, which could have a significant effect on the transmission network. In other words, according to the ADDRESS concept (Belhomme et al. 2009), the TSO first has to give acceptance to concerted control actions of microgenerators and smart loads. As mentioned TSO's can buy ancillary services from microgenerators via aggregators. Aggregators are important because they make a large number of DER visible to the TSO at an acceptable cost.

7 Power exchanges

Power exchanges facilitate power trading by maintaining organized markets for power. They can provide a reference price for the sales and purchases between microgenerators and aggregators. Retailers and aggregators trade on organized power markets. Power exchanges normally maintain lower power limits for bids as well as participation fees, which prevent individual microgenerators from directly participating the organized markets. However, it is possible that these will change in the future.

Partly due to increase of renewable power generation, European Council has concluded that the EU needs an interconnected and integrated internal energy market. Thus in Europe power exchanges are currently in an integration process. This involves mergers and acquisitions among existing power exchanges, growth into new areas, and market coupling initiatives. The "Price coupling of regions" project aims to implement price coupling in the day-ahead market in central western Europe, Iberian peninsula, Great Britain and Nordic countries. Nord Pool Spot, EPEX, GME, OMEL, Belpex and APX-ENDEX are participating the project. The benefit can be better load and generation distribution across Europe and better network utilization.

As part of the price coupling, TSO's also need to calculate the transmission capacities between day-ahead market areas (see Figure 8). The price coupling process has been described in an ENTSO-E Network Code on Capacity Allocation and Congestion Management, which is under preparation at the time of writing and should be approved by ENTSO-E in September 2012.

Power exchanges should also think about developing products for microgenerators and demand response. For example Nordpool has launched the flexible hour bid product in its day-ahead market (Elsport), which is suitable for e.g. DR. The seller can offer to sell power on the hour of the highest price of the day, if the price exceeds the ask price (energy price) set by the seller. Thus the time of the offer is not fixed. A further idea could be to include also the estimated payback peak into this flexible bid.

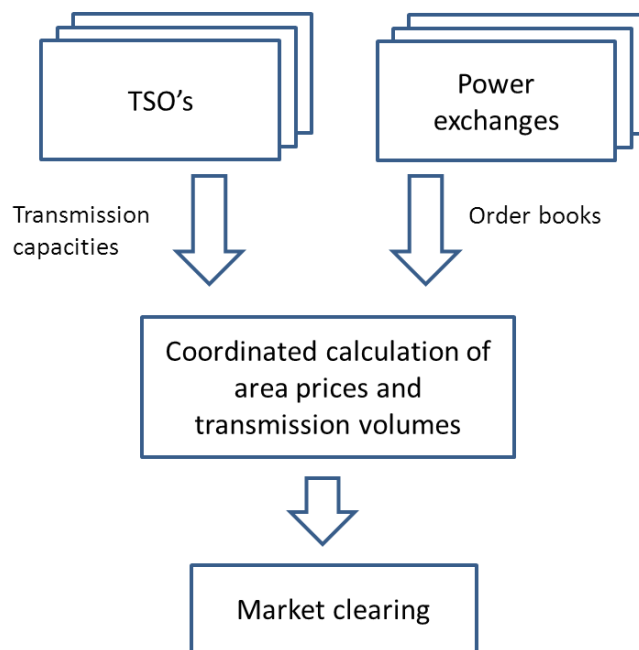

Figure 8: The price coupling process of power exchanges requires that TSO's have a common grid model, which can be used to calculate transmission capacities.

8 Regulators and energy agencies

Regulators supervise the pricing of electricity transmission, distribution and other network services. They also promote efficient competition in the electricity trade, by intervening in the terms and prices of the network services that are considered to restrict competition. Also, they take part in the preparation of new regulations. They follow the development of the electricity sector internationally and coordinate regulation harmonization efforts in their own country. Regulators often administer different support schemes designed for renewable generation and micro-CHP. They sometimes reduce the administrative burden by setting a lower power limit to the installations which are eligible for support. This is the case for example for the feed-in tariffs in Finland. Naturally, this creates a problem for microgeneration.

Energy agencies promote efficient and sustainable use of energy by providing information and influencing attitudes and consumer habits. They can have an important role in informing end-users about the costs and benefits of microgeneration, heat pumps and EV, as well as about the available subsidies, installation procedures, etc. These roles can also be assumed by national associations, which promote certain technologies, such as heat pumps, PV or small wind generators.

9 Governments and support schemes

Governments make decisions on support and taxation schemes based on estimates on how they benefit the industry, fiscal goals and society as a whole. Support schemes can be seen as differentiation in how competing technologies are treated. Reasons behind support schemes

include mitigation of greenhouse gas emissions, introduction of new sustainable technology with improved energy efficiency, and support for local industry.

As noted in the Introduction, there are stakeholders which do not take part in the business but who are otherwise involved, and society itself is one of them. We already concluded that support schemes are often important, maybe even crucial, for investors in microgeneration or new end-use technologies. For support schemes society is the main stakeholder, as the support schemes exists because society has a desired behavior in mind and wants to guide the business accordingly. Support schemes enable the proliferation of energy producing technologies before they reach grid parity. For example, no one would be interested in photovoltaics at the current cost level without subsidies, except in off-grid applications.

Society has several other tools to use than just FITs or similar support schemes. By inserting restrictions or regulations the power system (and thus business models) is guided towards the desired direction and can be seen as support to some stakeholders and/or weaken the position of other stakeholders.

Stakeholders are deeply influenced by the different fiscal support –or hindrance- systems that exist. Taxation and tax exemptions have traditionally been important drivers, but nowadays more and more new influencing forms arise and are in use, for example feed-in tariffs and green certificates. Below we list some types of support schemes. They can be compared based on e.g. the following criteria (Kildegaard 2008):

- quantity of energy production stimulated as a direct result of the policy;
- total cost of the energy produced (including the incentive cost);
- the degree to which investment and ownership in the new industry is controlled by the local population and contributes to local development objectives;
- how the domestic manufacturing industry has been stimulated to supply power generation equipment.

Different support schemes are already established in many countries for different microgeneration technologies. These have been mentioned in the technology report country annexes. Support schemes could also be necessary for small customer DR.

9.1 Feed-in tariffs

Feed-in tariffs (FIT) are in use to support new renewable or energy efficient power production. The owner/user of the new production facility is supported. Whoever pays the producer according to the FIT, he has to be remunerated. It can be all tax payers, all electricity users, or all users except energy intensive industry.

One big variable with FIT schemes is pathway of the generated power on the electricity market. If it is no party is obliged to purchase the power, then it is up to the producer to sell it to the market (and incur the resulting imbalance costs). If the system operator is obligated to purchase the power, as a neutral party he will transfer it to the market as such and take care of the imbalances.

As FIT's are not very cost-effective, more and more often there are different tariffs for different technologies, e.g. a wind power plant might get a lower support than a PV etc. The tariffs can also vary according to the strength of the site resource, such as windiness of the area. This is society's way to dominate over the market choices.

Power which is used on-site may have a different feed-in tariff than power which is fed into the grid. PV in Germany is a good example. Households get a high feed-in tariff for PV that is fed to the grid, but they get a FIT for PV consumed at site also. Naturally this requires that the generation is metered separately. Although the tariff is lower, together with the avoided costs of purchased electricity it is more profitable to the household.

9.2 Tradable green certificates

Tradable green certificates (TGC) for renewable energy production can be used by governments to dictate that a certain portion of electricity consumption must be renewable energy. For example, retailers can be required to supply a certain percentage of their electricity from renewable sources. They can demonstrate compliance to this rule by presenting green certificates, which they can buy from certificate markets. Producers on the other hand are credited green certificates for every MWh of renewable energy which they produce and act as sellers on the TGC market.

TGC are usually considered more market-oriented than FIT's (Kildegaard 2008). They usually let the market decide on what to do to achieve the certificate target, which gives more cost-effective solutions an upper hand. Whereas FITs might lead to extraordinary fast results, such as the introduction of PV in Spain or Germany the last years, it is usually because they are so cost-inefficient that the profits for the stakeholder are overwhelming. Green certificates are in use for example in Sweden, where they have performed well despite their slow start.

9.3 Taxes and tax rebates

Taxes are not only about gathering fiscal revenues to the state or municipality, they are also used to guide the market into the desired direction. Set up high taxes on fuels sold to end-users and they might not be so eager to invest in micro-CHP, but if the taxes are put more heavily on electricity purchases, then the shoe is on the other foot. Different taxes for different producers/fuels/production forms/investments all affect individual choices. If the end-user has to declare VAT or pay some other cumbersome tax for his production to the grid, then it is a hindrance.

Tax rebates for EV's is a good example of how the end-user can be manipulated. Instead of FIT's, renewable power production could be given tax rebates or even negative taxes. The EU, for example, has set up a system where large producers of electricity or heat (boiler capacity > 20 MW) have to have emission rights, which have to be bought. This gives an advantage to producers with smaller emissions and to small producers who are exempt from the emissions trade.

9.4 Investment support

In many case consumers are offered direct investment support if they install PV panels, micro-CHP, heat pumps, or other forms of microgeneration or new end-use technologies. To some extent, investment subsidies may raise equipment sales prices.

9.5 Other regulations

The regulations can be supportive, for example that power production from renewables are to have grid priority. Net metering is another example of regulations. It means that the end-user can also inject power into the grid and benefit from it economically. Depending on if the net

metering concerns only the network or also the retailer, they are affected. End-users are beneficiaries, as they can reduce more of their purchases through their own on-site production. Net metering on a large scale can lead to income losses for DSO's, as the energy supplied by the distribution grid will decrease, and to increased imbalance costs for retailers. DSO's may have to alter their consumption-weighted tariffs in that case.

An example is that the existing regulation scheme for DSO monopolies in Finland does not consider investments in storage and local generation as network investments and the DSOs are not allowed to own DG. Thus the network operators cannot use DG and storage in situations where they are technically the most cost efficient means to remove network capacity bottlenecks.

10 Summary

There are many different parties which are affected by the introduction of microgeneration, heat pumps and EV. Most important are end-users, DSO's, TSO's, retailers, aggregators and manufacturers. Other parties include standardization bodies, installers, market operators, regulators and governments. The stakeholders need to consider many aspects of the new technologies, which are specific to each type of stakeholder. These include installation, legislation and permissions, communication, control, DR capability, power quality, network stability, etc.

For consumers savings and simplicity are often the most important things. Thus subsidy and installation procedures should be simple and uniform. DSO's should require only an installation report of a unit, which has been compliance tested according to certain set of requirements, from a qualified installer. DSO's should further develop tariffs to secure their income when the number of microgenerators and heat pumps increase. To implement DR with the new technologies, manufacturers should add machine-to-machine communication ability using widespread standards. Regulators should develop rules which allow microgenerators to sell their excess power to the grid at a fair price. DSO's and TSO's should also cooperate internationally to harmonize the technical requirements for connection and operation of microgenerators as far as possible.

In each case the costs and benefits to each stakeholder depend on the details of technologies and their methods of control, as well as on the details of contracts between stakeholders. For example, microgeneration may in some cases benefit DSO in the form of reduced peak load but the negative effect on revenue may be much larger. Thus the specific tariff applied has a crucial effect. Similarly, the financial incentives applied between an aggregator and consumer have a crucial effect on the benefits and behaviour of both parties. Also electricity market rules, regulations and subsidies have a large effect. It is important that in each case the key parties involved should find rules, tariffs and incentives, which allow all stakeholders to benefit, or at least not suffer, from the introduction of the new technologies. Otherwise it will be difficult to form successful business models on voluntary basis.

The appendices provide some examples of stakeholder involvement from four different countries. Appendix 1 introduces some elements of business models related to EV and smart meters in Spain. Appendix 2 introduces business models for EV charging in Austria. Appendix 3 contains a more detailed analysis of different power-based tariffs from the point

of view of the DSO in Finland. Appendix 4 contains an analysis of different stakeholders involved in EV, PV and smart meters in France.

References

- ACER 2011, *Framework Guidelines On Electricity Grid Connections*, the European Agency for the Cooperation of Energy Regulators.
- Akkermans, H. & Gordijn, J. 2006, "Business models for distributed generation in a liberalized market environment", *Electric Power Systems Research*, vol. 77, no. 9, pp. 1178-1188.
- Belhomme, R., Sebastian, M., Diop, A., Entem, M., Bouffard, F., Valtorta, G., De Simone, A., Cerero, R., Yuen, C., Kärkkäinen, S., Fritz, W. & Ikäheimo, J. 2009, *Deliverable D1.1 - Conceptual architecture including description of: participants, signals exchanged, markets and market interactions, overall expected system functional behaviour – Core document.*, ADDRESS.
- CENELEC 2010, *CLC/FprTS 50549-1:2011: Requirements for the connection of generators above 16 A per phase to the LV distribution system or to the MV distribution system*.
- Cossent, R., Gómez, T. & Frías, P. 2008, "Towards a future with large penetration of distributed generation: Is the current regulation of electricity distribution ready? Regulatory recommendations under a European perspective", *Energy Policy*, vol. 37, no. 3, pp. 1145-1155.
- CRC Research , *A Microgeneration Strategy for Canada* [Homepage of CRC Research], [Online]. Available: <http://www.crcresearch.org/case-studies/case-studies-sustainable-infrastructure/energy/a-microgeneration-strategy-canada-part-1> [2011, 3/15].
- De Vries, L.J. & Van der Veen, R.A.C. 2009, "The impact of microgeneration upon the Dutch balancing market", *Energy Policy*, vol. 37, no. 7, pp. 2788-2797.
- Djapic, P., Jenkins, N., Lopes, J.A.P., Hatziargyriou, N. & Mutale, J. 2006, "Integrating distributed generation into electric power systems: A review of drivers, challenges and opportunities", *Electric Power Systems Research*, vol. 77, no. 9, pp. 1189-1203.
- ENTSO-E 2012, *ENTSO-E Draft Network Code for Requirements for Grid Connection applicable to all Generators*, Working draft edn, ENTSO-E.
- ENTSO-E 2010, *Research and Development Plan*, ENTSO-E.
- Environment Canada 2006, , *Evaluation of the One-Tonne Challenge Program* [Homepage of Environment Canada], [Online]. Available: <http://www.ec.gc.ca/ae-ve/default.asp?lang=En&n=E0530F2A-1&offset=17&toc=show> [2011, 3/15].
- EU DEEP 2009, *Results - Integrating Distributed Energy Resources into today's electrical system*, ExpandDER alliance. <http://www.eudeep.com>.
- Kildegaard, A. 2008, "Green certificate markets, the risk of over-investment, and the role of long-term contracts", *Energy Policy*, vol. 38, no. 7, pp. 3413.

- Knight, R.C., Montez, J.P., Knecht, F. & Bouquet, T. 2005, *Distributed generation connection charging within the European Union: review of current practices, future options and European policy recommendations*, ELEP - European electricity production deliverable 2.1.
- Leach, M. & Hawkes, A. 2007, "Cost-effective operating strategy for residential micro-combined heat and power", *Energy*, vol. 32, no. 5, pp. 711-723.
- Mäki, K. 2007, *Novel Methods for Assessing the Protection Impacts of Distributed Generation in Distribution Network Planning*, Tampere University of Technology.
- Matsumura, T., Iioka, D., Izuhara, N., Yokomizu, Y. & Sakakibara, K. 2009, "Distribution voltage rise at dense photovoltaic generation area and its suppression by SVC", *Electrical Engineering in Japan*, vol. 166, no. 2, pp. 47-53.
- Olson, A., Jones, R. 2012, *Chasing Grid Parity: Understanding the Dynamic Value of Renewable Energy*. The Electricity Journal, vol 25, p. 17.
- NERC 2010, *Reliability Considerations of Integration of Smart Grid*, NERC, North American Electric Reliability Corporation.
- Norwood, Z., Lipman, T., Stadler, M. & Marnay, C. 2010, "Assesment of combined heat and power system "premium power" applications in California", *International Journal of Distributed Energy Resources*, vol. 6, no. 2, pp. 131.
- Similä, L. 2009, *Energy Visions 2050*, Edita Publishing Ltd. ISBN 978-951-37-5595-9.
- Tuunanen, J., Honkapuro, S. & Partanen, J. 2010, "Energy efficiency from the Perspective of Electricity Distribution Business", *NORDAC 2010*Aalborg, Denmark, 6-7 September 2010.

Appendix 1 Spanish business cases for EV and smart meters

Asier Moltó-Llovet

A 1.1 Electric vehicles business cases

In the process for the integration of distributed resources within the grid there are different levels of maturity depending on the technology. Electric vehicle has been a very important field of activity in the regulatory framework and therefore the stakeholders positioning is more mature than in other technologies like distributed storage for instance.

In fact in Spain it is not possible the demand aggregation and therefore the regulatory framework has to evolve to enable the new market role of aggregation.

However in the EV this evolution in the regulatory framework have been done and the Electricity Sector Act (ley 54/1997) has been modified in order to include a new actor, the “Load manager” (therefore the regulatory framework for the aggregator has been created), and a consumer with the capability to resell energy for charging EVs, and a new activity, the “Charging services”.

This law consider load manager as end users enabled to resell energy only for charging EV and for storage for a better management of the electric system, this function cannot be done for any regulated company. On the other hand the “charging services” are defined as the provision of energy services to EV or storage units enabling the integration of renewal energies. In addition, this new player has to implement DSM programs and to communicate with control center form grid operators. This is a very promising point in Spain because it should drive many of the future developments is the role of “aggregator”.

In the case of EV, an aggregator of electric vehicles is the commercial middleman between a collection of PEVs and electric system agents (TSO, DSO, retailers). From the TSO perspective, the aggregator is seen as a large source of generation or load, which can provide ancillary services and can also participate in the electricity market with supply and demand energy bids, as indicates in the following market model.

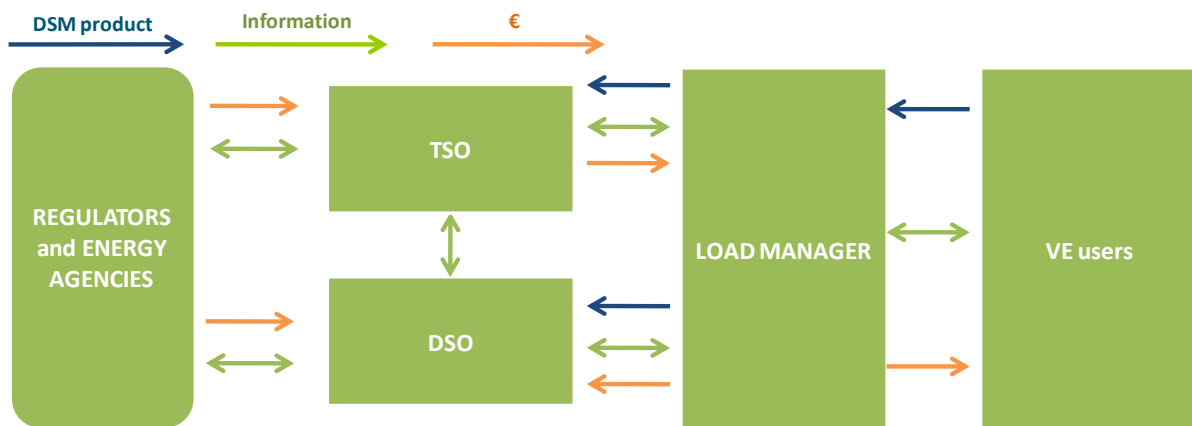

Figure A-1: Market model for Spanish DSM provided by EV users

Currently there are 3 new stakeholders that are starting their activities as load manager in Spain, one created by a Regional Energy Agency and the other two created by the retailers of big utility companies.



Listado de Gestores de Cargas

Nº ORDEN	RAZÓN SOCIAL	DOMICILIO SOCIAL	POBLACIÓN	PROVINCIA	C.P.	TÉLEFONO	FECHA INICIO OC	AMBITO ACTUACIÓN	INSTALACIÓN	DIRECCIÓN	POBLACIÓN	PROVINCIA	CC.AA.
R4-0001	IBIL GESTOR DE CARGA DE VEHICULO ELÉCTRICO, S.A.	C/ GRAN VÍA, 45 1ª PLANTA, DPTO. 108	BILBAO	BIZKAIA	48011	94 405 20 00	16/06/2011	ESPAÑA	IRIAN VIA 45, SOTANO 5	BILBAO	BIZKAIA	PAIS VASCO	
									PARQUE EMPRESARIAL BARRABARRS EDIFICIO A-2	LEICA	BIZKAIA	PAIS VASCO	
									PLAZA DE INDALTXU 2 48010	BILBAO	BIZKAIA	PAIS VASCO	
									AVENIDA DE LA RIBERA 1	BARAKALDO	BIZKAIA	PAIS VASCO	
									CARRITERA BILBAO-SALDAKKAO 30	BILBAO	BIZKAIA	PAIS VASCO	
									PLAZA IRUN SIN	DONOSTIA	GIPUZKOA	PAIS VASCO	
									BOULEVARD SALBURUA SIN	VITORIA-GASTEIZ	ALAVA	PAIS VASCO	
									PARQUE TECNOLÓGICO, 210	ZAMUDIO	BIZKAIA	PAIS VASCO	
R4-0002	E.ON ENERGÍA, S.L.	C/ MEDIO, 12	SANTANDER	CANTABRIA	39009	91 418 44 00	08/08/2011	SANTANDER	AUTONOMIA 8, 20870	ELGOIBAR	GIPUZKOA	PAIS VASCO	
									ALBITXURI INDUSTRIALINEA 2, 20870 (C/ INOJEZ KARKIZANO)	ELGOIBAR	GIPUZKOA	PAIS VASCO	
									PASEO PEREDA 30	SANTANDER	CANTABRIA	CANTABRIA	
									CALLE REAL CONSULADO	SANTANDER	CANTABRIA	CANTABRIA	
R4-0003	GAS NATURAL SERVICIOS SDG, S.A.	PLAZA DEL GAS, 1	BARCELONA	BARCELONA	08009	93 402 53 01	24/11/2011	ESPAÑA	AVDA GARCIA LAGO	SANTANDER	CANTABRIA	CANTABRIA	
									CALLE LUCIANO MALUMBRES	SANTANDER	CANTABRIA	CANTABRIA	
									CALLE DE LA PLAZA, 4	A CORUÑA	A CORUÑA	GALICIA	
									CARRITERA CIRCUNVALACIÓN, 1-15	A CORUÑA	A CORUÑA	GALICIA	
									C/ ENRIQUE MARINAS ROMERO PERIDI, 0	A CORUÑA	A CORUÑA	GALICIA	
									RUA DE LA TORRE, 90	A CORUÑA	A CORUÑA	GALICIA	
									AVDA DEL ALCALDE ALFONSO MOLINA	A CORUÑA	A CORUÑA	GALICIA	
									C/ GALILEO GALILEI	A CORUÑA	A CORUÑA	GALICIA	
COSTA DE PALLOZA 5	A CORUÑA	A CORUÑA	GALICIA										

Figure A-2: Examples of load managers in Spain.

A 1.2 Smart Meters business cases

In Spain there is a National Plan for Meters Substitution which involved the obligation for distribution companies to change 26 millions of meters in the residential sector in Spain for 2018. Figure A-3 shows the percentage of additional (not cumulative) metering points to be installed by 2014, 2016 and 2018.

Consumers can choose between buying the meter or pay a rent (most used option) which implies to pay around 15 % more each month for the smart meter rent since the moment that they have a new meter.

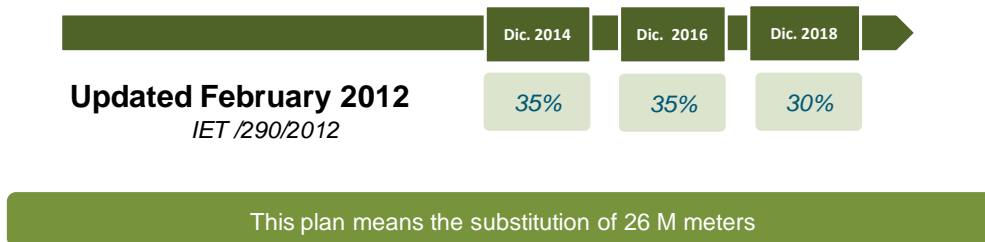

Figure A-3: Spanish Smart Meters Substitution Plan

In Spain there are two types of smart meters that are being installed, the meters under the alliance METERS&MORE (Same as in Italy and in the future it will 40% of Spanish market)

and meter the alliance PRIME (same as France and Portugal and in the future it will be 60% of Spanish market)

In this technology, there is not the possibility of the aggregation, being the distribution companies responsible of the installation.

A lack of regulatory definition is needed in order to define what services are going to be provided using this smart meters and how distributors are going to give information to the retailers about end user data. In fact, this is not only a Spanish debate but also European and Spanish companies are helping to define the European model of interaction between stakeholders regarding smart meters.

Appendix 2 Stakeholders for integration of electric vehicles into the Austrian energy system

Maximilian Kloess

Wolfgang Prügler

Rusbeh Rezania

A 2.1 Introduction

A high penetration of EVs (electric vehicles) in an energy system leads to an interaction between two different businesses: the energy and transport sector. A successful integration will be affected by driving patterns and the distribution of charging points. The EVs will add new loads to the power system with a potential for offering storage capacity through V2G (vehicle to grid) and G2V (grid to vehicle) applications. Also a large number of EVs connecting in one area might cause negative influences on local grid (low and medium voltage grid) restrictions (transformers, line overloading and voltage stability issues). In this conjunction the EVs, with appropriate charging and discharging strategies, could be used for providing different power system services such as:

1. Providing grid services for a distributed system operator (DSO) such as load leveling and PV-based charging and
2. Participating in alternatively designed energy and control energy markets.

The high penetration of renewable energy sources particularly PV in low voltage grids will result in high power production during sunny days. To deal with this problem, the DSO has generally two solutions. One is the grid reinforcement by using transformers and cables tolerating higher capacities. An introduction of devices, which store the energy during high generation periods, could be the second option. The mentioned second solution can also be realized with PV related charging strategies of storages.

The EVs could be used for power system services as well. They could provide ancillary services which are contracted by Transmission System Operators (TSOs). The services are provided by contracted tertiary-, secondary and primary reserves. To ensure the mentioned reserves different control energy markets have been settled and organized by a balance group coordinator and TSO in the liberalized Austrian electricity market.

Thus, this report focuses on the integration of electric vehicles into the Austrian energy system. The aim is the description of framework conditions for a high penetration of EVs and their integration and encouragement for Demand-Side-Management (DSM) applications. In the context of their usage for DSM-application, the interactions between the needed actual und new stakeholders in electricity sector builds up the main part of the report.

The report starts with an overview about the EV penetration in Austrian energy system based on different influencing factors (fossil fuel prices and policies with adaption of different car taxes, registration taxes and ...) and a general description of liberalized Austrian electricity market. The discussion of different EV business models, resulting use cases and the involved market Agents based on various charging station distributions takes place in the fourth and

fifth part of this report. A qualitative comparison between the use cases is provided in Chapter 5. The summary and corresponding conclusion including open questions close the report.

A.2.2 Penetration of EVs in Austria

To estimate future fleet penetration of plug in hybrid (PHEVs) and battery electric vehicles (BEVs) in Austria the ELEKTRA scenario model was used. This model was developed to analyze the impact of economic and politic framework conditions on passenger car transport in terms of energy demand, energy carriers and greenhouse gas emissions. A schematic overview of the mode is given in .

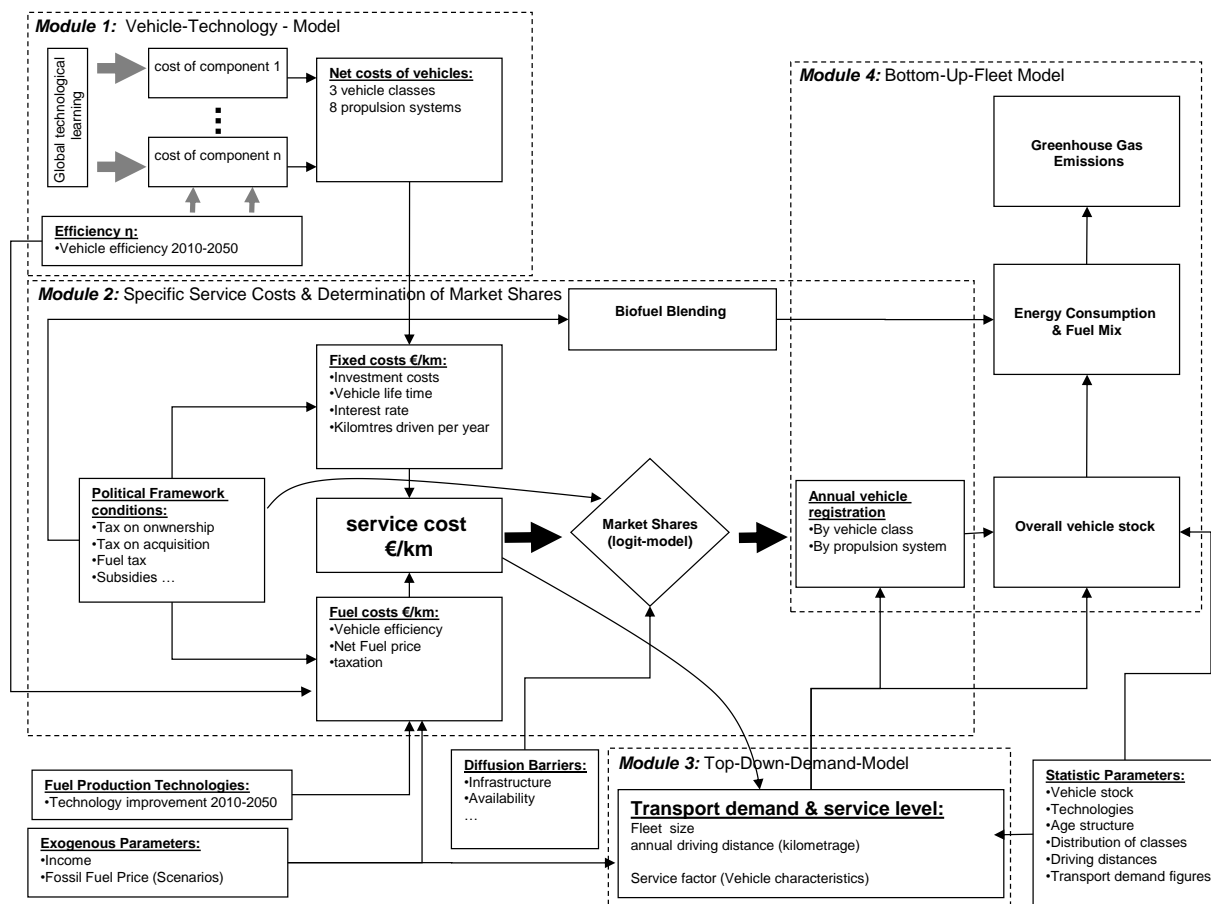

Figure A-4: Scheme of the ELEKTRA model.

The model combines top down and bottom-up modeling approaches and consists of four main modules:

- Module 1: The first module is the vehicle technology model where different vehicle powertrain options are modeled bottom-up to capture the influence of technological progress on their costs.
- Module 2: The second module derives market shares of technologies based on their specific service costs considering different levels of willingness to pay. The heterogeneity in consumer preferences is modeled using a logit-model approach with specific service costs as the main parameter. The technology-specific diffusion

barriers that arise from limitations in performance characteristics or lack of availability etc. are modeled by predefined constraints of maximal growth in market share of each technology.

- Module 3: The third module includes the top down models that capture the influence of income, fuel prices and fixed cost on the demand for passenger car transport and transport service level.
- Module 4: The fourth module is a bottom-up fleet model of the Austrian passenger car fleet. The fleet is modeled in detail considering age structure, user categories and main specifications of the cars (e.g. engine power, curb weight, propulsion technology, specific fuel consumption, greenhouse gas emissions etc.). The settings are based on a data pool including detailed information about the fleet today and time series of its historic development between 1980 and 2008. A detailed description of the model can be found in [1] and [2].

The model can simulate effects of technological development and changing political and economic framework conditions on the passenger car fleet. The impact of changing fossil fuel prices and different fuel- and vehicle taxation schemes on the passenger car fleet in terms of fleet size, vehicle specifications, efficiency, vehicle use and diffusion of technologies can be analyzed through scenarios for the time frame 2010-2050.

Figure A-5 shows a fleet development scenario for the time frame 2010-2050. In this particular case ambitious policy measures implemented up to 2020 are assumed. Together with a reduction of battery costs due to learning effects, these measures lead to a considerable diffusion of PHEVs and BEVs up to 2050. The main policy instruments, assumed in this scenario are higher fuel taxes and higher taxes on acquisition of cars with low efficiency. Fuel tax on gasoline and diesel is assumed to be increased stepwise between 2010 and 2020 which makes electrified cars more competitive. For tax on acquisition a feebate system is assumed that gives more financial incentives to buy fuel efficient and hence electrified cars.

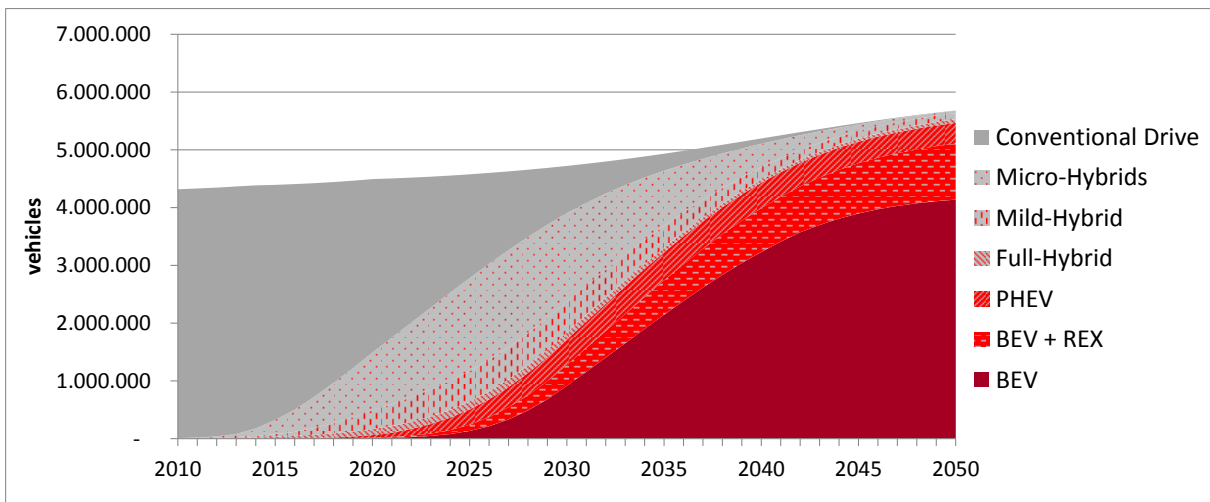

Figure A-5: Fleet development 2010-2050 in the "Policy-Scenario".

The results point out, that considerable effects on fleet diffusion of EVs (PHEVs & BEVs) can only be seen in a long run. This is mainly because of the slackness of market adoption of new technologies and the generally slow fleet modernization. Up to 2020 the share of EVs in

the fleet is only 1 %. However, in the following decade there is a strong increase that leads to a fleet share of around 35 % in 2030.

This scenario should demonstrate that a transition toward electric propulsion technologies can be achieved in a long run if the way is paved by implementing appropriate policy measures in the upcoming years.

A 2.3 Electricity actors and their role in liberalized Austrian electricity market

The Austrian electricity market has been operated by the cooperation of all market players since the full market liberalization on 1 October 2001. The processes, relationships and cooperation between these market participants are established by special market rules. The Austrian electricity market consists of:

1. Control area managers (CAMs)
2. Clearing and settlement agents (APCS)
3. Transmission system operators (TSOs)
4. Balancing group representatives
5. OeMAG (settlement agent for green electricity) (German: Abwicklungsstelle für Ökostrom AG)
6. Distribution system operators (DSOs)
7. Suppliers
8. Generators
9. Electricity wholesalers, retailers and traders

The description of the mentioned players/Stakeholders is based on information of the Austrian regulator, E-Control [5].

A 2.3.1 Control area manager (CAM)

Control area manager is an independent entity which is responsible for the supervision and regulation of power flows in a specified area (control area). The European interconnected grid (SYNCHRONOUS AREAS) is divided into a large number of control areas. Each control area describes generally the area within a country with some exceptions like Austria (two control areas) or Germany (four control areas). The existing power lines which cross the border between the neighboring control-areas are equipped with power smart meters. They transmit the collected data to the responsible CAM. The CAM calculates beforehand how much energy electricity must be cross the border in order to fulfill the supply contracts. Therefore the power stations are operated according to the resulted production schedules.

CAM tasks [5]:

- Continuously measure demand within their control areas.

- Transmit these meter readings to the clearing and settlement agent, which calculates the amount of balancing energy required on the basis of the difference between forecasts and actual supply and demand.
- Bill the clearing and settlement agent for the balancing energy required.

A 2.3.2 Clearing and settlement agents

Clearing and settlement agents are individuals or entities with official licenses to operate a settlement agency. This agent is called APCS Power Clearing and Settlement AG in Austria.

APCS tasks [5]:

- Calculate the difference between the balancing group representatives' forecasts and actual flows metered by the system operators.
- Bill the balancing group representatives for the balancing energy required.
- Pay the control area managers for the balancing energy required.
- Obtain offers of balancing energy from generators and compile merit order lists on the basis of these bids.

A 2.3.3 Transmission system operators

Transmission system operators [5] are responsible for performing the functions of a network operator and for transiting electricity.

A 2.3.4 Balancing group representatives

A balancing group consolidates suppliers and consumers into a virtual group, within which supply (procurement schedules and injection) and demand (delivery schedules and withdrawals) are balanced. It requires both a clearing and settlement agent and a balancing group representative to function.

All market players are obliged to join balancing groups. They supply power to and/or procure it from their balancing groups. The purpose of a balancing group is to even out supply and demand fluctuations. The balancing group representatives represent their groups in dealings with other market players.

Balancing group representatives Tasks:

- Obtain day a head consumption forecasts from all the suppliers in their balancing group.
- Send these forecasts to the clearing and settlement agent.
- Pay the clearing and settlement agent for the balancing energy.
- Bill the suppliers for the balancing energy required.

A 2.3.5 The distribution system operators

DSOs [5] are obliged to transport electricity in accordance with the existing contracts between generators and withdrawers, in return for payment of the regulated system charges. They must

take any action necessary, under the prevailing technical circumstances, to maintain network stability. In particular, they must make long-term investments to maintain the operability of their networks.

DSOs tasks:

- Conclude system access contracts with their customers.
- Deliver electricity to their customers.
- Meter consumption and attribute it to the balancing groups responsible for it.
- Transmit consumption data to the clearing and settlement agent.

A 2.3.6 Suppliers

Suppliers are responsible for delivering electricity to their customers. Since October 2001 the system operators have been obliged to grant all suppliers non-discriminatory access to their networks. As a result all consumers have a choice of suppliers.

Supplier's tasks are:

- Conclude supply contracts with their customers.
- Notify their balancing group representative of their customers' day ahead requirements.
- Bill their customers for the consumed power.

A 2.3.7 Consumers

Since 1st October 2001 all consumers – households, small and medium-sized, and large businesses – have been free to choose their suppliers.

Consumers tasks:

- Conclude supply contracts with their suppliers.
- Pay their suppliers for the consumed power.

A 2.3.8 Generator

Generator is a natural person, legal entity or partnership that generates electricity. Generator tasks are:

- Conclude contracts with electricity suppliers or OeMAG (the green power clearing and settlement agent)

A 2.3.9 Electricity wholesalers

An electricity wholesaler is a natural person, legal entity or partnership gainfully selling electricity. An electricity wholesaler performs no transmission or distribution functions either inside or outside of the network in which it operates. Electricity wholesalers tasks are:

- Conclude contracts with generators.

- Conclude contracts with electricity suppliers and/or other electricity wholesalers or traders.

A 2.3.10 OeMAG

OeMAG (settlement agent for green electricity) has been responsible for settlement of produced renewable energy in Austria since 01/01/2007. OeMAG tasks are [6]

- Buy-off of green electricity based on regulated renewable energy feed-in tariffs
- Calculation of green electricity's share
- Daily assignment of green electricity due to its calculated share to the electricity traders
- management of the new created feed-in mechanism for renewable energy
- processing of applications for support

The interactions between the described stakeholders within the electricity market are shown in Figure A-6. The relationships between the market participants are divided into different segments called:

- Data flow segment which describes the information transformation between the stakeholder in conjunction with performance of their responsibilities within the energy sector
- Cash flow part describes the monetary interactions between the above described stakeholders.
- The needed interactions for physically transport of produced energy to the end consumer have been described in business actions.

Figure A-6 includes also the interactions between the involved stakeholder for providing of control energy which is consisted of tertiary, secondary and primary control energy within a TSO-control area. The providing of control energy and the installed markets in a control area due to ensure the needed energy builds also an important part of the whole energy system. The control energy will be produced through the generation plants with an appropriate contract with responsible party (TSO or APCS in Austria). It is divided into primary, secondary and tertiary control energy markets (an open market for secondary energy in APG (Austrian power grid)-control area is expected to be introduced in 2012). Their activation based on frequency deviation in transmission grid and a sequentially control program.

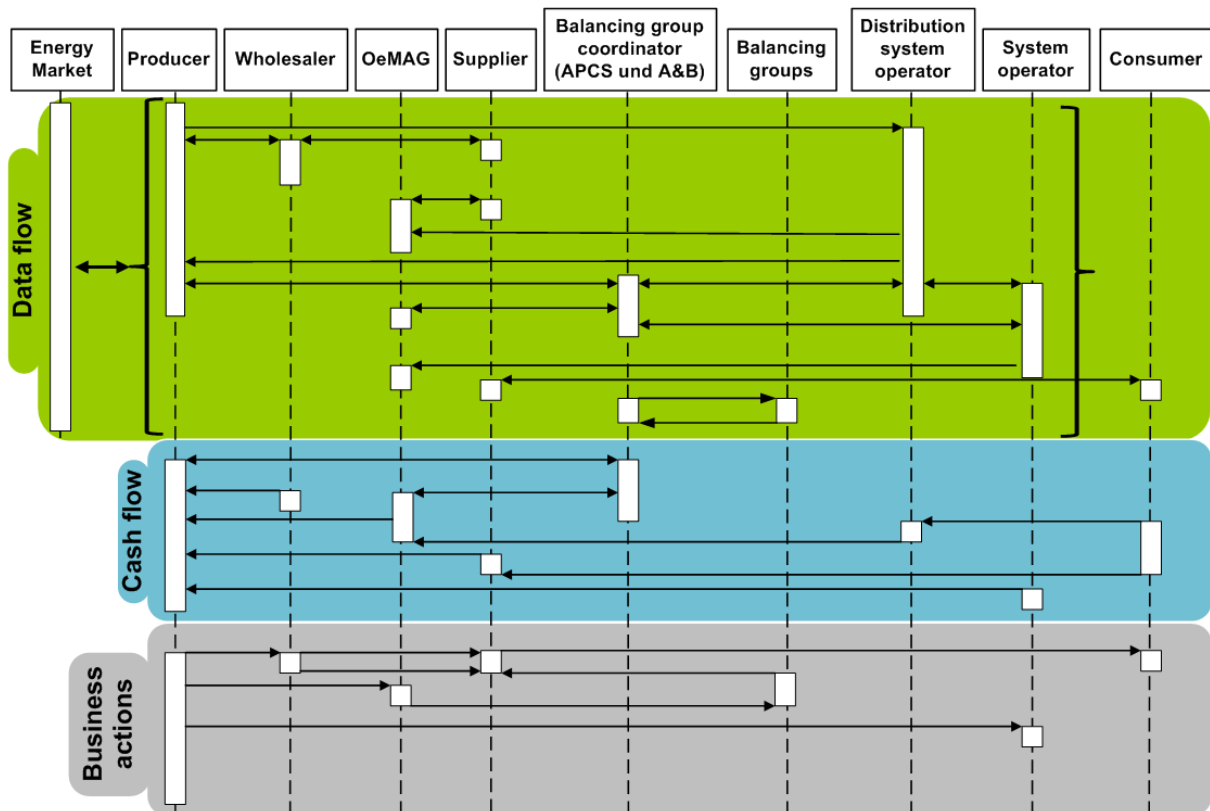

Figure A-6: Stakeholders and their interactions in liberalized Austrian electricity market

The aim of primary reserve is the stabilization of system's frequency in case of a frequency deviation from 50 Hz (± 20 mHz). A further deviation in a range of ± 180 mHz activates the whole reserved power for primary control energy. The activation of secondary reserve takes place within seconds until max 15 minutes automatically. The tasks of secondary reserves lie in restore the normal value of frequency before the deviation and free the primary control reserves for possible further frequency deviation [7]. In [8] it is mentioned that the secondary reserves also stabilizes the scheduled energy flow between different control areas.

The tertiary control will be activated manually, if the deviation could not be restored within the activation time of secondary reserve (at least after 15 minutes). This method frees secondary reserves for the next possible deviation. Figure 4 describes the activation of the mentioned control reserves in a case of frequency deviation. Generally, the unbalance between the energy production and consumption is the reason for frequency deviation within the electricity grid. A higher electricity generation or lower consumption (forecasting error) shows itself in higher system frequency. In this case, the reduction of production and increasing of consumption are possible solutions for influencing the system frequency in opposite direction.

Based on the described current situation in Austrian energy market, involved stakeholder and with respect to existing control energy markets the integration of EVs will be described in chapter 4. The chapter 5 includes a short description of possible business models and the involved stakeholders.

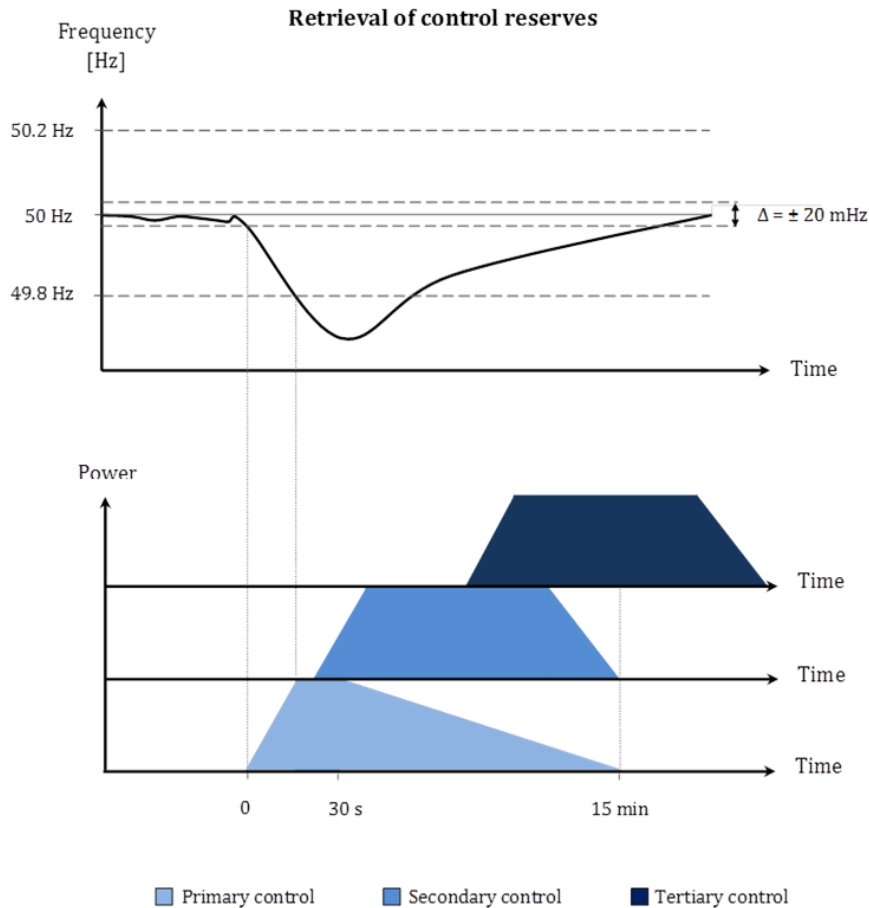

Figure A-7: Retrieval of control reserves ([9])

A 2.4 Integration of EVs into the Austrian energy system

The integration of EVs (EDVs) could be realized by the introduction of a new stakeholder called “Aggregator” or “e-mobility provider”. The authors in [10] mention the integration of a third party (aggregator) as a possibility for managing charging and discharging behavior of PHEVs. These strategies could support the balancing between generation and consumption in an energy system. [11] proposes different business models for V2G utilization. One of them integrates an aggregator in conjunction with V2G for selling the battery energy with creating financial incentives for vehicle owners (without providing charging and discharging schedules). [12] suggests the integration of an aggregator, who is responsible for planning and operation activities including load management and V2G. Due to integration of renewable energy the authors in [13] describe EVs as grid assets with considerable flexibility. This could be supported by appropriated and optimized charging and discharging strategies, which will be provided by an EV-aggregator. The Aggregator will also present the EVs on the electricity market. He can provide the charging/ discharging strategies based on market rules, current system situation and driving patters of his fleet. The EU commission task force for smart grids [14] describes Aggregator as:

Aggregator offers services to aggregate energy production from different sources (generators) and acts towards the grid as one entity, including local aggregation of demand (Demand

Response management) and supply (generation management). In cases where the aggregator is not a supplier, it maintains a contract with the supplier.

Figure A-8 shows a possible integration of the mentioned new stakeholder -Aggregator- in the Austrian electricity sector. The figure shows that the electric vehicle users or owners will have only a contract with the Aggregator (e-mobility provider / service provider). The aggregator overstrains the interactions with other market stakeholders. Therefore, he can provide / offer his EV-fleets different types of charging and discharging strategies, which conform to defined target functions (minimizing the charging costs, charging in times with renewable production and so on).

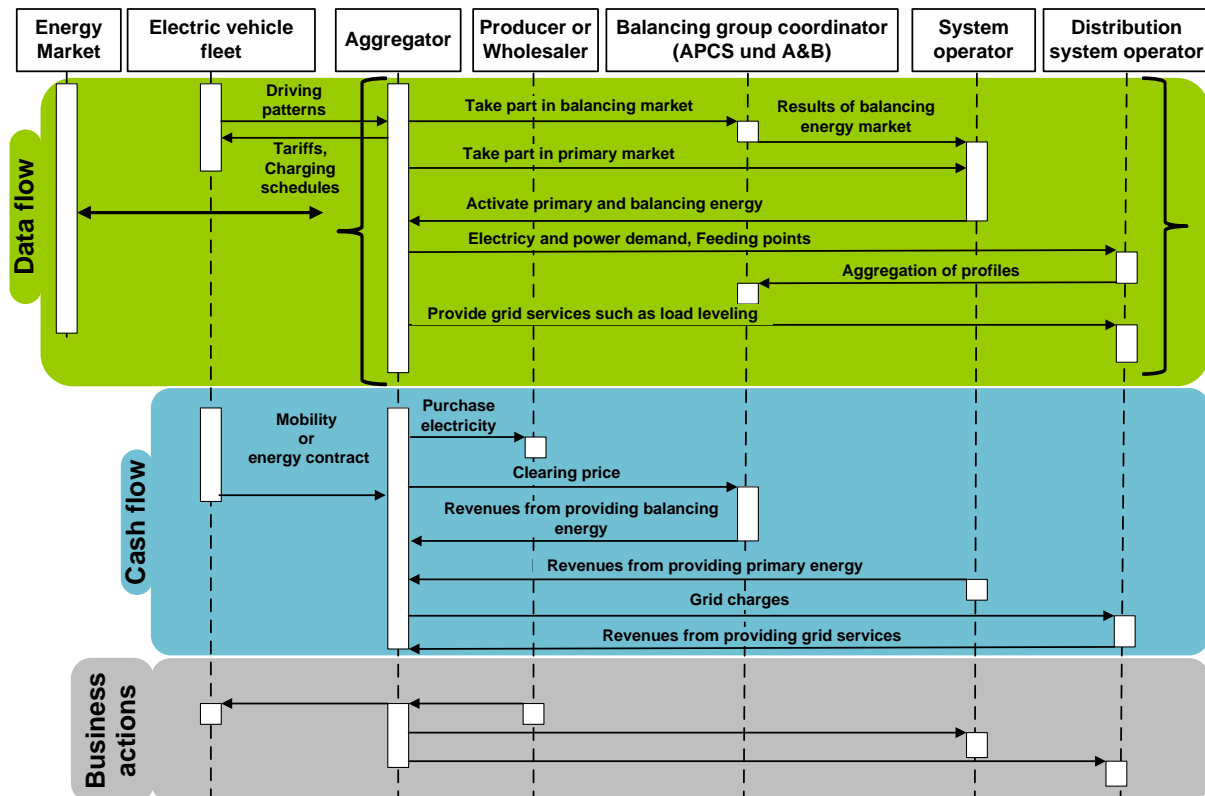

Figure A-8: Involved Stakeholder for integration of EVs in the Austrian energy system

Therefore, the aggregator needs different information about his managed fleet such as

- driving patters,
- battery capacities,
- plug-In times,
- connection power,
- distribution of charging infrastructure (secondary infrastructure (charging station in public areas)).

A sufficient integration of the aggregator would be complemented due to a good understanding of the functioning of existing markets rules (energy and control energy markets). The creation of appropriate charging/discharging strategies must happen with considering of local grid situation (collaboration with DSO or DNO). This will result in lower

investments in distribution grids (suitable for national economy) due to high penetration of EVs in an electricity system (minimizing of investments in grid reinforcements (medium-and low voltage grids) and assets).

A successful integration of EVs and the complementary aggregator in an energy system based on adequate business models should ensure a fair distribution of added values to involved participants. From the aggregator's point of view the EV business models could be separated in two main categories:

- 1) Business models based on controlled charging / discharging strategies: The mentioned strategies could result from different target functions like :
 - a) Participation of EVs on energy markets by using the spread between peak and off-peak prices (Cost optimized charging strategies: charging during off-peak times)
 - b) Participation of EVs on positive and negative control energy markets (see chapter 3)
 - c) Grid based charging/ discharging strategies
 - d) Renewable charging strategies: Charging even in times with energy generation due to renewable power plants
- 2) Second life business models:
 - a) Re-using the vehicle battery after the vehicle lifetime is reached for e.g.
 - i) Renewable energy power storage
 - ii) Grid load adjustment: storing the energy during the off-peak time and feeding it back during the peak periods
 - iii) User application: backup power supply for specific application e.g. industry and health sector, reduction of energy costs for industry

The next chapter describes several use cases that could be mentioned with the first business model category. The use cases will be described considering affected stakeholders in the electricity sector. The second life business models take into account all options of stationary storages but are not the focus of this report.

A 2.5 EV use Cases (controlled charging/ discharging strategies)

The defined use cases are based on the location of the charging points. According to [1], [15] and discussion with stakeholders like different Austrian DSOs and E-mobility providers specific use cases are defined for:

1. Charging at home,
2. Charging at office/company,
3. Charging at public charging stations,
4. Charging at private charging station.

The last part of the charging places –charging at private charging station- is a special case. The private charging spot operator provides for EVs to charge at different charging levels (in a range of 22 kW and higher, Table A-1 shows the power charging modes after the definition of Focus Group on European Electro-Mobility [16]) or the possibility for battery switching. It means that the goal of a private station is fast charging due to dealing with higher range needs. Hence, the charging character is an uncontrolled one because of immediate power needs and an unknown number of costumers, needed charging energy, preferable charging power and mainly the intention for fast charging (low plugged-in periods).

Table A-1: Modes of charging and charging level (see [16])

Power nomination	Main connection	Power, kW	Power, Amps
Normal power	1-phase AC connection	≤ 3,7	3.7
Medium power	1- or 3-phase AC connection	3.7 - 22	16-32
High power	3-phase AC connection	>22	>32
Hich power	DC connenction	>22	>32

Hence, the discussion of the business model in conjunction with controlled charging (G2V)/discharging (V2G) are focused at charging at home, office and public charging stations. The business models thus could be realized for them. The ownership for the required equipment (charging point with integrated smart meter, communication infrastructure between aggregator and the EVs, aggregator energy management system (software, hardware)) for controlled charging/ discharging could be depicted as follow:

- Charging at home/office/company: The charging point including the attached smart meter belongs to the building owner/ vehicle owner.
- Charging in public area: Here it is assumed that the establishment and distribution of the charging stations will be conducted by a local DSO. Thus, they belong to him.
- Communication infrastructure: In conjunction with G2V and V2G (e.g. control energy and intraday market) applications a real-time communication will be needed. This ensures a data transformation without delays to the integrated smart meter in the charging stations. Furthermore, the charging station takes over the communication with the EV on-board charging controller. E.g. the use of a GSM-based infrastructure through an aggregator can be based on flat rate contracts with an appropriate provider.
- Aggregator energy management system: The aggregator uses the system for the purpose of managing the controlled charging and discharging. A bidirectional communication system between the named equipment is assumed to be necessary.

Figure A-9 shows the use case for G2V and V2G applications for the charging point at home separated in 3 areas data flow, equipment for realization of V2G concepts and physical system integration. The use case allows the EVs to participate in G2V and V2G concepts before the first and after the last daily EV usage. As mentioned, the aggregator takes over the whole interactions between the EVs and other stakeholders in the electricity market. Even more, a V2G-Inverter will be needed for providing power from the battery into the grid. It is assumed that the aggregator is the owner of the V2G-Inverter because of his ambition to participate at the energy market (the vehicle owner could also be the owner to cover the own home electricity consumption in peak periods (charging the vehicle e.g. through the home PV plant)).

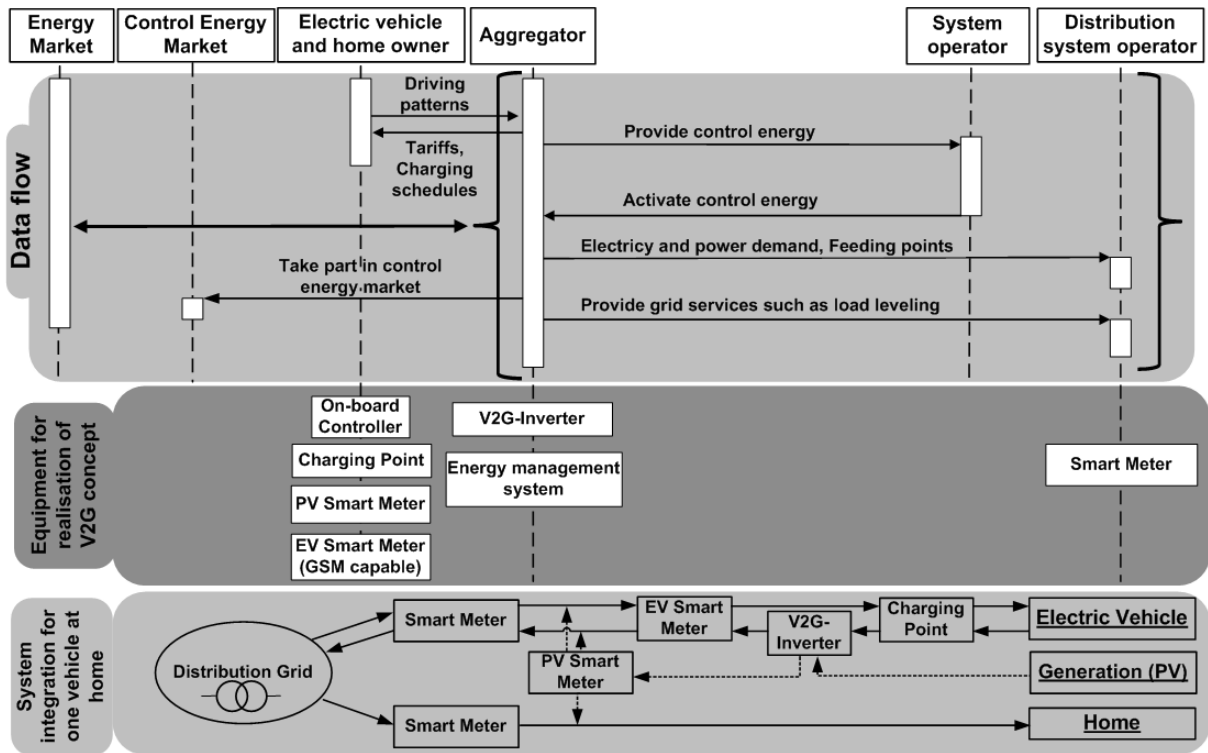

Figure A-9: V2G- business model for feed-in energy from the vehicle into the grid (see [17])

Table A-2 shows use cases and provided services for business models based on controlled charging and discharging strategies with different target functions. Table A-3 presents involved electricity stakeholders in business models based on controlled charging and discharging strategies with different objective functions. The below tables comprise a comprehensive overview of discussed use cases, provided services and involved stakeholder due to realization of controlled charging/ discharging strategies.

Table A-2: Use cases and provide services for business models based on controlled charging and discharging strategies with different target functions

Business models based on different charging and discharging strategies	Charging stations				Providers of Services		
	Home	Office/ Company	Public area	Private charging station	Control energy	Service providers for DSO	Technology providers
EVs, uncontrolled charging	+	+	+	+			
EVs, Controlled charging (e.g. low-cost charging)	+	+	+			+	+
EVs, provide power for control energy market	+	+	+		+		+
EVs, controlled charging strategy due to DSO-needs (e.g. load leveling, PV- based charging strategy)	+	+	+			+	+

Table A-3: Involved electricity stakeholders in business models based on controlled charging and discharging strategies with different target functions

	Grid and system operators		Energy market stakeholder				Policy makers and regulation authorities		
	TSO (APG)	DSO	Energy market	Control energy market	Balancing group coordinator (APCS)	Aggregator/ Supplier	Regulator (E-Control)	Policy	Other decision makers
Business models based on different charging and discharging strategies									
EVs, uncontrolled charging		+				+	+		+
EVs, Controlled charging (e.g. low-cost charging)		+	+			+	+		+
EVs, provide power for control energy market	+	+		+	+	+	+	+	+
Evs, controlled charging strategy due to DSO-needs (e.g load leveling, PV- based charging strategy)		+	+			+	+	+	+

A 2.6 Conclusion

A 2.6.1 Market diffusion of EVs

Market diffusion of plug-in-hybrid (PHEV) and battery electric cars (BEV) is strongly dependent on economic and political framework conditions. In order to address a mass market they have to be competitive with conventional cars in terms of total costs. The key factors for competitiveness today are battery costs and fuel prices. Battery costs have decreased considerably in the past years and global effort in this field is likely to lead to further reductions. However, fuel prices are a major uncertainty. Past analyses have shown that a considerable increase in price of gasoline and diesel is required for PHEVs and EVs to become cost effective. It is questionable whether these price levels will ever be reached with crude oil price as only driver. Alternatively, fuel taxes can be applied to reach these price levels. An increase in taxes on transport fuels will lead to a higher demand for fuel efficient cars and consequently to a stronger diffusion of electric propulsion technologies, however with the effect of cost of transportation increasing. Together with other tax instruments, such as efficiency-dependent registration taxes, this will lead to an efficiency improvement of the fleet and accelerate the diffusion of PHEVs and EVs.

A 2.6.2 Market Integration of EVs

The integration of the mentioned agent with the responsibilities of an aggregator could be realized with:

1. The extension of a current stakeholder such as an advanced retailer with added responsibilities like managing the EVs charging/ discharging strategies and diffusion/development of charging points in certain areas (except public areas, see chapter 5). The advanced retailer would act with his fleet and the mentioned strategies as an energy consumer and as a producer/ power provider for different ancillary services, simultaneously. Thus, the charging/discharging strategies of EVs could fulfill different target functions of DSM. Due to a high penetration of EVs, the charging/ discharging strategies could take the security of the grid into account (load management). This can be accomplished by considering of coming needs from the DSOs. Therefore, the cooperation between aggregators and DSOs in conjunction

with DSM-application and grid security (controlled charging/ discharging strategies) will be needed.

2. The establishment of new actors in an enhanced regulatory framework: This way leads to the integration of a new stakeholder with the defined responsibilities for an advanced retailer. This way may result in a change of each stakeholder's framework conditions and would be more time intense and costly compared to the alternative mentioned in point 1.

If charging stations are available and they could be controlled by an aggregator depending on penetration of EVs, there would be a corresponding and significant load control potential, respectively.

References of the Austrian EV stakeholders report

- [1] M. Kloess, “Potentials of hybrid and electric cars to reduce energy consumption and greenhouse gas emissions in passenger car transport –Techno-economic assessment and model-based scenarios,” Vienna University of Technology, Vienna, 2011.
- [2] M. Kloess and A. Müller, “Simulating the impact of policy, energy prices and technological progress on the passenger car fleet in Austria—A model based analysis 2010–2050,” *Energy Policy*, vol. 39, no. 9, pp. 5045-5062, Sep. 2011
- [3] Zhe L., Minggao O. (2011): “A win-win marginal rent analysis for operator and consumer under battery leasing mode in China electric vehicle market”, *Journal Energy Policy*, doi:10.1016/j.enpol.2011.03.014
- [4] APCS (2011): “Definition of Balancing Group Coordinator in liberalized Austrian electricity market”, Information from the established balancing group coordinator in Austria, <http://en.apcs.at/company/> (27.10.2011, 10:22)
- [5] E-Control (2011): “Player on the Austrian electricity market”, Information from the regulator (public authority) in Austria, http://www.e-control.at/de/market_players/electricity/electricity-market/players (27.10.2011, 11:40)
- [6] OeMAG (2011): „Description of OeMAG Tasks, settlement agent for green electricity in Austria“, URL: <http://www.oem-ag.at/company/> (27.10.2011, 12:40)
- [7] UCTE OH – Policy 1 (2009): Load-Frequency Control - Final Version (approved by SC on 19 March 2009)
- [8] Galus M. D., Zima, M., Andersson, G. (2010): On Integration of Plug-in hybrid electric vehicles into existing power system structures, *Energy Policy*, doi:10.1016/j.enpol.2010.06.043
- [9] Marvin Steinböck: Integration of electric vehicles in a smart grids platform: The case of Austria, Master thesis, Vienna University of Technology, Institute for energy systems and electrical drives, April 2011
- [10] Kristien Clement-Nyns, Edwin Haesen, Johan Driesen (2010): The impact of vehicle-to-grid on the distribution grid, Paper in journal *Electric Power Systems Research*, doi:10.1016/j.epsr.2010.08.007
- [11] Willett Kempton, Jasna Tomic' (2004): Vehicle-to-grid power implementation: From stabilizing the grid to support large-scale renewable energy, *Journal of Power Sources*, doi:10.1016/j.jpowsour.2004.12.022
- [12] Matthias D. Galus, Marek Zima, Göran Andersson: On Integration of Plug-in hybrid electric vehicles into existing power system structures, *Energy Policy*(2010), doi:10.1016/j.enpol.2010.06.043
- [13] Trine Krogh Kristoffersen , Karsten Capion , Peter Meibom (2011): Optimal charging of electric drive vehicles in a market environment, *Journal Applied Energy*, doi:10.1016/j.apenergy.2010.12.015
- [14] EU-Smart Grids (2011): EU Commission Task Force for Smart Grids, Expert Group 3: Roles and responsibilities of Actors involved in the Smart Grids Deployment, EG3

Deliverable, 04. April 2011, URL:

http://ec.europa.eu/energy/gas_electricity/smartgrids/smartgrids_en.htm (23.11.2011)

[15] Tomás Gómez San Román T. G., Ilan Momber, Michel River Abbad, Álvaro Sáneh Miralles (2011): Regulatory and business models for charging plug-in electric vehicles: Infrastructure, agents, and commercial relationships, paper Energy policy, doi:10.1016/j.enpol.2011.07.037, 2011

[16] CENELECT (2011): Focus Group on European Electro-Mobility, Standardization for road vehicles and associated infrastructure, Report in response to Commission Mandate M/468 concerning the charging of electric vehicles, URL: http://www.cen.eu/cen/Sectors/Sectors/TransportAndPackaging/Roadtransport/Pages/Electric_vehicles.aspx, June 2011

[17] Rusbeh Rezaia, Wolfgang Prügler (2011): Assessment of Business models for E-Mobility in APG control area, Paper, Journal elektrotechnik und informationstechnik (e&i), submitted 2011

Appendix 3 Tariff scheme options for distribution system operators'

Preface

This research report provides the results of the research project “Tariff scheme options for distribution system operators”. The research was conducted by a research group of LUT Energy, the members of which were Professor Jarmo Partanen, Dr. Samuli Honkapuro, Jussi Tuunanen, M. Sc. (Tech), and Dr. Hanna Niemelä. The research was funded by the Finnish Energy Industries and the Finnish Electricity Research Pool.

The project steering group comprised the LUT Energy researchers and Kenneth Hänninen (the Finnish Energy Industries), Simo Nurmi (Energy Market Authority), Markku Kinnunen (Ministry of Employment and the Economy), Antti Martikainen (Savon Voima Verkko Oy), Jouni Lehtinen (Helen Sähköverkko Oy), Bengt Söderlund (Fortum Sähkönsiirto Oy), Arto Gylén (PKS Sähkönsiirto Oy), Ville Sihvola (Elenia Verkko Oy) and Pertti Kuronen (Fingrid Oyj). The steering group held four meetings during the research project. Ideas were also actively exchanged by email. Moreover, a workshop with 28 participants was organised for the distribution system operators and other stakeholders in Tuusula on 23 January, 2012.

The researchers express their gratitude to the steering group and the participants in the workshop for their active supervision of the research and valuable ideas and comments.

A 3.1 Introduction

Significant changes are taking place in the generation and end-use of electrical energy. The principal target of these changes is savings in the primary energy and reduction in energy production emissions. Here, deployment of renewables such as wind and solar energy and distributed generation play a key role. However, typical drawbacks of these forms of generation are their low predictability and small unit size. In the end-use, improvements in energy efficiency and controllability have an impact on both the volume and characteristics of electricity consumption. In addition, advancements in battery technology will open up new opportunities for the storage of electrical energy, thereby altering the nature of the whole power system. Moreover, smart grids enable flexible connection of distributed generation (DG), energy storages and controllable loads to the grid and their smart control.

In order for the above-described changes in the energy system to take place in a cost-efficient way from the perspectives of end-customers and enterprises in the field, demand response (DR) and related incentive tariff schemes are required both in the distribution and retail of electricity. Demand response enables distributed generation and an optimal use of the generation and network capacity. The improved capacity utilisation rate, in turn, reduces investment needs, thereby decreasing the costs to the end-customers in the long term. For distribution system operators (DSOs), improvements in energy efficiency and distributed energy storages will have an impact on the amount of electrical energy transmitted in the distribution systems, peak power and the temporal variation in power demand. As the peak power determines the network dimensioning requirements, and, on the other hand, the present

tariffs are based on the amount of transmitted energy, the above changes will influence both the costs and revenues of electricity distribution. For the energy sector, problems may arise, if the changes in energy and power are such that the prevailing tariff system is not able to respond to the revenue stream needs of the DSO in the new operating environment.

Furthermore, advancements in the control and metering of the customer gateway provide technical opportunities for more dynamic tariff schemes, by which the consumption behaviour of end-customers can be steered to a direction that is optimal for the electric power system. In that case, the end-use is efficient and scheduled to guarantee an optimal use of resources in generation, transmission and distribution alike. The starting point here is that the network has to enable market-based demand response, which, however, may not lead to network investments that are non-optimal for the national economy. Yet, in practice, demand that is optimised based on generation only may be non-optimal from the viewpoint of the distribution system, in which case the demand response products in electricity retail may produce conflicts of interest between the retailer and the DSO in the load control. With a suitable distribution tariff scheme, incentives can be provided for the consumers to optimise their electricity consumption so that besides the customer and the retailer, also the DSO benefits from the demand response.

The objective of the research is to study which opportunities and requirements the future operating environment provides for a distribution tariff scheme for DSOs. The research investigates how different tariff schemes encourage customers in energy efficiency, how they enable introduction of active resources such as demand response, and how they guarantee an optimal use of the distribution network capacity and appropriate revenue streams for the DSO. The primary target is to analyse what kind of a tariff scheme ensures the cost reflectivity of customer invoicing and an optimal use of the distribution system capacity, simultaneously allowing the market-based demand response of small-scale customers. The study focuses on small-scale customers; in practice, low-voltage customers, who at present do not have a power tariff of their own in Finland.

The structure of the report is as follows. Chapter 1 concludes with a brief review of the research conducted recently on the topic. Chapter 2 discusses the effects and target state of the distribution network tariff schemes from the viewpoints of different stakeholders. The chapter also analyses the boundary conditions for the development of the tariff scheme. Chapter 3 addresses the present tariff schemes and their key development needs in Finland. Chapter 4 introduces potential tariff schemes, and Chapter 5 concentrates on power band pricing and its effects. Chapter 6 provides conclusions, and Chapter 7 discusses the future research needs on the topic.

A 3.1.1 Previous research on tariff schemes

Kärkkäinen & Farin (2000) have investigated distribution tariff schemes in distribution networks soon after the opening of the Finnish electricity market. The study lists the most common requirements for the tariff schemes, such as cost reflectivity, equal and non-discriminating treatment of customers, freedom of choice, intelligibility, consistency and steering properties. It has been shown that these requirements are somewhat contradictory, because for instance full cost reflectivity would require complicated and geographically varying tariffs, which would be against the requirements set for spot pricing and intelligibility of the tariffs. Considering the steering aspects of tariffs, it has been suggested that the tariffs

should encourage efficiency in the network dimensioning and the use of network capacity, simultaneously promoting efficient use of energy. The study considers the proportions of fixed charges and energy rates in the tariffs of the DSOs. The fixed charges are shown to vary between 0 and 80 %, depending on the DSO and the customer group. Hence, it has been concluded that the decision on the proportions of fixed charges and energy rates should be left to the DSOs.

Evens & Kärkkäinen (2010) have studied pricing mechanisms and incentive systems by which demand response can be promoted. The study provides a review of the theory related to the pricing mechanisms and analyses 15 pilot studies. The study focuses on both network and retail tariffs, and the incentive systems are divided into price- and incentive-based ones. In the price-based systems, the consumer prices vary, and the consumer's response to changes in prices is voluntary. In incentive-based systems, the consumers receive compensation, if they allow load control. Considering the research on distribution tariffs, a highly relevant observation is that in Norway the regulator has banned the DSOs from using Time-of-Use tariffs (ToU), because they are suspected to cause potential disturbance to the normal market operation.

Similä et al. (2011) have investigated the distribution network tariff scheme in a smart grid environment by a literature review, economic theory and simulations. The simulation results show that the end-customer benefits most when the retail and distribution tariffs are dynamic (in practice, a tariff based either on market price or time of use). In addition, it is stated that dynamic tariffs improve the cost efficiency of the DSO; however, the incentive effects of dynamic tariffs may be problematic to the DSO, because the customers' responses to the load control lead to a decrease in the company revenues, while the short-term costs remain unchanged. Thus, the prices have to be raised in order to cover the costs, which, for the customers, is negative feedback on their responses to the incentive system. Furthermore, the study recognises problems related to the load control performed by the DSO. As to this, it is concluded that the network tariffs should be static, and only the retail tariffs could vary dynamically within a day. If the DSO wishes to use load control to balance the network load, it should buy the load control from the retailer.

A.3.2 Effects of the distribution network tariff scheme and boundary conditions for development

The starting point for a pricing structure of energy services, such as electricity distribution, has to be in encouraging the energy efficiency of the system as a whole and in minimising the environmental effects and costs of energy generation to the national economy. In practice, this means measures to enable distributed generation and demand response, optimisation of the use of generation, transmission and distribution capacity, and minimisation of fuel and other variable costs. Here, it is emphasised that both energy and power have an impact on the overall energy efficiency of the electric power system, and therefore, a pricing system that only encourages in minimising the energy use does not necessarily produce an optimal result, but incentives are required to reduce the peak power and optimise the temporal variation of power.

When considering the pricing of electricity distribution, we may state that in addition to the above targets, the pricing system has to ensure reasonable and predictable revenue stream and encourage the customers to control their electricity use in a way that is optimal for the

distribution system. As there are also other players in the electricity market besides customers and DSOs, such as producers, retailers and the transmission system operator (TSO), the interests of these stakeholders have to be taken into account in an optimally designed distribution tariff. For instance, a distribution and retail tariff may not produce control signals that conflict with each other. Furthermore, a customer's opportunities to operate have to be safeguarded by ensuring the reasonableness, intelligibility and feasibility of pricing and the related incentive elements for a common electricity end-user. The above-described requirements can be expressed by stating that a distribution tariff shall balance the maximisation of national economic profit and minimisation of the adverse effects experienced by an individual customer.

According to a survey by Nemesys (2005), all the interest groups put special emphasis on stability when considering the criteria for a well-functioning regulatory model. Figure A-10 shows that stable tariffs are equally important or even more important than low tariffs for all interest groups. Although the emphasis in this study is on the regulatory model, the results can be extended, at least in this respect, to cover the targets set for the tariff scheme.

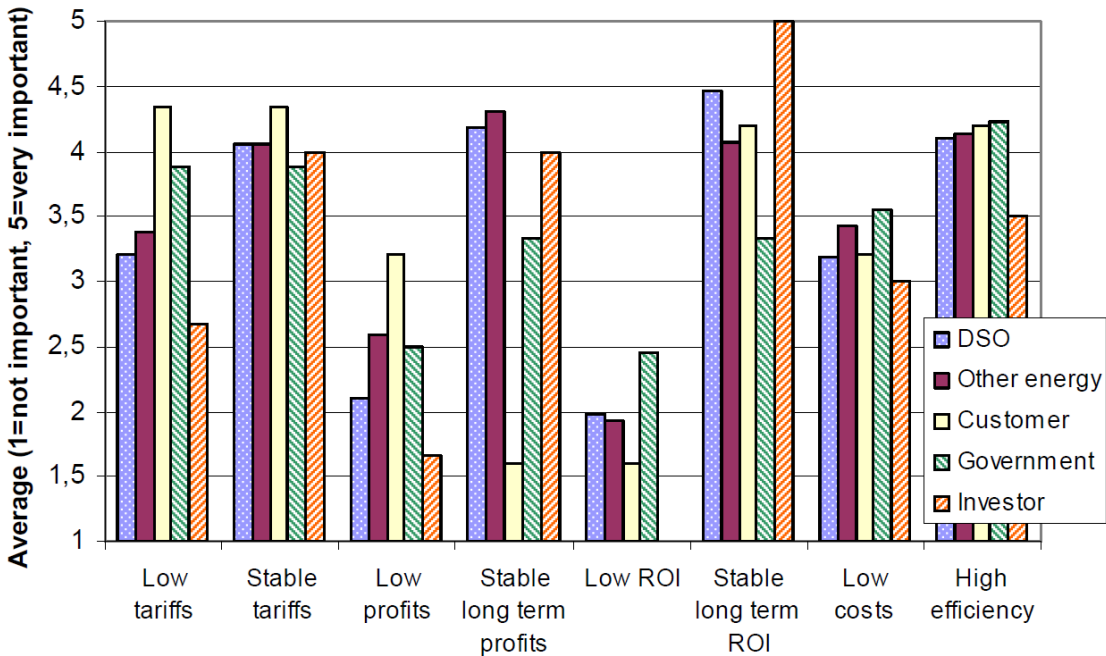

Figure A-10: Relative importance of economic aspects in a well-functioning regulation system (Nemesys 2005).

The following sections discuss the objectives and effects of the distribution network tariff scheme in more detail from the perspectives of different interest groups.

A 3.2.1 Distribution system operator perspective

From the perspective of a distribution system operator, the tariffs shall guarantee an adequate and predictable revenue stream, which enables the construction, operation and maintenance of a distribution system that meets the requirements set by the customers and the operating environment. In addition, the tariff scheme has to be cost reflective to ensure that changes in the use of electricity affect the revenues and costs as equally as possible. The distribution

network components, such as conductors and transformers, are dimensioned according to the power demands of the network. Hence, the dimensioning of these components is influenced both by the power demands of individual customers but also by the peak power of a larger customer volume (supply area of a distribution transformer, feeder, primary substation), which, again, is affected by the intersecting load curves of individual customers. In the electricity distribution operations, energy-based cost factors are basically comprised of the load losses on the network and the charges of the transmission system operator. On the other hand, costs that depend on the number of customers include metering and billing and, to a certain degree, administrative costs. The network operation costs, such as operation, maintenance and fault repair, mainly depend on the scope of the network and the operating environment. Figure A-11 illustrates a typical cost distribution of a distribution system operator. The figure shows that capital costs (investments and financing), which depend mainly on power, account for more than half of the costs. The costs of the main transmission grid, similarly as the distribution network costs, are chiefly dependent on power, but the invoicing in the main transmission grid is based on the volumes of transmitted energy. Thus, only the network losses constitute a cost component that is chiefly dependent on energy. The losses are divided into network and transformer losses, the latter of which can be further divided into load and no-load losses. Of these, only the transformer no-load losses are independent of the power transmitted on the network. Hence, less than 6 % of all costs are energy-based costs.

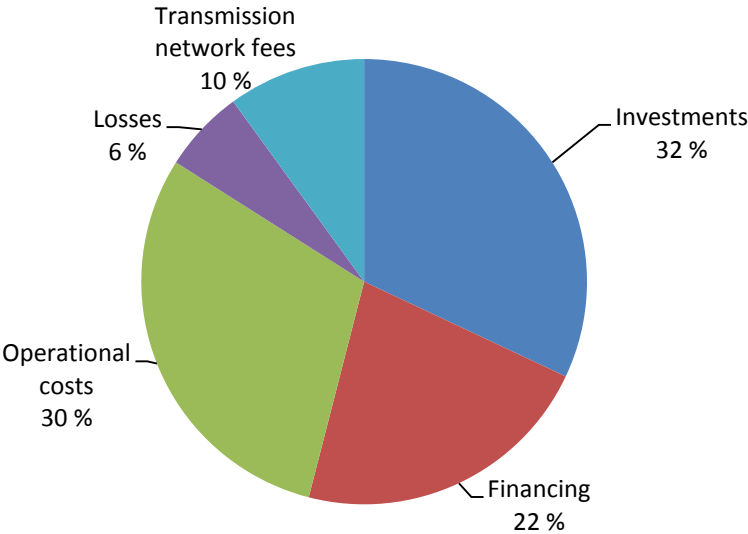

Figure A-11: Typical cost structure of a distribution system operator.

In addition to the revenue stream, the steering effects of pricing have to be taken into account. If the pricing is based solely on power or the use of energy, it steers the customers to optimise their energy use with the target to reduce the costs. Hence, the objective of the DSO is to generate a tariff scheme that encourages the customers to adjust their use of electricity to be optimal for the distribution system. In theory, in an ideal situation, the power demand would be as balanced as possible in order to make the maximum use of the network transmission capacity. In addition to the above, there is a technical requirement that the distribution tariff shall not require metering that would cause significant additional costs. The target is that the minimum requirements defined for metering in the Government Decree (66/2009) on

determination of electricity supply and metering are adequate for the implementation of the tariff scheme.

A 3.2.2 Customer perspective

The proportion of electricity distribution of a customer’s total electricity bill is approximately a quarter, as shown in Figure A-12. In the figure, the proportionally small cost component, that is, transmission on the main transmission grid (2 %) is billed also in connection with the electricity transmission on the distribution network. Electricity transmission on the distribution network, similarly as sales of other services, is subject to VAT, in addition to which the electricity taxes are charged to the customers in connection with the transmission of electricity. Nevertheless, the analyses in this study concentrate on the price of electricity transmission on the distribution network without taxes.

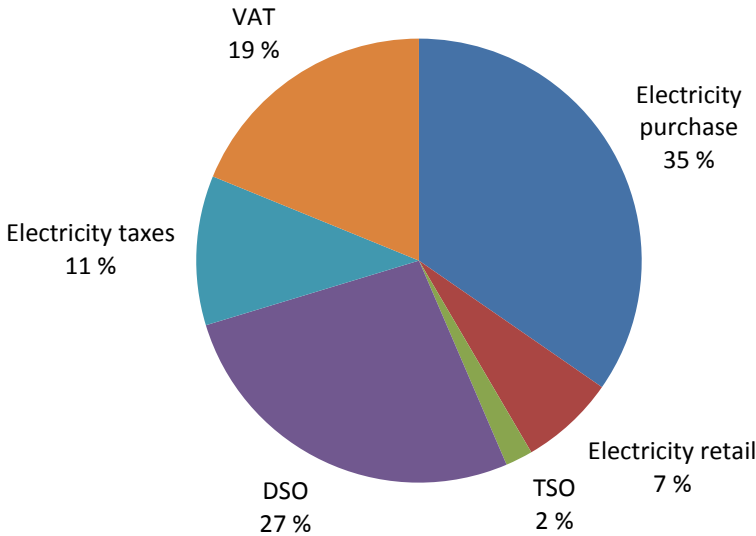

Figure A-12: Electricity price formation for a domestic customer on 1 February 2012 (EMA 2012a).

The figure above can be further divided into energy-based and fixed parts in the electricity bill. Energy-based items are the electricity purchase and retail and the VAT included in these, and the electricity taxes, while the transmission of electricity on the distribution network and on the main transmission grid are mainly power-based cost items. Figure A-13 depicts the information of Figure A-12 divided into energy-based and fixed charges, assuming that a fixed charge is used in the electricity distribution. The figure shows that also in this case 65 % of a customer’s electricity bill is comprised of energy-based charges, which guarantees that the billing encourages the customers to reduce their use of energy even if the distribution network tariff scheme is based on a fixed standing charge only.

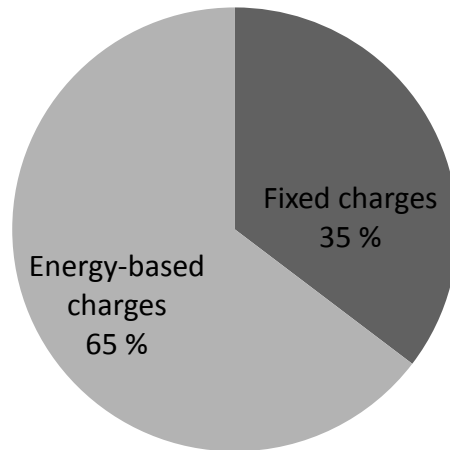

Figure A-13: Division of the electricity bill of a domestic customer into fixed and energy-based charges, assuming that the distribution tariff is based on a fixed standing charge only.

Favourable prices are naturally among the customers' primary interests. The pricing of the DSOs is supervised by a regulatory model, which in practice sets a maximum limit on the company turnover. However, the focus of this study is on the tariff scheme only, and it is assumed that the level of tariffs is sufficient for the DSO to guarantee adequate revenue streams required for operation. Besides favourable prices, a key pricing criterion for a customer is predictability, in addition to which the tariffs are expected to be intelligible so that the customer understands how the electricity bill is compiled and how he/she can affect his/her bill. As it was stated above, predictability is at least as important to the customer as the favourable pricing. Equal treatment of customers, on the other hand, requires that the tariffs are cost reflective and transparent. Moreover, the tariff should be compatible and in line with the retail tariff so that both tariffs encourage the customer to improve energy efficiency in the use of electricity and do not include any contradicting incentive elements.

Customers often see changes as negative occurrences. When the tariff scheme is reformed, it is inevitable that for some customers the prices will rise and drop for others, even if the turnover of the DSO remains unchanged, and the tariff scheme is now more cost reflective. When the target is to achieve a tariff scheme that steers the use of electricity in a direction that is more optimal for the whole energy system, we have to consider our priorities: the benefit of the national economy or an individual customer's security in the reform. The starting point is that the reform of the tariff scheme will steer the electricity users to make better use of the distribution capacity, which will lead to a decrease in the distribution costs in the long term. Thus, the reform will benefit the customers in the long term, even though the changes may have negative effects in the short term.

A 3.2.3 Impacts and opportunities of demand response

Vital for the energy system as a whole is that the distribution and retail tariffs together provide incentives for the electricity end users to act in such a way that the national economic benefit is maximised. When the objective is to optimise the utilisation of the generation and

network capacity, simultaneously promoting the use of renewables such as wind and solar power, the implementation of demand response plays a key role. In practice, demand response is carried out either manually by the customer or by active load control, or by remote customer load control according to the demand. The remote control is carried out either by the electricity retailer, aggregator or the DSO. In practice, load control has a significant impact on the retailer's electricity trade balance, and therefore, it is natural that the retailer takes care of the control. If the control were carried out by some other party, this would degrade the accuracy of the load forecast, thereby increasing the balance error and electricity purchase costs. However, the load control carried out by the retailer may in some cases have negative effects on the DSO. For instance, according to the objectives of the retailer company, an optimised demand response may increase the power peaks of the DSO, in which case the costs of the DSO will increase, while the retailer receives financial benefit from the load control.

An example of such a conflict of interest is illustrated in, where the Figure A-14 total power of a single medium-voltage feeder is demonstrated with the area price Finland in the spot market for one day (22 February 2010). The figure shows that the prices are highest during the lowest powers, and the latter price peak is removed close before the time instant of the peak power. If the customer loads were controlled based on the spot price, the demand would shift later from the moment of the first price peak, which would probably increase the power of the feeder.

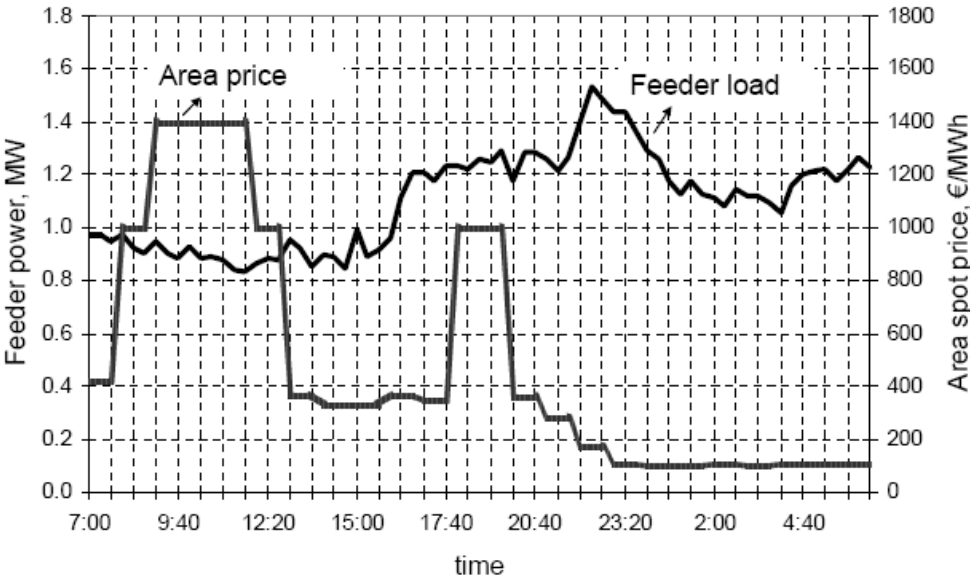

Figure A-14: Peak power of a medium-voltage feeder and the area price Finland on 22 Feb 2010 (Belonogova et al. 2010).

For an electricity retailer, the load control during price peaks would be very profitable. The retailer could either sell the excess electricity in the market or avoid expensive extra purchases. In the above situation, the area price varies between 100 and 1 400 €/MWh, while the price charged to a domestic consumer is 60–70 €/MWh (6–7 cent/kWh).

Again, the theoretical potential of load optimisation for the DSO can be assessed by a simplified example. The total amount of energy supplied by all DSOs to the customers was 52 TWh in Finland (2010). In the same year, the sum of the annual highest hourly mean power was 11 900 MW. Thus, the peak operating time of the networks is 4 380 hours, and the network capacity utilisation rate is 50 % (peak operating time/8760). It is pointed out here that the calculation is simplified, and the results vary considerably between the distribution system operators. However, the example allows us to assume that the volume of energy transmitted in the present distribution systems could be doubled, if the power demand were distributed evenly to every hour of the year. In Finland, the total replacement value of the distribution networks is about 14 billion euros, which, with a 40-year lifetime and 5 % interest rate, yields an annual cost of 815 M€/a. In practice, by the load control, the load peaks can be cut so that an increase in the energy consumption will not require extra reinforcement of the network. In the best case, the volume of energy transmitted on the distribution network could be doubled without additional investments. If the alternative is to carry on with the present load rate, we may assume that the load control would prevent an additional cost of 815 M€/a, if the annual amount of energy were double the present amount, that is, 104 TWh. The highest theoretically possible cost benefit for the national economy would thus be approx. 8 €/MWh, that is, 0.8 cent/kWh. Here, it is emphasised that if the loads were controlled by optimising the use of the distribution network capacity as described above, the potential for market-based demand response would be lost. Therefore, it is essential to aim at a total optimisation where a compromise is reached between the benefits of the generation and the network.

A 3.2.4 Legislation regulating the tariff scheme

Laws and regulations that affect the selection of the tariff scheme include EU directives, the Finnish Electricity Market Act (386/1995), *Laki energiamarkkinoilla toimivien yritysten energiatehokkuuspalveluista* (1211/2009) (Act on energy efficiency services of enterprises operating in the energy market) and *Valtioneuvoston asetus sähköntoimitusten selvityksestä ja mittauksesta* (66/2009) (Government Decree on determination of electricity supply and metering).

According to Article 10 of 2006/32/EC

“Member States shall ensure the removal of those incentives in transmission and distribution tariffs that unnecessarily increase the volume of distributed or transmitted energy. In this respect, in accordance with Article 3(2) of Directive 2003/54/EC and with Article 3(2) of Directive 2003/55/EC, Member States may impose public service obligations relating to energy efficiency on undertakings operating in the electricity and gas sectors respectively.”

At present, “a Proposal for a Directive of the European Parliament and Council on energy efficiency and amending and subsequently repealing directives 2004/8/EC and 2006/32/EC” is still under discussion, and thus, changes in the directive may take place. This report applies the Proposal of 22 June 2011.

Item 4 of Article 12 has remained similar to Article 10 of the directive in force, and thus, no changes have been made in this respect to the requirements of the proposal for the directive.

Furthermore, Annex XI “Energy efficiency criteria for energy network regulation and for network tariffs set or approved by energy regulatory authorities” of the above-mentioned proposal for the directive provides more detailed regulations on network tariffs:

1. *Network tariffs shall accurately reflect electricity and cost savings in networks achieved from demand side and demand response measures and distributed generation, including savings from lowering the cost of delivery or of network investment and a more optimal operation of the network.*
2. *Network regulation and tariffs shall allow network operators to offer system services and system tariffs for demand response measures, demand management and distributed generation on organised electricity markets, in particular:*
 - a) *the shifting of the load from peak to off-peak times by final customers taking into account the availability of renewable energy, energy from cogeneration and distributed generation;*
 - b) *energy savings from demand response of distributed consumers by integrators;*
 - c) *demand reduction from energy efficiency measures undertaken by energy service companies and ESCOs;*
 - d) *the connection and dispatch of generation sources at lower voltage levels;*
 - e) *the connection of generation sources from closer location to the consumption; and*
 - f) *the storage of energy.*

For the purposes of this provision the term "organised electricity markets" shall include over-the-counter markets and electricity exchanges for trading energy, capacity, balancing and ancillary services in all timeframes, including forward, day-ahead and intra-day markets.

3. *Network tariffs shall be available that support dynamic pricing for demand response measures by final customers, including:*
 - a) *time-of-use tariffs;*
 - b) *critical peak pricing;*
 - c) *real time pricing; and*
 - d) *peak time rebates.*

Based on the above, we may state that no obvious inconsistencies were detected in the present directive or the proposal for the directive that would prevent the implementation of the tariff scheme discussed in this report.

In the Finnish legislation, the key regulation concerning the tariffs is Section 14 of the Electricity Market Act (386/1995):

The sale prices and terms of the system services and the criteria according to which they are determined shall be equitable and non-discriminatory to all system users. Exceptions to them may only be made on special grounds.

The pricing of system services shall be reasonable.

The pricing of system services must not present any unfounded terms or restrictions obviously limiting competition within the electricity trade. However, the pricing shall take account of any terms needed for reliable

operation and efficiency of the electricity system as well as the costs and benefits arisen by the connection of an electricity generation installation to a system.

Furthermore, Section 15 stipulates on spot pricing:

The system operator shall, for its own part, create preconditions permitting the customer to conclude a contract on all system services with the system operator to whose system he is connected as subscriber.

The system operator shall, for its part, create preconditions permitting the customer to be granted the rights, in return for payment of the appropriate fees, to use from its connection point the electricity system of the entire country, foreign connections excluded (spot pricing).

Within a distribution system, the price of system services must not depend on where within the system operator's area of responsibility the customer is located geographically.

On demand, the Ministry can issue detailed regulations on the application of the principles of spot pricing.

Section 38 a of the Electricity Market Act states on the supervision of the system operator:

By its decision, the electricity market authority shall confirm the following terms of services and methods of pricing services before their take-up to be complied with by the system operator and the grid operator under the systems responsibility:

- (1) methods to determine the system operator's return on its system operations and the fees charged for the transmission service during the surveillance period;*
- (2) terms of the system operator's transmission service;*
- (3) terms and methods of the system operator's connection service to determine the fees charged from the connection;*
- (4) terms of the services under the systems responsibility of the grid operator subjected to the systems responsibility and methods to determine the fees charged from the services.*

The confirmation decision shall be based on the criteria laid down in chapters 3, 4 and 6 a and in Regulation (EC) No 1228/2003 of the European Parliament and of the Council on conditions for access to the network for cross-border exchanges in electricity. The decision confirming the pricing methods can order on the following:

- (1) valuation principles of capital bound to system operations;*
- (2) method of determining the approved return on the capital bound to system operations;*
- (3) methods of determining the result of the system operations and the correction of the income statement and balance sheet required by them;*
- (4) target encouraging improvement of the efficiency of the system operations and the method of determining it, as well as a the method to apply the target in pricing;*
- (5) the method of determining the pricing structure, if the method of determination is necessary for providing access to the system or to implement an international obligation binding on Finland or if the method of determination is related to pricing of services under the systems responsibility.*

The confirmation decision, which is applied to the methods referred to in subsection 1(1), is valid during a four-year surveillance period. If the system operator has started its operations while the surveillance period applied to other system operators has not yet run out, the confirmation decision referred to in paragraph 1 of subsection 1 is, however, valid until the end of this surveillance period. The other decisions referred to in subsection 1 remain in force until further notice or, for a special reason, during the period laid down in the decision.

In the Act, it is stated that “the decision confirming the pricing method can order on the method of determining the pricing structure”; however, this is not requested from the surveillance authority. Section 1 of the Electricity Market Act states on energy efficiency that

Undertakings operating in the electricity market are responsible, for example, for providing their customers with services relating to the supply of electricity and for promoting electricity efficiency and conservation in their own business operations as well as in those of their customers.

However, unlike the directive 2006/32/EC, which states that there shall not be such incentives in transmission and distribution tariffs that unnecessarily increase the volume of distributed energy, the present legislation on the electricity market does not include any direct requirement on this kind. Currently, the regulatory model for the electricity distribution business monitors the reasonableness of the DSO’s return on capital, in addition to which limits are set on the amount of network asset depreciations and operative costs. Thus, in practice, the regulatory model sets the limits on the turnover of the DSOs, but does not take stance on the pricing structure.

The Act on energy efficiency services of enterprises operating in the energy market (1211/2009) stipulates an obligation for enterprises operating in the energy market to promote their customers’ electricity efficiency and conservation in their operations. The Act is applied to enterprises that sell or deliver electricity or district heating, district cooling or fuel. In practice, the Act sets requirements concerning electricity billing mainly for the electricity retailer; the act states that the retailer shall bill the electricity based on energy consumption at least three times a year. In addition, the retailer shall provide the end-user with a report of his/her energy consumption.

From the perspective of this research project, Chapter 6 of the Government Decree on determination of electricity supply and metering (66/2009)² is of practical relevance, as it determines the minimum requirements for the metering of electricity supply:

Section 4:

The metering of electricity consumption and small-scale electricity generation shall be based on hourly metering and remote reading of the metering equipment (obligation of hourly metering).

Section 5:

² Unofficial translation; the decree available only in Finnish and Swedish

The hourly metering equipment installed at the site of electricity use and the distribution system operator's information system processing the metering data shall have at least the following characteristics:

- 1) the data recorded by the metering equipment shall be remotely readable from the memory of the metering equipment through a data transmission network (remote reading feature);*
- 2) the metering equipment shall record the starting and ending points of the de-energised periods the duration of which exceeds three minutes;*
- 3) the metering equipment shall be capable of receiving and executing or forwarding load control commands sent through the data transmission network;*
- 4) the metering data and the data concerning the de-energised periods shall be stored in the distribution system operator's information system that handles the metering data; the hourly metering data shall be stored in this information system at least for six years and the data on the de-energised periods at least for two years;*
- 5) the data protection of the metering equipment and of the distribution system operator's information system handling the metering data shall be secured appropriately.*

The distribution network operator must offer hourly metering equipment for the customer's use, including a standardised connection for real-time monitoring of electricity consumption, if the customer places a separate order for such equipment.

In addition, the decree lays down a transition period such that at least 80 % of the consumption sites shall meet the above conditions by the end of 2013. Based on the legislation presented above, we may assume that in the future there will be meters in use that meter the hourly mean powers and are read once a day. This is the technical boundary condition applied also to the tariff alternatives considered in this report.

Furthermore, according to Section 1 of Chapter 7 of the above-mentioned decree

The distribution system operator shall offer metering services in accordance with the general time differentiation to the customers within its area of responsibility.

Metering services in accordance with the general time differentiation include:

- 1) metering service based on hourly metering;*
- 2) metering service for a flat rate tariff;*
- 3) metering service for a two-rate tariff (day/night);*
- 4) metering service for a seasonal tariff (winter weekday and other energy).*

Thus, the decree obliges to offer the above-described metering services. In practice, the present distribution tariffs follow the above division of metering services; however, this division is not required of the distribution charges, but it applies only to the metering services.

The objective of the Energy Services Directive (2006/32/EC)³ and the energy efficiency agreements adopted in accordance with it is to reduce energy use from the level of 2001–2005 by 9 % by 2016. There is an energy services action plan for the enterprises operating in electricity transmission and distribution and district heating; 91 enterprises had joined the plan by 26 January 2012. A directive target of the energy sector is to take measures that lead to a 150 GWh saving of electricity in the electricity transmission and distribution losses and in the electricity consumption of generation and transmission of district heat, and a 150 GWh saving in distribution losses of district heat and fuel consumption in separate generation of heat by 2016 compared with the present level without the above measures. Again, the target of the companies that have joined the agreement is to reduce their energy use at least by 5 %. Furthermore, the target of the companies that have signed up to the agreement is, together with their customers, to implement measures that promote the efficiency of the energy end use, and thereby, reaching of the energy savings targets (Energy Efficiency Agreements). Hence, reduction of losses, which is achieved for instance by cutting of the peak powers, is vital also for reaching the energy efficiency targets.

A 3.3 Current tariff schemes and their reform needs

The distribution tariffs of small-scale consumers in Finland typically comprise a fixed charge, which depends on the size of the main fuse, and an energy rate, which may vary between times of the day and seasons. Demand-based tariffs instead are intended for larger customers. Hence, the time dynamics of the small-scale consumer tariffs is mainly limited to the two-rate tariff, and the power taken at the connection point is limited only by the main fuse. Thus, the financial incentives for the temporal optimisation of electricity use are limited.

According to a survey by the Energy Market Authority (EMA 2010a), the proportion of the fixed charge in the tariffs has increased significantly over the past ten years, which for its part indicates needs for reforms in the tariff scheme. Table A-4 and Figure A-15 present the results of the survey considering the proportions of fixed and variable costs in the electricity distribution tariffs for typical end-users:

- K1, Flat, no electric sauna heater, main fuse 1 x 25 A, electricity consumption 2 000 kWh/yr
- K2, Detached house, no electric heating, electric sauna heater, main fuse 3 x 25 A, electricity consumption 5 000 kWh/ yr

³ Directive 2006/32/EC of the European Parliament and of the Council of 5 April 2006 on energy end-use efficiency and energy services.

- L1, Detached house, direct electric heating, main fuse 3 x 25 A, electricity consumption 18 000 kWh/ yr
- L2, Detached house, partly accumulating electric heating, main fuse 3 x 25 A, electricity consumption 20 000 kWh/ yr
- T1, Small-scale industry, power demand 75 kW, electricity consumption 150 000 kWh/ yr

The reference material in the survey comprises tariffs including VAT but excluding the electricity tax and the security-of-supply fee.

Table A-4: Proportion of the fixed and variable tariff components in the distribution tariffs of different types of consumers in 2000 and 2010 (EMA 2010a).

Type of consumer	Fixed		Variable	
	1/2000	1/2010	1/2000	1/2010
K1	42.4 %	58.2 %	57.6 %	41.8 %
K2	31.1 %	43.4 %	68.9 %	56.6 %
L1	26.0 %	34.9 %	74.0 %	65.1 %
L2	28.6 %	34.9 %	71.4 %	65.1 %
T1	24.6 %	24.6 %	75.4 %	75.4 %

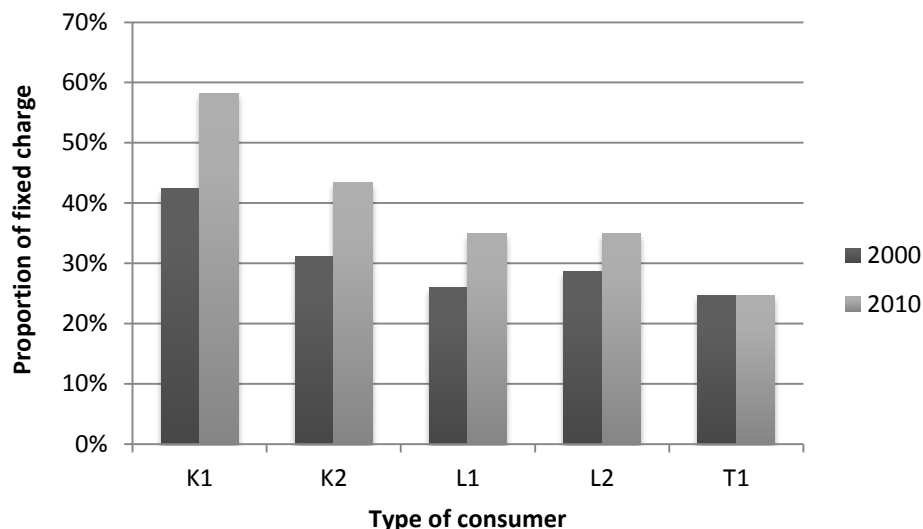

Figure A-15: Proportion of fixed charge in the distribution tariffs of different types of consumers (based on EMA 2010a).

The above figure shows that the proportion of the fixed tariff component has increased for all types of consumers except for industrial customers. Increasing the proportion of the fixed tariff component enhances the predictability of the distribution revenues, because in addition to the changing trends in the electricity consumption habits, the volume of transmitted energy is significantly influenced by the outdoor temperature. The above results are based on data for 2010, and a similar tendency has continued ever since; that is, the proportion of the fixed tariff component has increased further.

However, the proportions of the variable and fixed tariff components vary between DSOs, as shown in Figure A-16, which illustrates the standing charges and energy rates in typical flat rate distribution tariffs (for a 3x25 A main fuse) by DSOs based on statistics provided by the Energy Market Authority.

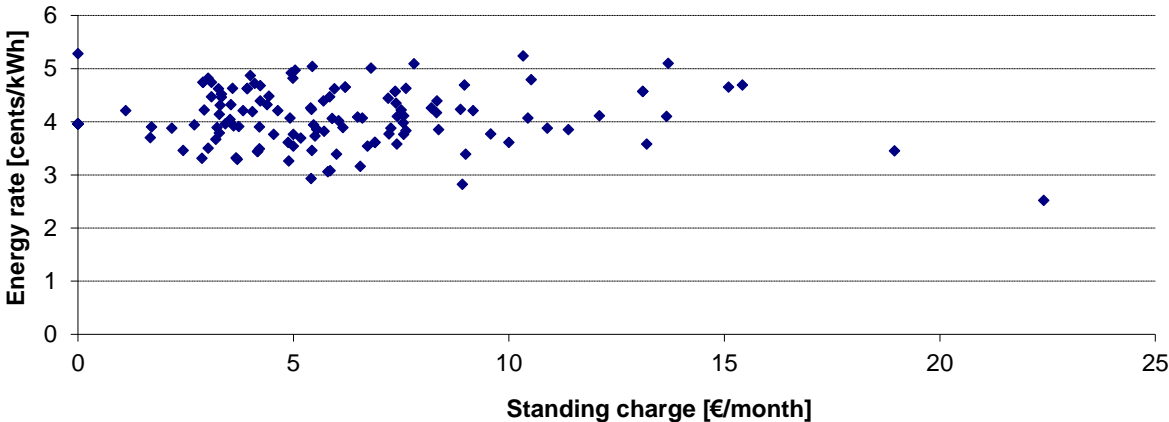

Figure A-16: Flat rate distribution tariffs of Finnish distribution system operators for a main fuse of 3x25 A (based on statistics of the Energy Market Authority).

A 3.3.1 Incentives of the tariff scheme

In the present tariffs, the flat rate tariff consists of a fixed standing charge (€/month) and an energy rate (cent/kWh), which is constant regardless of the time of use. The fixed monthly charge is usually based on the size of the main fuse, which in itself promotes the optimal dimensioning of the connection point. In practice, the power is limited only by the size of the main fuse, which is most typically 3x25 A. The energy component, again, encourages reduction of the total consumption of energy; however, its proportion has decreased in the 2000s, as stated above, which has weakened the above-described incentive effect.

The two-rate tariff similarly comprises a fixed standing charge, which depends on the size of the main fuse, and an energy rate, which is lower in the night-time (usually from 10 p.m. to 7 a.m.). The incentive effects of this tariff are otherwise similar to the flat rate tariff, but the tariff also includes an incentive to schedule the electricity use to the night-time whenever possible. In practice, this tariff type is used in connection with accumulating electric heating. The target of the tariff is to balance loads by shifting the electricity use to the night-time, when electricity is typically used least. However, the control does not monitor the state and needs of the electric power system, but numerous boilers that are simultaneously switched on may cause problems both in the distribution system and in the national power balance.

Considering the present tariff schemes, we may state that they encourage reduction of energy use, although the proportion of the fixed component has increased over the years. However, there are hardly any incentives for the target that is most vital for the distribution system, that is, the reduction of peak power.

A 3.3.2 Cost reflectivity of the present tariffs

As shown in Chapter A 3-2, a majority of the costs of a DSO are either fixed ones or depend on power, while only a minority depend on the volume of energy transmitted. Although the proportion of the fixed tariff component has increased, the energy-based tariff component still plays a key role in the revenue stream. Thus, the present tariffs do not correspond very well with the cost structure of DSOs. Moreover, in the present tariff scheme, the charges are not necessarily allocated to the customers by the matching principle, as will be illustrated below.

Figure A-17 and Figure A-18 present an annual duration curve for two actual end-customers. Both the customers have a 3x25 A main use, and their billing is based on a two-rate time-of-day tariff.

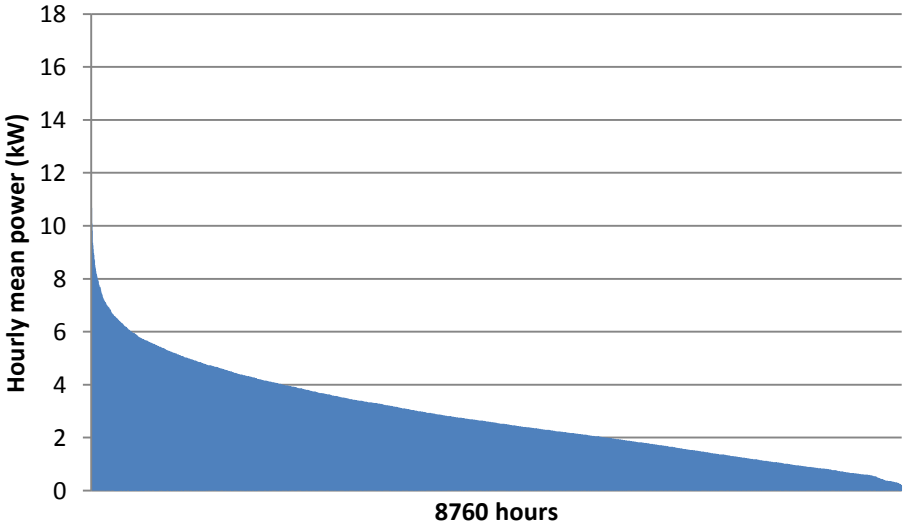

Figure A-17: Duration curve for the electricity consumption of customer A; the annual energy is 24.9 MWh and the peak power 124 KW.

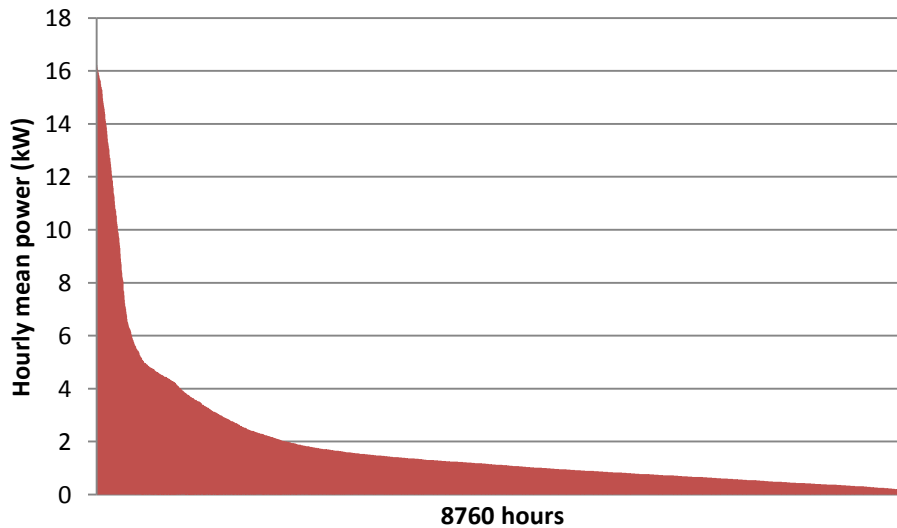

Figure A-18: Duration curve for the electricity consumption of customer B; the annual energy is 16.1 MWh and the peak power 16.7 KW.

As the network dimensioning is based on peak power, customer B produces a higher cost for the DSO than customer A. If the distribution pricing is based on transmitted energy, customer A will, however, pay a higher distribution charge than customer B. In other words, costs are not correctly allocated, but the customer producing a lower cost pays a higher distribution charge. If the proportions of fixed and variable tariff component are equal in the DSO's tariffs, customer A will pay a distribution charge that is about one-quarter higher than the charge of customer B.

A 3.3.3 Change trends in electricity use

Significant changes have taken and will take place in the volume of transmitted energy and power demand, which have an impact on the revenue and costs of the DSOs. Figure A-19 illustrates the effect of different actions on the power and energy as discussed in the workshop held in 2011. The workshop comprised researchers and representatives from DSOs and the Finnish Energy Industries, 22 persons altogether. Naturally, the effects are case specific, and thus, the figure only presents the experts' average estimates of the direction and magnitude of these changes.

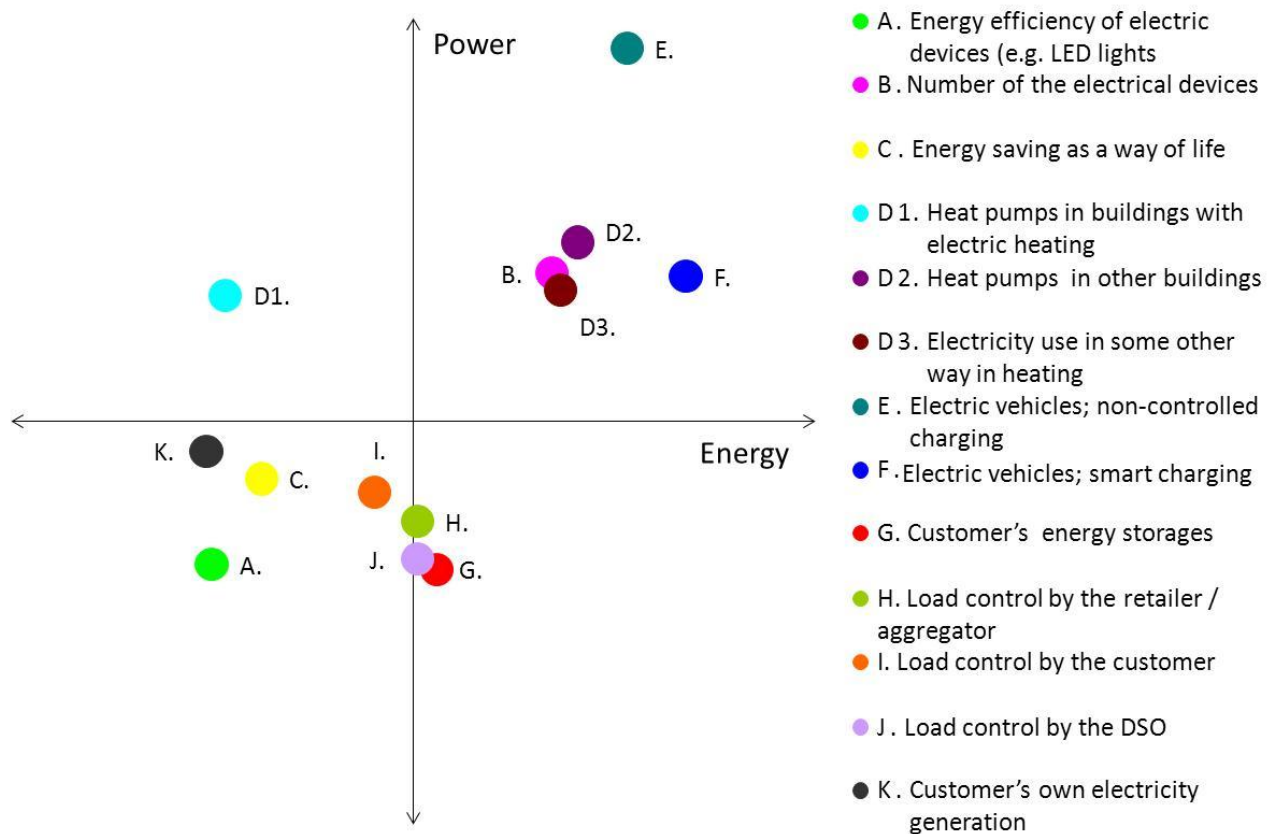

Figure A-19: Effects of different actions on the power and energy transmitted on the distribution network.

The actions that reduce the volume of transmitted energy and either increase or only slightly decrease the power demand are most problematic with respect to the present tariff system, which is chiefly based on transmitted energy. In particular, heat pumps in buildings with electric heating and customers' own electricity generation are problematic in this respect. For instance, it has been estimated that heat pumps will reduce the amount of annual transmitted energy by 11 % by 2020 in the operating area of a single distribution system operator, while the peak powers remain unchanged. If the tariff scheme remained in its present form, this would reduce the annual turnover by 5 %, whereas this development would not have an impact on the costs of the DSO. In the scenario of the highest impact, the volume of energy transmitted would decrease by 25 %, which, in turn, would decrease the annual turnover by 12 % (Tuunanen 2009). Consequently, the revenues would not correspond with the costs, and thus, the unit prices would have to be raised if the present tariff scheme were kept in force. Here, it is worth pointing out that heat pumps, similarly as the other actions in the figure, improve energy efficiency, and their adoption should be encouraged.

In general, we may state that energy saving and promotion of energy efficiency are targets to the adoption of which the customers should be motivated. However, at the same time, with the current tariff scheme, these actions have a negative impact on the economy of the distribution system operator, and they make the tariff scheme less cost reflective. Thus, considering both the revenue stream and the incentive aspects of the tariffs, the present tariff

schemes have to be developed to better correspond with the changing operating environment. In the next chapter, alternative tariff schemes are introduced.

A 3.4 Alternative tariff schemes

As shown above, the reform needs are evident in the present tariff scheme. In principle, the pricing of electricity distribution can be arranged in multiple ways. Bearing in mind the basic requirements for the tariff scheme, such as spot pricing, cost reflectivity and intelligibility, the alternatives are, in practice, narrowed down to a few schemes that can be applied either separately or combined. In the following sections, a few alternative tariff schemes are introduced, and their features are compared with the above-presented requirements and boundary conditions.

A 3.4.1 Fixed monthly charge

The principle of this tariff scheme is that the energy component is removed from the present tariff scheme, and thus, the tariff will only include a fixed monthly charge that is based on the size of the main fuse; the charge will of course be higher than the present one, as the turnover of the DSO is assumed to remain unchanged. For a customer, a distribution tariff of this kind is simple; for the DSO, the revenue stream is predictable, and, to some extent, cost reflective. The tariff would not produce contradictory incentives with the retail tariff, and would allow market-based demand response. Considering the network effects, the only incentive provided by the distribution tariff would be related to the optimisation of the main fuse size. However, the options are limited (for small-scale customers, typical alternatives are 3x25 A and 3x35 A). Thus, the peak power taken from the network is only limited by the main fuse, and the tariff does not include any other incentives for the optimisation of power consumption. Hence, only the retail tariff stimulates the efficiency of energy use.

A recent trend has been to increase the proportion of the fixed tariff component, as was stated above. An ultimate alternative of this development trend would be to have a fixed standing charge only, in which case the energy component would be removed altogether. Having only a fixed charge would thus guarantee predictable and stable transmission revenues for the DSO also in the changing operating environment. In a tariff scheme of this kind, the customers' opportunities to affect their electricity bills are practically non-existent, and the tariff scheme would not encourage energy efficient consumption of electricity. Thus, we may conclude that a tariff structure comprising a fixed component only would not meet the above criteria.

A 3.4.2 Energy rate

A trend opposite to the previous one is the course of development from the present tariff scheme to a tariff component that is based solely on energy. However, in practice, the trend has been quite the opposite, which, for one, is an indicator of the problems of the energy-based pricing from the DSO's perspective. As it was stated above, only a minority of the costs of the DSO depend on the volume of energy transmitted, and thus, the cost reflectivity of the energy-based tariff would be lower than that of the present tariff (fixed charge and energy component). In addition, the predictability of the DSO revenue would decrease significantly, as the transmission revenues are directly dependent on the volume of energy transmitted. In

that case, the variation in the outdoor temperature would have a higher impact on the revenues than at present.

An energy-based distribution tariff would strongly encourage the end-customers to reduce their energy consumption, which is naturally further supported by the electricity retail tariff. However, an energy-based tariff does not include any incentives to reduce the peak power, and thus, a reduction in energy consumption does not necessarily decrease the costs of the DSO. Consequently, we may state that the incentive effects or the cost reflectivity of the distribution tariff based solely on energy are not as good as anticipated.

A 3.4.3 Dynamic energy tariff

A development option that would encourage the customers to optimise their energy consumption into a direction that is optimal from the viewpoint of the distribution system is a dynamic energy tariff, in which the price of transmitted energy (cent/kWh) would vary according to the time of use. At present, a similar model is found in the two-rate tariff, where the energy rate is lower in the night-time. In this case, however, there are only two time and price levels in use, although the number of levels can, in principle, be significantly higher. When in the near future all the end-customers will have remotely read meters, the energy distribution charge could vary more dynamically according to the time of use, as illustrated in the simplified example in Figure A-20 Simplified example of a dynamic energy tariff. Figure A-20.

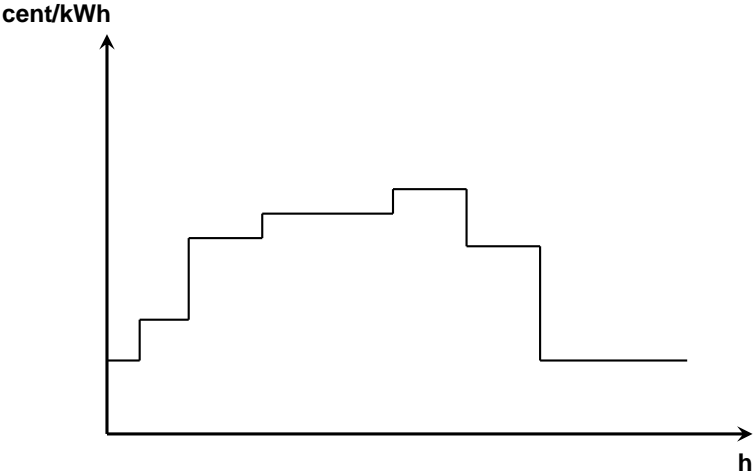

Figure A-20 Simplified example of a dynamic energy tariff.

In this tariff model, the price could be stepped so that the price would be highest at the instants when the network load is at highest, and vice versa. The time steps could be constant for every day, and differentiated between weekdays, Saturdays and Sundays, or they could vary so that the prices would be given in advance for instance on the previous day.

In a tariff structure of this kind, however, problems could arise both for the customers and the distribution system operator. First, the load behaviour varies significantly between different customers; the load peaks of domestic customers occur in the evening, while at workplaces

the electricity consumption is highest during the working hours. Thus, the time structure of a pricing scheme that would effectively balance the loads on the network should be based either on a single feeder or even on the supply area of a single distribution transformer. This would lead to different prices in different supply areas of the DSO, which is unambiguously prohibited by the Electricity Market Act. Using several price steps, together with a possible variation of inexpensive and expensive hours, would make the system complicated for the customers. Moreover, the tariff structure could produce contradictory incentives between the electricity retail and distribution, if the expensive and inexpensive hours for the distribution charge and the market price occurred at different times. In that case, the market-based demand response and the pricing of electricity distribution would steer the consumption in opposite directions. The suggested tariff structure would become too complicated, and its incentive effects would be ambiguous for the customer. For a DSO, it would also be uncertain whether the targets set for the tariff scheme could be met.

A 3.4.4 Power-based pricing scheme

In the power-based pricing, the distribution charge is based on the peak power taken from the grid (in practice, the highest hourly mean power) over a certain time period, or on a certain subscribed capacity agreed upon with the DSO. Power-based pricing is nowadays common for large-scale customers, whereas it is not used for small-scale customers. In Sweden, for instance Sollentuna Energi has introduced power-based pricing for all of its customers. In Sollentuna's network tariffs, there are a standing charge that depends on the main fuse size (e.g. 1 200 Swedish kronor/a for a 25 A fuse without taxes) and power charge (from November to February 69.60 kronor/kW, month and from April to October 34.80 kronor/kW, month excluding taxes). The power charged to the customer is based on hourly powers on weekdays between 7 a.m. and 7 p.m., from which a mean value of three peak hourly powers is calculated on a monthly basis (www.sollentunaenergi.se).

In practice, the power tariff is cost reflective for the DSO, because the pricing principle is the same as the key cost basis of the electricity distribution. Also the predictability of transmission revenues is higher than in the energy-based pricing, as for instance the variations in the annual mean temperature have a significantly lower impact on the annual peak powers than on the volume of transmitted energy. Similarly, the structural changes in the electricity end-use, such as installation of a heat pump for space heating, have a lower effect on power than on energy.

The suggested pricing scheme would steer the customers to reduce their peak powers, which would promote the energy efficiency of electricity distribution. Reduction in the overall energy consumption is encouraged by the energy rate of the retail tariff as well as by the electricity tax, and also the distribution charge may involve an energy component in addition to the power component. This, however, complicates the tariff scheme further. In principle, the price of power may vary by the time of use, either so that the powers at low-load hours are not taken into account when determining the peak power used as the pricing basis, or so that the price of the peak power occurring at the peak load hour is higher. This, however, may lead to similar problems as described above for the dynamic energy tariff. The basis for pricing can be either active power (kW) or current (A). The benefit of the latter is that it also includes

reactive power, but on the other hand, the power demand is usually given in watts in electric devices, and it is thus easier to understand as a unit of measurement. In practice, in power-based pricing, the customers should be able to follow and limit their power demand, either manually or automatically, for instance by alternation. Power-based pricing may involve different pricing models; these are for instance sliding power pricing and power band pricing, which are introduced and discussed in the following.

In the sliding power pricing, the customer could be charged for instance according to the highest metered hourly mean power of one year based on the AMR data. The hourly powers applied to the customer billing would be metered for a period of one year. The bill would be the same for every month for a year. For instance, a household with the highest hourly power of 10.0 kW would pay a distribution charge of 50 €, if the kW price were 5 €. The annual distribution charge would thus be 600 €. Variation could occur in the distribution charges in the sliding power pricing scheme between years, even though the amount of variation is lower in power than in energy. Nevertheless, the variation in annual power would degrade the predictability of the DSO's turnover. In particular, fluctuations in the power demand of customers with electric heating can be quite significant. The highest hourly power of a customer with electric heating may vary by more than 3 kW between years. Based on the customers' hourly metering data over the few past years, the values between years may vary by 2 kW even for the 30th highest hourly power for a customer. Now, we assume that the DSO has decided to determine the kW price to be 5 € in this pricing scheme, and the basis of charging is the mean value for the 30th highest hourly power. If there is a 2 kW difference between two years in the charging of hours used in the calculation, this will mean $2\text{ kW} \times 5 \text{ €/kW}$, month \times 12 months = 120 €, year in the DSO's turnover and the customer's distribution bill.

Variation may thus take place between years, which is not desirable either for the distribution system operator or the customer. Figure A-21 shows DSOs' total variations in power between years.

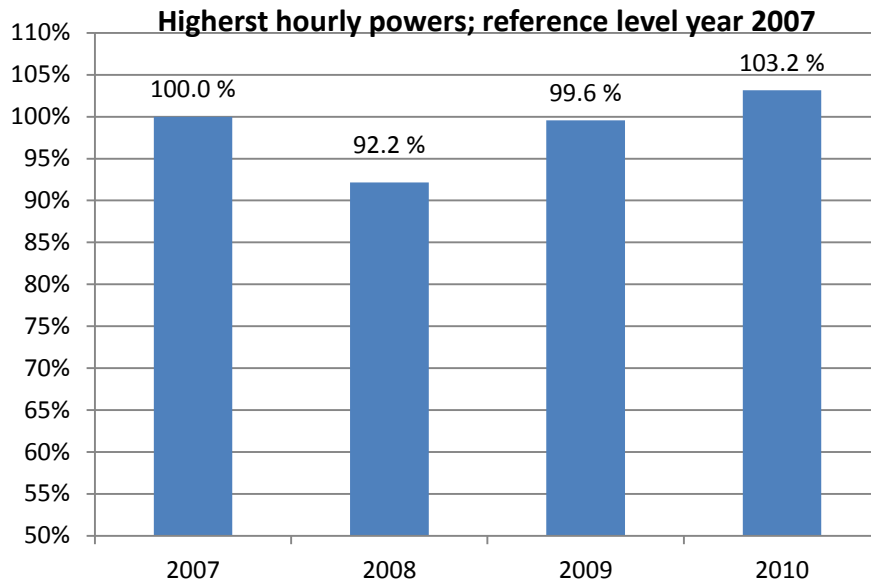

Figure A-21: Sums of the highest hourly powers for years 2007–2010. Year 2007 is used as the reference level (EMA 2010b).

Another power-based alternative is a power band pricing scheme based on current or power. For a DSO, a benefit of power band pricing is the same power band and power band charge for the whole year and an almost constant turnover in different years. Power band pricing is discussed in more detail in the following chapter.

A 3.5 Power band

Power band is a distribution pricing scheme developed from power-based pricing. It seems a viable novel solution to distribution pricing, and therefore, it has been studied in a larger scale. For customers, DSOs and the electricity market as a whole, power band pricing involves various positive features. For instance, a power band would promote, better than the sliding power pricing scheme, the targets of a distribution network turnover that would be steady at an annual level and the equal monthly distribution charges of customers. Introduction of power band pricing would not require any new technology or large investments. The on-going installation of remotely read electricity meters, however, has to be accomplished prior to the transfer to this pricing scheme. A further benefit of the power band is the low dependency of distribution charges on the outdoor temperature. This, again, has an influence on the turnover of the DSO and the distribution charges of customers with electric heating. The AMR meters in smart grids together with various control systems may enable new functionalities in the electric power systems, but also produce new development needs in distribution pricing. In this respect, the power band could be a viable alternative because it is flexible and cost reflective.

A 3.6 Introduction of power band

The concept of power band is familiar to the public through internet broadband. In the context of electricity distribution, the concept would mean that a customer would subscribe to the desired subscribed power, in other words, electricity distribution capacity, provided by the DSO. In practice, this would correspond to the practice of subscribing to a broadband service of a mobile operator. In distribution pricing, the transition to the power band pricing could thus make the customer's electricity bill more intelligible. However, the intelligibility of power band pricing is not addressed in more detail in this study, and thus, the issue should be studied further in the future.

The customers' subscribed power could chiefly be the transmission capacity required by the customer, that is, the mean power of the peak hour. Considering the electricity distribution capacity, some other options have been studied in addition to the highest hourly mean power; however, it has been found to be clearly the best one for the purpose. The price of subscribed power would be determined based on the network operation costs, that is, the regulated revenues and volumes of subscribed power. Power-based pricing would encourage the customers to reduce their subscribed power, and thus, the loads could be balanced more evenly. If the pricing were based on power, the customers would pay for the proportion of the total network capacity they have used. The average network tariffs of customers would not change; in other words, the revenues of the DSO would remain constant in the new situation. Similarly, the average proportion of the distribution fee in the total price of electricity would remain unchanged.

A customer's power band would be determined based on the highest metered hourly mean power of the year; in other words, in practice according to the customer's hourly peak power. For instance, for the customer in Figure A-22, the highest hourly power would be about 14 kW. If the customer were charged based on the highest hourly power, the customer's power band would be 14 kW. The customer would pay a fixed monthly charge for the power band every month of the year.

In principle, we may think that a customer is already billed based on a power band scheme. The fixed charge in the DSO's distribution tariff is usually based on the customer's main fuse size. The domestic customer in Figure A-22 has a main fuse of 3x25 A, and thus, the largest power band measured as an hourly power would be approx. 17 kW (indicated by the red line in the figure). The customer could consume a significantly larger amount of electricity in an hour, that is, for the whole band width with the same standing charge; however, the proportion of the energy rate in the retail and distribution tariffs and the electricity tax would limit the excessive use of energy. Now, the fuse size is the only factor that limits the peak power; yet, for small-scale customers, it has almost no incentive to reduce power consumption.

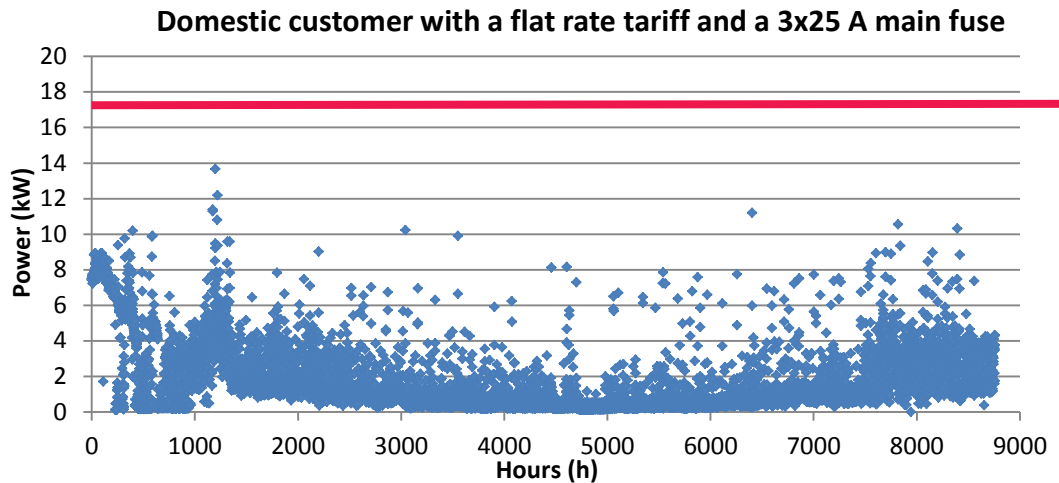

Figure A-22: Hourly AMR metering data of a domestic customer for 2011. The customer has a main fuse of 3x25 A and a flat rate electricity tariff in use. The customer’s highest hourly power is approx. 14 kW. The customer could use the whole power band of 17 kW limited by the main fuses (red line) with the present standing charge.

Hence, the present distribution pricing does not encourage reduction of power demand. The customer does not have an opportunity to affect the standing charge either, if the main fuse size of the customer is already as small as it can be. Despite this, the customers should have an incentive to reduce their peak power and thus affect the standing charge.

A fixed monthly charge may sometimes be somewhat challenging from the pricing point of view. Exceptional distribution pricing, for instance temporary electricity supply, may cause slight ambiguity in pricing. In power band pricing, this could be solved for instance by multiplying the annual distribution charge for a certain power band by the ratio of the days when temporary electricity supply is needed to the days of one year (365).

A 3.7 Pricing schemes and the unit of power band

A suitable pricing scheme that is in compliance with the laws and directives set for pricing should be established for the power band. Moreover, it should be applicable to different distribution system operators and customer types. In Finland, there are a large number of DSOs, and the pricing schemes and prices vary considerably between the operators. On the other hand, the networks of DSOs are very different, and thus, the distribution prices should not be compared between the companies.

In addition to the different operating environments of the DSOs, the customer distribution and the electric energy and power consumed by the customers vary significantly. This can be illustrated by the flat rate distribution tariff that almost all DSOs offer for their customers. In the flat rate electricity tariff alone there are usually different categories for the main fuse size, such as 3x25 A or 3x63 A, into which the customer may fall. In addition to this, the same flat

rate distribution tariff group may include customers that live in blocks of flats and have low energy consumption, or small-scale industrial customers with a larger consumption of electricity. Hence, there is a significant amount of variation, which has to be taken into account when analysing the calculation results. If the issue is considered with respect to customers of a certain type, we will understand the reasons for this variation. Table A-5 shows the differences between individual customers within a customer group of similar type.

In the example group, the customers live in detached houses (DH) with electric heating (either accumulating, partly accumulating or direct electric heating). The table gives the electric energy consumption of one year, the peak power and the annual distribution charge according to the present pricing scheme and the peak operating time for these customers. There are 13 customers in the group, and their annual energies vary between 6.8 and 24.4 MWh. As we can see, the customers' annual consumption may vary considerably even among customers of similar type. The differences in annual energies are explained by different types of heating. Some customers have electric heating only, while some may have additional heating with wood or a heat pump. In addition, also the size of the building has an impact on the demand for heating. All the customers are charged at a two-rate time-of-use tariff. The differences in distribution charges are revealed by the energy consumption over time. For instance, the amount of distribution charge paid by the first customer is almost the same as that of the second customer, although he/she consumes 3.5 MWh less. The difference is explained by the fact that the consumption of the first customer takes place mainly in daytime when the price of energy is at highest and vice versa. In addition, Table 5.1 illustrates the differences in the measured highest hourly mean powers between the customers. For instance, the peak power of the last customer is less than 10 kW, although he/she consumes less energy and pays a higher distribution charge than the second last customer, the peak power of which is more than 10 kW.

Table A-5: Annual energies, peak powers and annual distribution charges according to the prevailing pricing scheme as well as the peak operating time for different customers living in detached houses (DH) with electric heating.

Customer type	Annual energy [kWh]	Peak power [kW]	Present distribution charge [€, a]	Peak operating time [h]
DH electric heating	6 834	3.56	472	1920
DH electric heating	10 339	4.63	515	2233
DH electric heating	11 586	8.71	502	1330
DH electric heating	11 789	4.12	533	2861
DH electric heating	12 130	8.43	475	1439
DH electric heating	12 197	6.06	509	2013
DH electric heating	14 810	9.07	653	1633
DH electric heating	15 061	7.83	551	1923
DH electric heating	16 534	7.51	678	2202
DH electric heating	16 923	7.30	702	2253
DH electric heating	17 094	7.82	821	2186
DH electric heating	20 712	10.77	693	1923
DH electric heating	24 467	9.43	907	2595

There are various alternatives available both for the distribution and power band pricing. The unit price may behave in different ways with respect to kW or amperes. Alternatives for power band prices could be for instance a unit price that decreases with the increasing power band, fixed price and increasing price. In addition to these, various step schemes can be developed for the power band, where the steps occur for instance at every ampere or 5 kW. In the power band scheme, suitable steps should be found for each band so that the monthly charge still increases as the band increases. This condition has to be met to ensure that customers have motivation to reduce their power band. On the other hand, the pricing scheme should not encourage the customers to subscribe to larger power bands, in which case they would not pursue the aim of reducing their power. Thus, a decreasing unit price is out of question. Alternatively, if the unit price were increasing along with an increasing band, the high band prices for large power bands would cause a problem. Hence, we may conclude that it is justified to apply a fixed price as the price for the power band. Consequently, the price

would be equal to all customers and encourage power saving. In addition, there would be a clear basis for the power band pricing and power optimisation of the customer power.

In most of the Finnish DSOs, the standing charge in the distribution pricing depends on the size of the main fuse; on the charge scale, the lowest standing charges are either for 1x25, 3x25 A or 3x35 A. Compared with the present distribution pricing, the steps in the power band pricing scheme should be significantly smaller. Quite a different approach is provided by an alternative where the bands occur in steps of one ampere. For a DSO, the transition from the present charge scale to a fine power band scale would be difficult and rigid to implement. In addition, the customers should have suitable devices to be able to meter their consumption on the fine power band scale. These would include at least a consumption display, home automation system or an online service provided by the DSO. Such devices, however, are possessed only by few customers. Thus, it is advisable to first define the steps for more than one unit, such as five units on the power band scale.

Yet another issue related to power-based pricing is whether the unit of pricing is amperes or kilowatts. Ampere is the unit of current, and amperes are familiar to customers because of the main fuse size applied in the present distribution pricing. Amperes would be practical and easy to use, as they would remove the need to charge for reactive power. If amperes were applied, the DSOs would have to modify their AMR data, which is given in kilowatts. On the other hand, amperes may be difficult for the customers to understand; it may be challenging to explain to a customer how one ampere (of consumption) is formed or how large an 'ampere band' the customer needs. In the case of kilowatts, this is easier as power ratings are usually given in different electric devices. Thus, the customers are able to consider their power consumption and requirements for the power band. For instance, a customer living in a flat may have a 6 kW electric sauna heater. The customer is probably able to comprehend that this is the minimum amount of power band he/she needs. At the same time, the efficiency of different electricity saving measures is clarified. For instance, if the customer has a device with a power of 2 kW, and he/she decides to invest in a new, similar device with a power of 1 kW, he/she probably understands the effect of the investment on the price of electricity distribution. A slight problem in the application of kilowatts is the separation of effective and reactive power. In the power-based pricing, the DSOs would like to apply separate pricing for active and reactive power; in particular, as the amount of reactive power is currently increasing for instance because of the increasing number of energy saving lamps. Nevertheless, for the customers, separate charges for active and reactive powers would be difficult to comprehend. In the kilowatt-based pricing scheme, the active and reactive power could be combined (apparent power), and the charging would be unified, comprising both price components. On the other hand, it is worth remembering that the present remote meters installed at customers are not typically able to meter active and reactive power separately, or amperes. Thus, it is justified to use kilowatts as the unit of pricing, and reactive power pricing is omitted from the considerations for the time being. However, the issue of reactive power should be addressed in more detail in the future studies.

The applicability of the power band scheme could be evaluated by considering the present distribution pricing scheme based on the size of the main fuse. If the issue is approached from the perspective of power band pricing, the domestic customers will nearly always order a

power band of 17 kW; the customers have no opportunity to affect this. Let us take a different approach and provide the customers with an opportunity to scale their power band down. Based on the above, it has been decided to apply kilowatts with a 5 kW power band scale as a basis for the power-based pricing in the calculations. In Table A-6, two different alternatives are given to show how the main fuses and their powers would correspond to the power band scale. On the left, there is a power band scale with 5 kW steps, and on the right with 3 kW steps. In principle, both the scales correspond well to the present main fuse sizes and thereby also to the standing charges. In Table A-6 on the right, the scale starts from 2 kW, which can be too low even for the smallest consumers. If the target is to use a fixed price as the unit price, a threshold charge should be included in the pricing. This threshold charge would be a minimum distribution charge to cover the fixed costs.

Table A-6: Alternative power band scales. The left-hand column has been used in the calculations. The right-hand column is based on the idea of determining the power bands in smaller steps.

Main fuse (A)	Power (kW)	Band (kW)	Main fuse (A)	Power (kW)	Band (kW)
		5			2
		10			5
25	17	15			8
		20			11
35	25	25			14
		30	25	17	17
50	35	35			20
		40			23
63	44	45	35	25	25
					29
					32
			50	35	35
					38
					41

It is difficult to determine a fixed price for the pricing of the power band, if the smallest band of the customer is really small. Therefore, a threshold charge is required, if the target is to collect a certain minimum sum to cover the fixed costs caused by the customer. Table A-7 lists the monthly and annual charges on a finer power band scale where the unit price is a fixed price of 2.5 €/kW, month.

The bands would continue by the same logic as far as required by the customers. Changes caused by the pricing scheme to the distribution pricing are calculated in steps of 5 kW. In the power band pricing scheme, the target is to improve the characteristics related to the distribution pricing, and thus, the purpose of the power band is not to impact on the construction of customer connections. Hence, the cross-sectional areas of low-voltage conductors and fuse sizes would remain unchanged. In other words, the size of a customer's main fuse, e.g. 3x25 A, will not be scaled down, even if the customer subscribes to a power band of 10 kW. However, if the powers transmitted on the network decrease, also the long-term investment costs of the DSO will decrease, which will show in the distribution prices in the long term.

Table A-7: Example of monthly and annual prices for power bands. The unit price €/kW is an approximate value.

BAND	PRICE	PRICE	PRICE
(kW)	(€/kW)	(€, month)	(€, a)
2	2.5	5	60
5	2.5	12.5	150
8	2.5	20	240
11	2.5	27.5	330
14	2.5	35	420
17	2.5	42.5	510
20	2.5	50	600
23	2.5	57.5	690
26	2.5	65	780
29	2.5	72.5	870
32	2.5	80	960
35	2.5	87.5	1050
38	2.5	95	1140
41	2.5	102.5	1230
44	2.5	110	1320
47	2.5	117.5	1410
50	2.5	125	1500

The calculations showed that the power band should first be introduced to replace the present standing charges. In that case, the tariff scheme will be similar to the present one (€/month + cent/kWh), but the standing charge would be determined based on the power band, and thus, a customer would have an incentive to reduce his/her power, and thereby a genuine opportunity to affect the amount of the standing charge. If the transition to the new pricing scheme were carried out this way, the non-recurring changes in the distribution price would remain minor.

The transition to this pricing scheme could be carried out in one year's time. Later, if the target is to increase the proportion of the power band in the distribution tariff, the proportion of the energy rate could be reduced and the proportion of the power band could be increased. It will take time to ensure that the changes are not too radical for an individual customer. The schedule for this phase could be approximately five years.

A 3.7.1 Excess usage of power band

Opinions vary on how the power band size of an individual customer should be determined. We may question whether the highest hourly power is an equitable basis for the determination of the power band, and whether a customer can be allowed to exceed his/her band a few times without additional costs. For the DSO, using the highest hourly power as a basis for the determination would be justified, as the dimensioning of the network is based on the highest powers on the network. From the customer's point of view, the highest consumed hourly power could also be a suitable basis for charging, as it would be based on actual consumption. A drawback is that the pricing scheme would be somewhat rigid. Considering the pricing, a more flexible option is that the customer is allowed to exceed the band for instance ten times. There are 8760 hours in a year, and hence, the tenth highest hourly power accounts only for 0.1 % of all the hours of the year. Events of excess usage of the power band are not very harmful to the network, as there is usually some flexibility involved in the present networks. From the customers' perspective and for the sake of flexibility of the power band pricing, it would be justified to allow a customer to exceed the band for instance 10, 30 or even 50 times a year.

At the moment, the customers' highest hourly power usually remains below the powers determined by the fuses. Sometimes the hourly powers may be somewhat higher than the powers limited by the fuses, because the fuses do not react to slight exceeding of the power limits. In the power band pricing scheme, significant exceeding of the power bands should not be possible, as the size of the main fuse should limit the customer's band in any case. For instance, a domestic customer's normal main fuse size is 3x25 A, which corresponds to 17 kW. Thus, in principle, the largest band that the customer could choose would be 17 kW. However, the powers above this would be limited by the fuses already. In addition, there are customers who, in principle, do not have an opportunity to choose too large power bands for themselves; such are for instance customers living in flats without an electric sauna. At customers of this kind, the largest current-using device is typically an electric stove, the power rating of which is usually about 3 kW. If we assume all other electric equipment to operate at the same time, the highest power still remains well below 10 kW.

On the other hand, a customer may also possess equipment that consumes a considerable amount of electric power compared with other devices. In that case, the customer may exceed the band without noticing when using all the electric equipment in an energy-inefficient manner at the same time. For domestic customers, a typical example is a sauna heater in a flat. However, excess usage events of this kind are not frequent, and they are usually minor. Thus, when changing over to power band pricing, significant exceedings of the power band will not take place, and the excess usage can be controlled somehow in practice. Obviously, the excess usage of the power band has to be observed.

In this context, in addition to the excess usage of the power band, it is worth our while to discuss the overdimensioning of power bands in brief. Overdimensioning of the power band would mean that a customer's actual consumption would be clearly below the subscribed power band, in which case the customer could well do with a smaller band. A customer, the power band of which is based on 6.9 kW (highest hourly mean power) serves here as an example: the customer could do well with a 10 kW band, but pays for a band of 15 kW instead. Naturally, situations of this kind should be avoided. If the customer showed no interest in monitoring the size of his/her power band, the DSO could take care of the problems related to overdimensioning. In a situation like this, the information systems of the DSO would handle the situation. By monitoring the hourly power used as the basis for billing, the information system could detect that the customer can do well with a band of 10 kW. In that case, the DSO would automatically scale the customer's band down. Thus, no harm would be done because of the oversized power bands. The same practice could be applied also to the selection of the power band in general: the DSO determines the power band, but the customer may change it and order another one. If the customer wants to have a smaller power band, he/she should have to pay for this. Subscribing to a larger power band instead would not cause extra costs. Changing over to a smaller band should be charged in order to prevent speculation on the band size and charges.

Let us return to the principles for determining the size of the power band. Based on the flexibility of the power band, we may consider that the customer's power band could be determined for instance based on the 10th highest hourly power. An advantage would be that the number of events of excess power band usage could, in principle, be estimated for a customer in advance. If some flexibility is included in the determination of the highest hourly power, the customer pricing could also be based on the mean value of the highest hours. The calculations have shown that the issue is of no significance to a customer group. Similarly, for an individual customer, the differences between these two methods are quite marginal. Thus, the question of whether the basis for billing is for instance the 30th highest hourly power or its mean value is relevant only for a marginal number of customers. In addition, for the DSOs, the method based on the mean value of the highest hourly powers would probably be more difficult to implement. The mean value does not bring any additional benefit, and it is thus excluded from the considerations.

Larger differences may occur between individual customers depending on whether the customer's band size is determined based on the highest hourly power or the 30th highest hourly power. The highest hourly powers of a customer may be a few kilowatts higher than the customer's other consumption in normal conditions (see Fig. 5.3). This may partly be explained by the fact that in the distribution pricing products there have been no incentives steering the customers' power consumption so far. In practice, the customers could have used their power capacity however they like within the limits set by their main fuses. Hence, it is likely that if the distribution pricing were based, if only partly, on the power consumed by the customers, the customers would start to pay more attention to their electricity consumption, and try to reduce their power use. The calculations seem to indicate that in our case, it is not very significant for the customer group whether the basis of billing is the hourly powers from the 30th highest power onwards; in other words, whether the basis of power band determination is the 30th or 50th highest hourly power. Changes may naturally take place, but

they are usually such that one customer benefits from the change in the pricing scheme while another loses an equal amount. Thus, the basis for the determination of the power band is limited so that the highest hourly power is applied to determine the customer's power band, and some events of excess power band usage are allowed.

A 3.7.1.1 Events of power band excess usage; power band pricing in the standing charge only

Applying the power band to the present standing charge may cause changes in the amount of the distribution charge for certain individual customers, and the distribution charge may increase for some customers in the transition period. However, it should be borne in mind that almost all customers will have an opportunity to change their power band to a smaller one and thereby affect their distribution charge. Therefore, when preparing the pricing scheme, special attention should be paid to the excess usage of the power band. If the power band were first applied to the standing charge only, the weight of excess usage would not have to be as high as when the power band forms the basis for the whole distribution pricing. The calculations have shown that in most cases, when comparing a suitable practice for the excess usage between customers, it occurs that the price sinks for one customer but rises for another.

First, when switching from the present distribution pricing scheme to the power band scheme in the standing charge, the determination of the power band could be based on the customer's highest metered hourly power of one year. This can be justified for instance by the fact that this would guarantee equal treatment of customers from the start. Another argument is that the practice applied to the excess power band usage would be unambiguous, which is probably highly important in the transition. If the charging is based on the highest hourly power of the previous year, it is likely that the number of events of excess power band usage is relatively low. This is illustrated by Figure A-23 and Figure A-24, which present the consumption curves for different years.

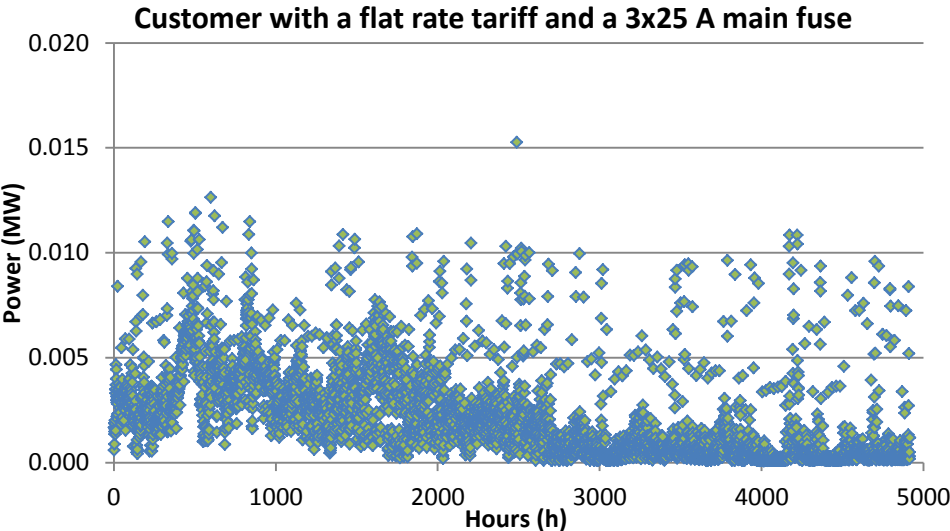

Figure A-23 Hourly AMR data of a domestic customer for approx. one year (2006). The main fuse is 3x25 A, and the customer is charged based on the flat rate distribution tariff. The highest hourly power is slightly above 15 kW.

In Figure A-23, the customer’s peak hourly power is about 15.5 kW, and thus, he/she should order a power band of 20 kW. The figure shows that there is no danger of exceeding the 20 kW band, and even if the band were 15 kW, exceeding of the band would be highly unlikely. However, the customer would have significant potential to cut the highest hourly power. In cases like this, the customer could nevertheless be provided with an opportunity to affect the size of the power band. The customer could check the size of his/her suitable power band for instance in an online service.

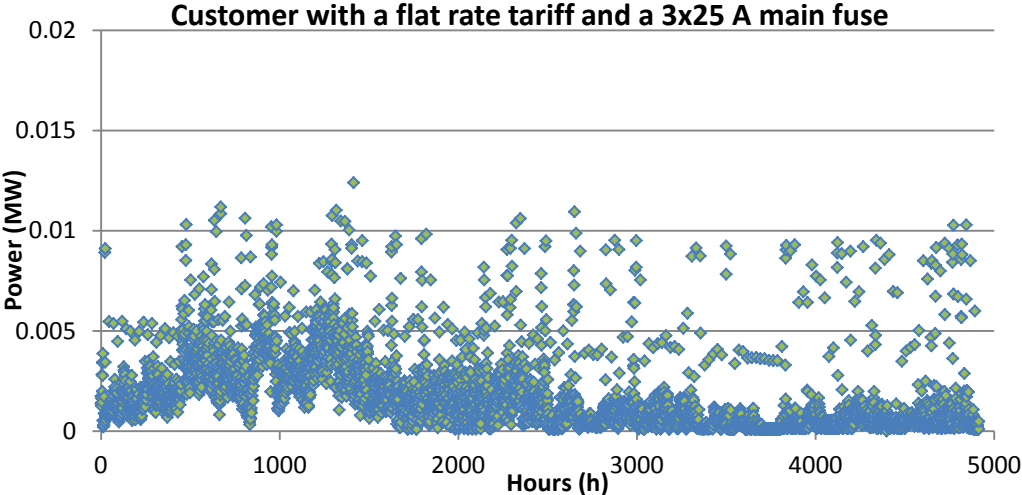

Figure A-24: Hourly AMR data of the domestic customer of Fig. 5.2, now for year 2007. The highest hourly power is slightly above 12 kW. The customer’s 10th highest hourly power is also above 10 kW, and thus, the power band of 15 kW would still hold.

If the customer’s power band were determined according to year 2007, (Figure A-24), his/her power band would be 15 kW based on the highest hourly power. No events of excess usage would probably occur in this case either. Instead, if the power band had been 10 kW, there would have been 15 events of excess usage. By cutting down his/her power consumption, the customer could well do with a 10 kW band.

The proportion of the standing charge is generally 10–60 % of the distribution charge. If power band pricing were applied only to the standing charge of the distribution charge and its proportion of the distribution charge were at least 50 %, the highest hourly power could be used as the basis in the determination of the power band. Customers at all power band steps should be allowed to exceed the band. The number of excess usage events could be same for all power band steps. A suitable number could be for instance ten excess usage events.

For the DSO, an advantage in changing over from the standing charge to the power band scheme is that it causes no risk to the company revenue. The DSO can control the revenue to be collected by determining the power band prices according to its targets. On the other hand, if the distribution pricing as a whole is based on power band pricing, the amount of power used in billing has to be reconsidered.

A 3.7.1.2 Excess power band usage; full power-band-based distribution pricing

If the distribution pricing were based fully on the power band and the highest hourly power consumed, it would cause significant changes in the electricity price to farmers, enterprises and small-scale industry. Let us consider an example of an agricultural consumer (farm) with main fuses of 3x63 A, corresponding to a power of 43 kW. The consumption curve of a customer of this kind is illustrated in Figure A-25. The customer's peak power is 33 kW and the customer has consumed 16.3 MWh of electricity during one year. Now, if the customer were charged according to the peak hourly power for the whole year, as it was assumed previously, the customer's electricity bill would increase considerably from the present level. At the moment, the customer's distribution charge is about 1 250 € without electricity tax, where the proportion of the standing charge is about 700 € and the energy rate is about 550 €. If the power band replaced only the standing charge in the distribution pricing, the customer's distribution charge would remain at the 35 kW band nearly the same as with the present pricing scheme.

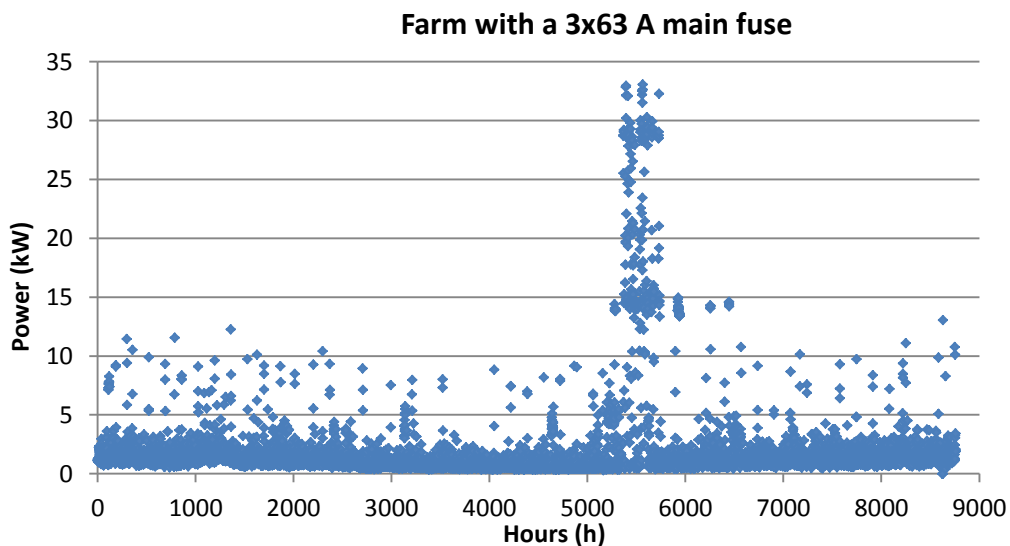

Figure A-25: Electricity consumption of an agricultural customer, showing a peak caused by grain drying in July–August compared with the normal consumption rates. In the figure, one month equals 730 hours.

However, problems would arise if the proportion of energy rate were decreased and the proportion of power band were increased. In that case, the power band prices should be increased equally for all bands. As a result, the example customer's price of the power band would be 2.5-fold; in other words, the agricultural customer's new distribution charge would be about 3 150 € a year. Thus, the events of excess power band usage should be treated differently in the case of a full-weight power band than when the power band is applied to the standing charge of the electricity distribution. The number of excess usage events should be taken into account, because the price of the power band would have a significantly higher weight in the price of electricity distribution.

For the example customer, a suitable power band would be 15 kW at the moment, when the period of grain drying in August is excluded from the analysis. With the power band pricing model, the customer’s distribution charge would be approx. 1000 €, in other words, it would be slightly lower than with the present pricing scheme. However, the events of excess power band usage cannot be neglected; if the customer had a 20 kW band, he/she would have exceeded it almost hundred times. As stated above, choosing a larger band for the customer is out of question, and thus, other solutions have to be sought. Here, we have at least two alternatives: either to allow the customer to exceed the power bands by different steps for the excess usage, or to charge the customer for the excess usage.

An example of the steps for the events of excess power band usage is given in Table A-8. The figures in the table indicate for instance that a customer with a 5 kW band would be allowed to exceed the subscribed band ten times. The events would be recorded automatically by the DSO, and the customer would not have to worry about them. In addition, this method would help in tracking exceptional customers from the customer group.

Table A-8: Example of the steps for events of excess power band usage. The figures are examples only.

POWER BAND (kW)	NUMBER OF EVENTS OF EXCESS POWER BAND USAGE
5	10
10	20
15	30
20	50
25	75
30	100

Another alternative to track the exceptional customers would be to monitor the peak hourly powers of non-domestic customers monthly for a period of one year; in practice, this applies to customers in agriculture, small-scale industries and services. In other words, the customer’s highest hourly powers would be monitored monthly. It is typical for customers of this kind that the hourly powers remain relatively constant at an annual level. For instance, a customer’s powers could be below 15 kW for 11 months while being 25 kW for one month. Consequently, the customer’s normal power band would be 15 kW. An alternative could be that the customer would notify the DSO of exceptional power consumption for instance through a web-based online service and subscribe to a smaller band.

Another way to take the events of excess power band usage into account is an excess usage charge. The customer would pay the charge for the months exceeding the power band, in principle for one or two months. Customers of this kind should also have an opportunity to affect the size of their power band, regardless of the events of excess usage. There are customers similar to the customer of Figure A-26 also in other customer groups, for instance in small-scale industries. However, these customers have typically very limited opportunities to regulate their power consumption. If the events of excess usage occurred over a period of more than three months, the customers could be steered directly to a larger power band. The excess usage could be charged for the months when the events of excess usage occurred; yet, by allowing excess usage only for two months, after which the DSO would automatically shift the customer to a larger power band. The same approach could be taken also to ordinary low-voltage customers. If the number of allowed events of excess usage were exceeded, alternatives would be either to shift the customer to a larger band by the DSO or charge the customer for the excess usage. It is not reasonable to allow excess usage for more months than suggested here, because the model becomes too complicated to apply.

The charge for the excess power band usage could be based on various alternative models. Here, we introduce a few of these. The guiding principle in the excess power band usage should be that the customer, in addition to the normal monthly power band charge, pays an extra charge, the total amount of which is higher than the monthly charge of the next larger power band. The principle is illustrated in Table A-9. The unit prices are fixed prices, and the steps between the power bands are of equal size. In other words, if the amount of a monthly charge for a 5 kW band is 20 €/month and the power band charge for a 10 kW band is 40 €/month, the steps would be at intervals of 20 €. In that case, the charges for excess power band usage should be more than 20 € in order for the charge to be a real extra charge stimulating the customer to avoid excess usage of the power band.

Table A-9: Formation of charges for excess power band usage. The unit prices for power bands are examples only.

POWER BAND	PRICE	MONTHLY CHARGE	EXCESS USAGE CHARGE	MONTHLY CHARGE
(kW)	(€/kW, month)	(€, month)	(€, month)	(€, month)
5	4	20	24	44
10	4	40	24	64
15	4	60	24	84

The example above could be a suitable calculation method for excess usage. Electrotechnical determination of charges for excess power band usage can be carried out as follows. The

charges of mobile operators for exceeding the minute packages are typically threefold compared with the package prices. Similarly, in the power band scheme, the charge for exceeding the power band could be threefold compared with the normal power band charge. In other words, a threefold charge would be multiplied by the unit price of the power band and by the highest power exceeding the power band. Now, if the excess usage were 2 kW, in the case of Table A-9 this would mean $3 \times 4 \text{ €/kW, month} \times 2 \text{ kW} = 24 \text{ €, month}$.

Another option would be to add up the events of excess usage, in which case they would constitute the customer's energy rate. Now, excess usage below 100 kWh could cost 24 € per month, while excess usage above 100 kWh would cost for example 36 €/month. In this option, similarly to the other alternatives, the customer is not charged for excess usage events, if their number remains below ten.

Although we have now considered power band excess usage, the related charges and the customers' consumption behaviour, we are not able to say exactly how the customers' consumption habits will be affected by the power band pricing. Therefore, pilot studies on the topic are required. The objective of this section has been to show which issues are worth addressing in the implementation of the power band scheme, and which mistakes should be avoided. The principles introduced here represent suggestions and ideas that might work. In practice, pilot studies could be conducted in the field to determine the most viable basis for the pricing of excess power band usage. It is also important that the DSOs apply similar practices in the initial stage of the pricing scheme to avoid misunderstandings.

A 3.7.2 Power band: energy efficiency perspective

An advantage of the power band scheme is the incentives it provides for energy efficiency. Energy efficiency is a broad concept, and therefore, when considering the electricity market, the effects of the power band scheme should be addressed from the perspectives of both the customer and the distribution system. The following figures provide the AMR data of a few customers. The points in the figure, that is, the customer's hourly powers, show that the customer has opportunities to change over to a smaller power band, in other words, to improve the energy efficiency, and thereby affect his/her distribution pricing.

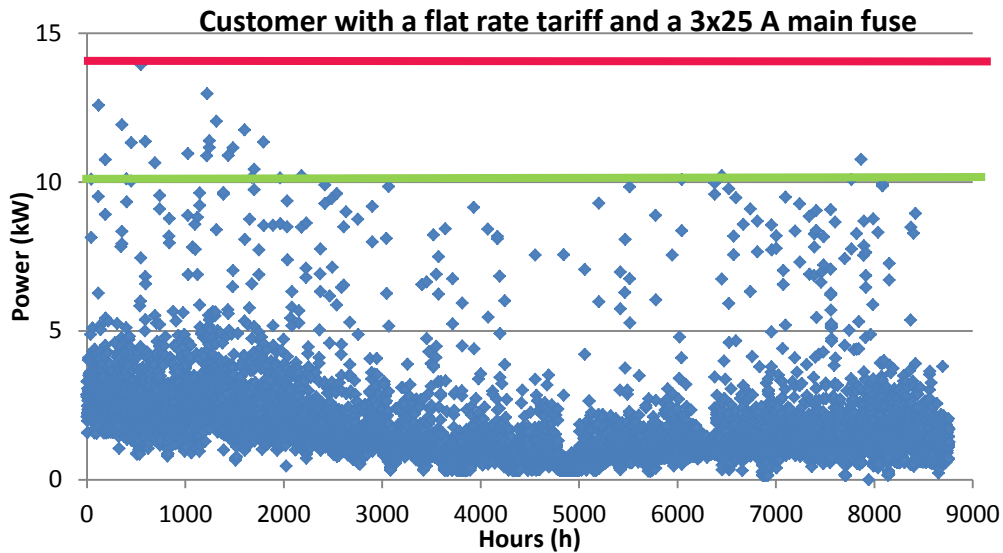

Figure A-26: Mean hourly powers of a domestic customer for a period of one year. The figure shows that the customer obviously has potential to scale his/her power band down.

The red line in the figure depicts the customer's highest hourly power at present. Now, according to the highest hourly power, the customer would subscribe to a band of 15 kW. If the customer scaled the band down to the 10 kW level indicated by the green line in the figure, his/her distribution charge would become lower. This approach may be considered to represent the concept of demand response, which is an example of energy efficiency from the perspective of the distribution system. Demand response would mean that the customer would not use all his/her electric devices at the same time, but would shift his/her electricity consumption or cut it down so that the consumption would be more evenly distributed among the hours of the day. For the customer of Figure A-26, the hourly powers often exceed 10 kW at the beginning of the year. If the customer had opportunities to shift his/her consumption or cut it down at the hours of the highest powers, the idea of demand response would materialise and the energy efficiency would improve from the customer's point of view. Demand response is essential also for the distribution system as it can be used as a means to boost the efficient use of network capacity. In practice, considerations are based on market-based demand response, but in an optimal situation, the aspects of both the network and the markets are simultaneously taken into account when demand response is carried out.

The second customer in Figure A-27 has even more potential for demand response. If the customer were charged for the highest hourly power, he/she would have a band of 20 kW in the initial stage when changing over to the power band pricing scheme. In reality, the customer would do well with a 10 kW band, and he/she could be able to subscribe to a 5 kW band by adjusting his/her consumption habits or by pursuing energy efficiency. Here, it is however worth noticing that optimisation of the band would not be mandatory, and it would not lead to consumption control or other similar situations. Almost all customers have potential to scale their power band down.

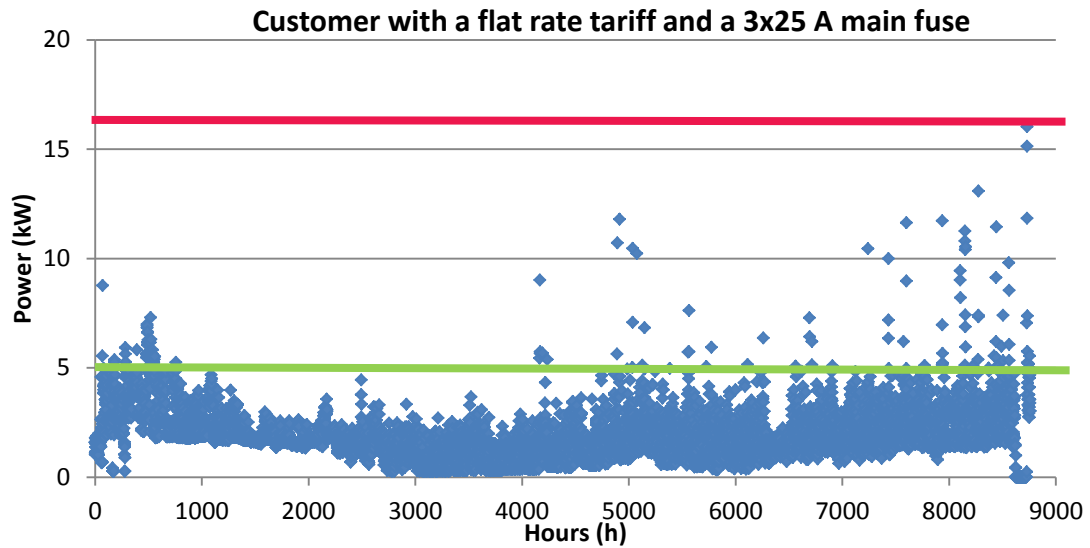

Figure A-27: Mean hourly powers of a second domestic customer for a period of one year.

The effects of actions towards energy efficiency are clearly visible in Figure A-28, which illustrates the hourly powers of an individual customer for three consecutive years. Although there are no exact background data available of the customer's consumption habits, the figure shows clearly that the customer's load curve has levelled out and the peak power has decreased. The customer has not had a power band available, yet his/her behaviour has developed similarly as if steered by a power band.

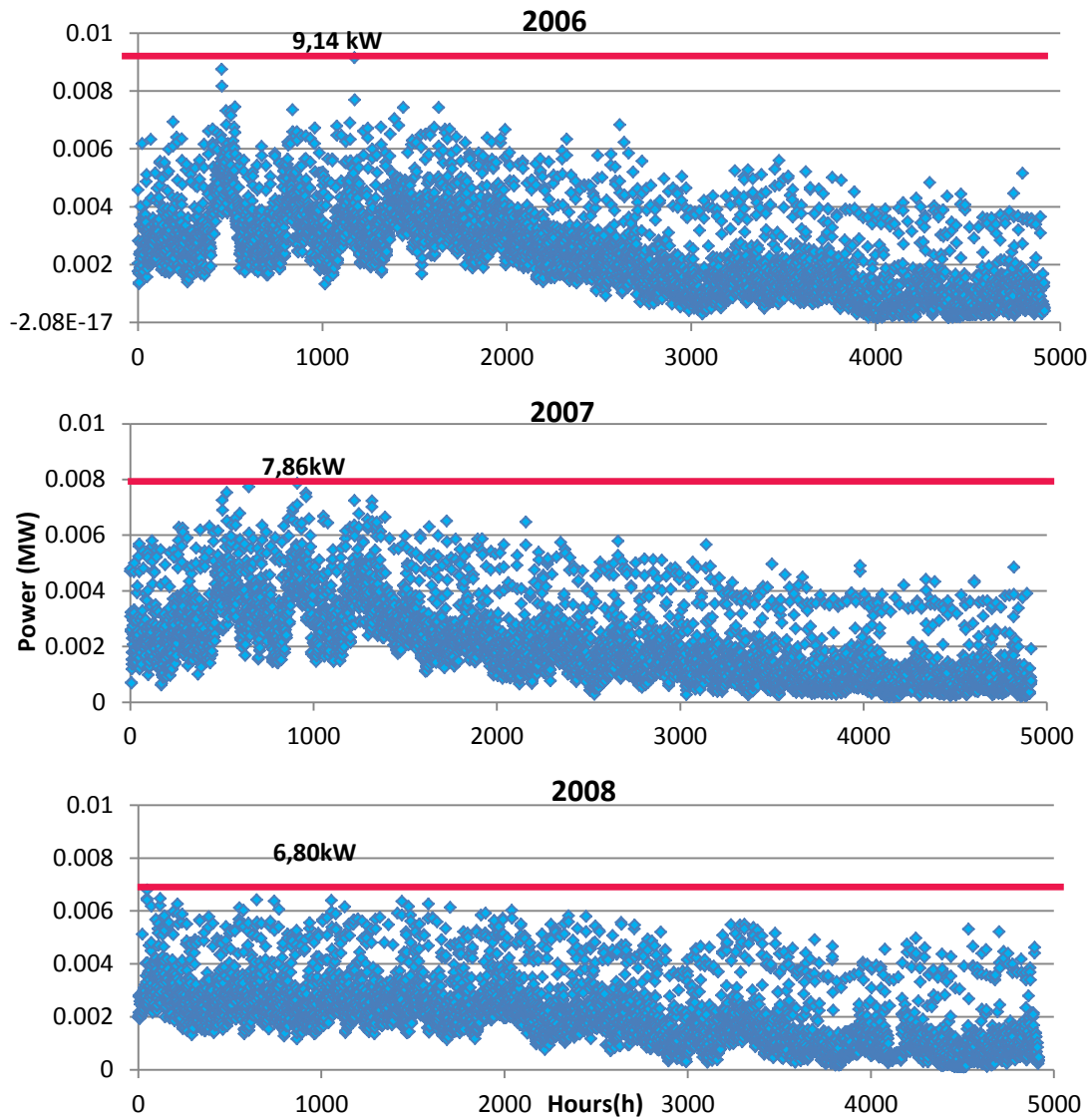

Figure A-28: Mean hourly powers of a domestic customer for three years. The customer’s data have been measured from the beginning of the year until July (4 940 h). The energies and mean powers for the period are: year 2006: 11.9 MWh and 2.41 kW, year 2007: 10.5 MWh and 2.13 kW, year 2008: 10.4 MWh and 2.11 kW. The lowest temperatures have been -29.7 °C (2006), -35.5 °C (2007) and -18.9 °C (2008).

We can see that a customer can significantly improve his/her energy efficiency by adjusting his/her consumption habits; for instance, it is maybe not necessary to inefficiently keep all electric equipment on at the same time. The customer can cut down unnecessary electricity consumption, for instance by switching lights off when not needed. Energy efficiency is also promoted by avoiding the unnecessary simultaneous use of all electric equipment. The customer also has other, more powerful incentives to replace devices that consume large amounts of electric energy and power. For instance, accumulating electric heating can be replaced by a full-power capacity ground heat pump. Now, a considerably smaller power band can be selected, and the consumption of electric energy is reduced.

There are also other reasons why the power band pricing scheme can be considered as a tool to promote energy efficiency. In Finland, most of the peak load in electricity generation is produced by methods that generate the largest emissions. If the consumption peaks can be reduced at the national level, we may assume that it is also possible to reduce the peak powers and thereby have a positive impact on energy efficiency and reduction of emissions. This is illustrated in Figure A-29.

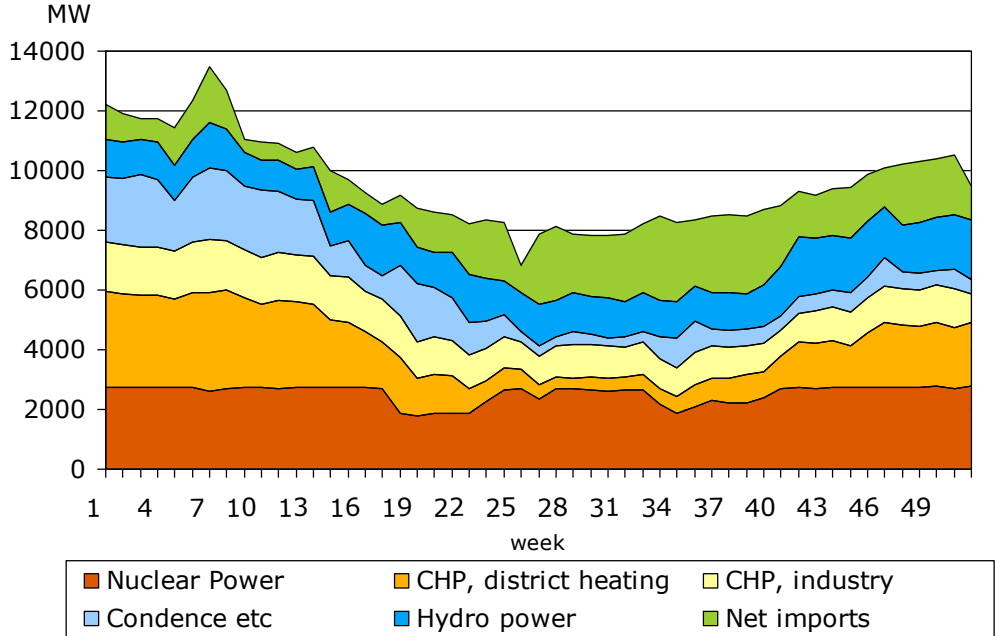

Figure A-29: Temporal variation of the electricity purchases according to weekly mean powers in Finland in 2011 (ET 2011).

If the amount of power and energy consumed can be reduced at the national level, also the use of renewables in energy production can be boosted. This supports the energy efficiency targets of the EU. Moreover, in electricity transmission and distribution, the energy efficiency would show as a reduction in transmitted energy and powers, and thereby, as reduced losses.

A 3.7.3 Effects of power band for different stakeholders

The features of the power band from the perspectives of different stakeholders are given in Figure A-30.

- Cost reflective, intelligible and transparent
- Customer has genuine opportunities to affect the distribution charge
- Encourages distributed generation
- Encourages efficient use of energy
- Supports the EU energy and climate policy
- Promotes the energy efficiency targets
- Does not conflict with the regulation and legislation
- Allows demand response
- Promotes well-functioning electricity markets

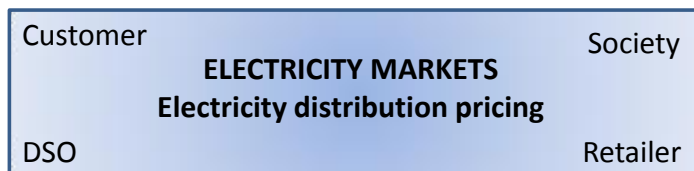

- Enables sufficient and predictable revenue streams also in the future
- Cost reflective
- Encourages customers in optimization of electricity use from the network perspective
- Technically feasible (metering + control)
- Enables market-based demand response
- Compatible with the retail tariff

Figure A-30: Features of the power band from the perspectives of different stakeholders in the electricity market.

For the customer, the power band pricing scheme would be cost reflective, as the customer would only pay for the network capacity he/she has used or reserved. The distribution tariff would thus be unambiguous, as it would have one tariff component only. Two- or three-component tariffs would confuse customers, similarly as the present distribution pricing scheme. The intelligibility of the power band would be supported by the fact that the concept of band is already familiar to customers for instance from internet broadband. In the power band scheme, the customers would have a genuine opportunity to affect their distribution charges, and the scheme would not provide contradictory steering signals. The power band would also partly encourage customers to develop distributed generation, if the customers could thus decrease their subscribed power. The primary benefit of the power band is probably that the customers are encouraged to use energy efficiently from the perspective of the distribution network; in other words, to cut down the required distribution capacity.

From society's point of view, the power band would promote the energy efficiency targets and support the climate and energy policy, where energy efficiency is considered from a holistic system perspective. Power band would enable market-based demand response, and thereby promote the functioning of the electricity markets. In addition, it seems that the power band pricing scheme does not conflict with the prevailing regulation and legislation.

For a distribution system operator, the pricing scheme would guarantee predictable revenue streams, as the fixed monthly charge for all the customers around the year would help in keeping the turnover at a desired target level. That way, no significant changes would take place in the turnover between years, as this has been taken into account when preparing the pricing scheme. The previous chapters have addressed cost formation for DSOs. It has been shown that the power and fixed charges constitute a significant proportion of costs. The

power band would, in particular, be cost reflective, and support the objectives defined above. According to the energy efficiency directive, the distribution system operators should provide services and encourage customers in efficient optimisation of electricity consumption. By the power band pricing scheme, the requirements set by the directive are met. When remotely read meters have been installed at all customers, there is infrastructure required for the power band. However, some effort will be required from the DSOs to upgrade or modify their information systems to meet the needs of the new tariff scheme.

Power band as a distribution pricing scheme would also be compatible with the retail tariff, and thus, distribution pricing would be a feasible option for the retailer. The retailer would have more opportunities to develop its price products, and the retail tariffs would not be confused with the distribution tariffs. The distribution pricing scheme would also enable market-based demand response, yet the power band would reduce the potential of the demand response. The demand response potential would decrease, because the customer's controllable power would be smaller as it would be limited by the subscribed distribution capacity. On the other hand, the power band would limit the occurrence of high power peaks and encourage the customers to optimise their total consumption.

A 3.7.4 Marginal costs of the power band

A benefit of the power band is that the changes in the power consumption affect both the customers' distribution charge and the DSO's long-term marginal costs by the same mechanism. Thus, it has to be ensured that the prices determined for the bands allow network investments when the loads increase. The situation is illustrated by an example of the replacement value of a distribution network of a DSO in relation to the peak powers at different voltage levels. The replacement value is converted into annual costs with a 40-year lifetime and a 5 % interest rate.

low-voltage networks	320 €/kW = 18.6 €/kW, a = 1.55 €/kW, month
medium-voltage networks	300 €/kW = 17.5 €/kW, a = 1.46 €/kW, month
primary supply station level	100 €/kW = 5.8 €/kW, a = 0.48 €/kW, month
whole DSO	720 €/kW = 42 €/kW, a = 3.5 €/kW, month

The company turnover is 4.4 M€ and the annual peak power 50 MW. Thus, we obtain a turnover to power ratio of 88 €/kW a year, that is, 7.33 €/kW a month. In practice, the price for the power band has to be determined more accurately, as discussed above. This price, however, can be used as a baseline against which to compare the above network marginal costs. We can see that the power band price determined this way would ensure the funding for the network reinforcement investments.

A 3.7.5 Transition to the power band pricing scheme

The present distribution pricing scheme is in need of reforms; as shown in this report, these reform demands could best be met by the power band pricing scheme. Considering distribution pricing, the transition to the power band scheme could take place either partly or completely, depending on the interests and objectives of the stakeholders in the electricity

market. To guarantee the security of an individual customer, transition to the power band pricing scheme should be gradual. In the initial stage, the power band would be included in the standing charge of the electricity distribution. Instead of the fixed distribution charges and standing charges that are based on the size of the main fuse, the network companies could provide power-based bands. In the power band model, there would be only one pricing scheme, which would, however, include more steps than the present scheme of fixed charges, which is based on the size of the main fuse. Because the distribution pricing practices vary between the DSOs, there is an obvious need for harmonisation in the field. In the DSOs, the target could be to replace the standing charge by the power band during a period of one year. At the earliest, this could take place in 2015, when all customers would already have AMR meters at their disposal, and the DSOs would have time to ensure that the metering systems are operational. The time of transition would be the same for all DSOs, and all DSOs should participate in the reform to guarantee that all the customers and retailers all over the country would be treated equally.

The power bands offered by DSOs would be given in kilowatts equally by all DSOs in the pricing scheme. First, it would be advisable that all DSOs also applied the same steps in the power band system. The bands could start from 5 kW and continue in steps of 5 kW, in other words, 5 kW, 10 kW, 15 kW and so on. The steps of this size are justified by the present main fuse system and because of the equitable treatment of the customers. In the initial stage, when changing over from the standing charges to the power band, the steps between the power bands should be quite large; this way, too frequent occurrences of excess power band usage could be avoided in the first years. On the other hand, we are not able to say how the consumption habits of the customers would change, and therefore, the steps between the power bands should be quite large.

Information of the transition to the new power band pricing scheme should be provided well in advance. Hence, if the transition were carried out systematically from the beginning of year 2015, the customers should be informed of the process at the beginning of 2014 at latest. Information about the transition to the new distribution pricing scheme could be provided for instance together with the electricity bills, on the DSOs' web pages and in the media. The customers would be informed in their bill about their highest hourly power of the present year and the resulting power band and monthly charge. Together with the present distribution price and consumption data, the customer would be informed of the opportunities to scale the power band down and cut down the electricity bill.

A suitable power band for the customer would be determined directly based on the DSO's customer data of the hourly consumption. For instance in the initial stage of the transition process, when the power band would replace the standing charge, the billing could be based on the highest hourly power. The customers would be allowed to exceed their power bands for instance ten times a year in each power band. This rule could be applied for a few years. When the customers are familiar with the new pricing scheme, the bands could be offered in steps smaller than 5 kW, simultaneously increasing the weight of the power band in the distribution pricing.

As an increasing part of the customer’s distribution charge would be based on the power band, the size of the power band could be determined basically according to the same principle as before. Now, the customer would be allowed more events of excess power band usage, which would increase in size along with an increasing power band size. At the same time in this stage, the customers would be charged for excess usage that exceeds the number of allowed events. Before changing over from the combined power band and energy rate to a full power band, the proportion of power band pricing of the distribution price should be increased to at least 50 %. This stage would be reached faster by some DSOs than by others. The standing charges of some DSOs are already at a higher level when compared with other companies.

During the years following the distribution pricing reform, the target would be to increase the proportion of the power band in the distribution charge at least to half of the charge. Full power band pricing could be introduced to the customers over a period of several years. For instance, after changing from the standing charge to the power band, the proportion of the customers’ power band charge in the distribution pricing could be increased and the proportion of energy rate could be decreased, as shown in Figure A-31. The process should take several years to ensure that the changes in one year are not too radical for the customers. For enterprises, the changes over several years should not be too radical either to avoid unreasonable damage to the business.

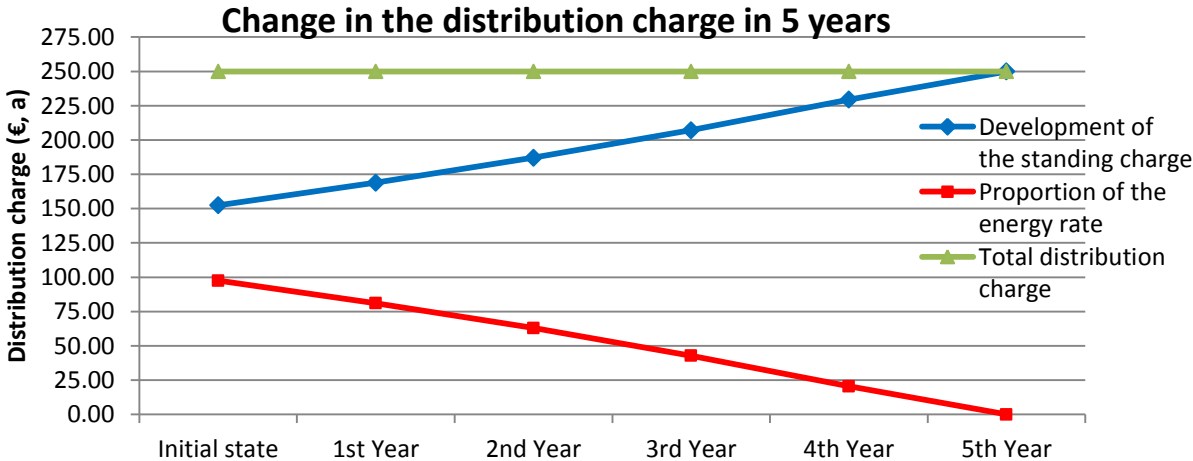

Figure A-31: Changes in the distribution charge components for a K1 type electricity user of a DSO when changing over to the power band pricing scheme.

The new scheme would be launched in 2015 at the earliest, when the power band pricing would replace the standing charge. Over the coming few years, the proportion of the standing charge, that is, the power band, would increase, and the proportion of energy rate would decrease. The distribution charge as a whole would remain constant or at the target level determined by the DSO.

A 3.7.6 Implementation of the power band pricing scheme

In this report, only the outlines of the implementation of the pricing scheme have been discussed. However, for the practical implementation of the scheme, the system has to be piloted in an actual operating environment.

The customers' present standing charges would first be converted into a power band. For the purpose, the DSOs should collect AMR metering data of each customer's highest hourly power of the year. These data would be used to determine the customer's power band in the initial stage. Moreover, the DSOs should determine the charges collected at present from the customers' standing charges for distribution. After this, there are various alternatives to determine the unit price, of which the DSO can choose the one that best suits its purposes. However, it would be important to have a fixed price as the unit price (€/kW, month) when converting the standing charge into a power band; thus, it would be easier to adjust the prices in the future and avoid any volume discounts.

An alternative would be that the DSO determines a single unit price €/kW for a year based on the AMR data and standing charges, which is applied to all customers of the DSO. In that case, the unit price €/kW would be constant for all customers, and it would be adjusted to a level where the revenues collected from the standing charges remain constant, thereby guaranteeing that also the changes in prices remain reasonable for the customers.

Another alternative would be to group the customers according to their power bands so that for instance the customers with a 5 kW band would comprise one group, the customers having a 10 kW band another, and so on. The revenues produced by the standing charges of the customer group are added up and divided by the number of customers in the customer group. The resulting annual power band charge has to be further modified between the customer groups so that the unit price of the band is constant. Thus, with a fixed unit price for the band, for instance 2 €/kW a month, a 5 kW power band would cost 10 € a month and a 10 kW band 20 €.

First, the DSO would automatically determine a suitable band for the customer based on the metered hourly data for the highest hourly power of one year. For instance, if the power band were included in the standing charge for distribution in 2015, the customer billing could first be based on the highest hourly data metered for year 2014. The customer would have a right to switch the power band once a year. The reason for allowing only one switch a year is that customers with electric heating would probably try to order a smaller band for summer than for winter, when the consumption of electrical energy is considerably higher. Furthermore, the power band is intended to be a fixed monthly charge around the year. The purpose is not to randomly switch the power band and the related monthly charge. A year may sound a long time; however, the contracts with mobile operators and electricity retailers are typically made even for two years. During the transition, if the customer wanted to have a smaller power band than the one determined by the DSO, the customer should notify the DSO through the company's internet service or by calling the customer service. Naturally, a prerequisite for the switch is that the band would be adequate for the customer. If this condition were not met, the DSO would inform the customer about an excess usage of the band for instance through an online service, and switch the band automatically to a larger one or charge the customer for the excess usage. If the customer wants to subscribe to a smaller band than what is suggested by the DSO, the customer should be charged for the switch. This way, unnecessary switches between the power bands could be avoided.

In the initial stage, that is, when switching from the present standing charge to the power band, the customers would be allowed to exceed their band ten times in each power band. In practice, the DSO would suggest a suitable band for the customer, in addition to which the customer could choose a suitable band for him/herself. This would remove the risk of an oversized power band.

In the power band pricing scheme, the customer has an opportunity to influence the subscribed band and thereby the amount of the distribution charge. It would be advisable to inform the customer about the opportunities to reduce the power consumption similarly as about the means to reduce the energy consumption. This information could be given together with the electricity bills and in the DSO's newsletters. Either the electricity retailer or the DSO could provide the customer with tips on energy efficiency or how to switch to a smaller power band.

The process of including the power band scheme fully in the distribution pricing would be carried out over several years. The power band could replace the present standing charge in distribution pricing as soon as the DSOs have managed to raise the proportion of the power band price to the 50 % level of the total distribution price. After this, a few more years are required to reach a full power band pricing scheme. At the same time, it would be necessary to modify some of the principles related to the power band in order to avoid any changes that would be unbearable from a customer's point of view.

The power band could be determined on a similar basis as previously, that is, by the highest hourly power of a year, because the customers are already familiar with the principle. Now, more events of excess usage would be allowed for the customers depending on the size of the power band. For example, a band of 5 kW could be exceeded ten times a year, and a 15 kW band 30 times. The customer would be charged for excess usage exceeding the allowed limits, or he/she would be shifted to a larger power band. In this context, the DSOs could also introduce power bands in smaller steps; the bands could be for instance 5 kW, 8 kW, 10 kW, 13 kW and so on. In the future, the steps between the bands could be even smaller.

When changing over to a full power band scheme, special attention should be paid to exceptional customers, the power consumption of which during one month may be multiple compared with the consumption for the rest of the year. For customers of this kind, a stepped scheme should be used for the events of excess power band usage, or the customers should be tracked based on their monthly hourly peak powers, or the customers themselves should inform about their desire to select a smaller power band either through an online service or by contacting the DSO by phone.

A 3.7.7 Power band as a distribution pricing scheme: a summary

As a whole, the transition process from the present distribution pricing scheme to the full power band scheme would take several years. The transition process is illustrated by figures and tables below.

In the initial stage, the power band would replace the present standing charge. This would be carried out by determining the highest hourly power from a customer’s hourly data for one year, which the DSO would use as a basis to determine the customer’s power band. The DSO would determine the prices for the power bands according to its target levels. The smallest band would be 5 kW and the bands would be defined in steps of 5 kW. Hence, all the customers would have same power bands, but the energy tariffs for the distribution could still be selected from various alternatives. The power bands for the customers of a DSO and the resulting monthly charges would thus be as shown in Table A-10.

Table A-10: Power bands and monthly charges when changing over from the standing charge to the power band.

YEAR 2011	Customer 1	Customer 2	Customer 3	Customer 4	Customer 5	Customer 6	Customer 7	Customer 8
Max (kW)	16.8	10.07	13.39	9.75	10.11	10.55	8.23	15.68
Power band (kW)	20	15	15	10	15	15	10	20
Price (€, month)	40	30	30	20	30	30	20	40

In the initial stage, the customers would have an opportunity to choose whether they accept the power band suggested by the DSO or whether they would like to have some other band. In the initial stage, the selection of power band would be free of charge. The customers could determine a suitable band for themselves by using the DSO’s online service or by calling the DSO and inquiring about possible solutions for a suitable power band. In Figure A-32, the power band of a customer would be 20 kW.

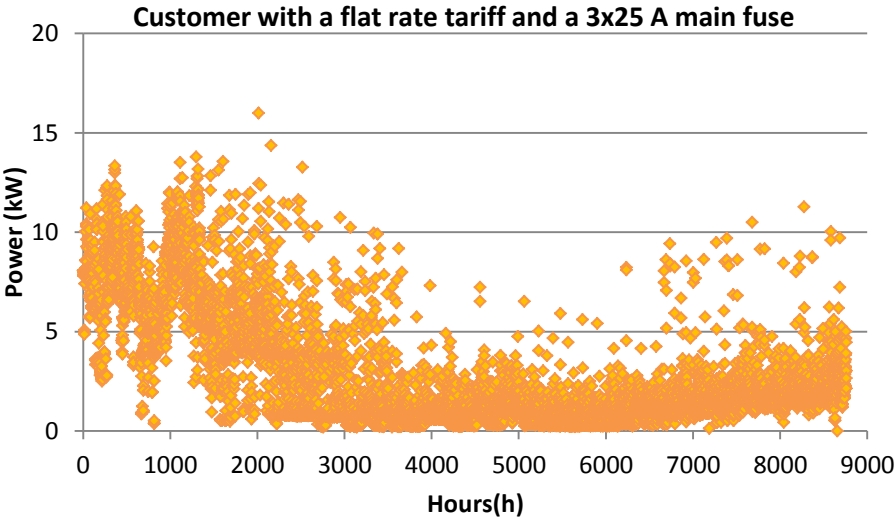

Figure A-32: Hourly data for one year of a domestic customer living in a detached house.

The customer decided to take a 15 kW power band instead of the 20 kW band recommended by the DSO. The customer knows now that he/she has a power band of 15 kW, which costs 30 € a month, and he/she may exceed the band ten times during the year, after which he/she is automatically shifted to a larger power band. As the power band replaced only the standing charge, the customer will have to pay an energy rate in the distribution charge based on the consumed energy. Consequently, the basis for billing could be as illustrated in Table A-11.

Table A-11: Pricing example when changing over from the standing charge to the power band.

Unit price 2 €/kW, month	5 kW	10 kW	15 kW	20 kW
Power band (€, kk)	10	20	30	40
Allowed excess usage events (number, a)	10	10	10	10
Flat rate distribution tariff	Consumption charges cent/kWh 2.76			
			day	night
Time-of-day distribution tariff	Consumption charges cent/kWh 3.41 1.69			

The process would continue so that the DSOs would raise the proportion of the power band to a 50 % level in the distribution pricing over a period of a few years; in other words, the proportion of the energy rate in the distribution pricing would decrease. The DSO would suggest a suitable band for the customer, thereby avoiding an oversized band. Should a customer like to have a larger band, he/she could order it for free. If the customer wanted to have a smaller band than the DSO suggests, he/she would have to pay a small extra service fee for the switch.

After the most critical transition phase, the DSOs could start to offer power bands in smaller steps, for instance at 5 kW, 8 kW, 10 kW and 13 kW. The practice for the determination of the power band would be the same as before: The customers have a power band, which they may exceed for a certain number of times. In this stage, it may not be advisable to adjust the basis for the determination of the power band any longer. When changing over to the power band, a unit price of 2 €/kW a month is assumed for the standing charge. When the proportion of the energy rate has been removed, as a result, the unit price of the power band has increased for instance to 4 €/kW. Now, the customer prices would be as shown in Table A-11.

Table A-12: Price formation when changing over to a full power band scheme.

YEAR 2011	Customer 9	Customer 10	Customer 11	Customer 12	Customer 13	Customer 14	Customer 15
Power band (kW)	8	15	10	8	10	8	13
Price (€, month)	32	60	40	32	40	32	52

As the weight of the power band increases in the distribution pricing, the number of allowed excess usage events for customers should be increased in steps. This would provide flexibility in the pricing. If the customer is not able to stay within the limits of the subscribed power band, that is, the number of allowed events is exceeded, he/she is automatically shifted to the next power band. The practice applied to the determination of the power band is still that the DSO suggests a suitable band, and the customer may either switch it or keep the suggested band. The power band pricing scheme is not suitable for all customer types because of the price structure; therefore, an excess usage charge for one or two months should be introduced for such customers. An example of distribution pricing in a full power band scheme is illustrated in Table A-12.

Table A-13: Example of distribution pricing in a full power band scheme.

Data: 4 €/kW, month	5 kW	8 kW	10 kW	13 kW	15 kW	18 kW	20 kW
Power band (€, month)	20	32	40	52	60	72	80
Allowed excess usage events (number, a)	10	15	20	25	30	35	40
Excess usage charge (€, month)	24						

In the later stage, the DSOs could offer power bands in smaller steps, such as 1 kW, to their customers. In this stage, the customers should have a home automation system of some kind, a consumption display or similar to monitor the consumption at an hour level.

A 3.8 Conclusions

Promotion of energy efficiency and reduction of the environmental effects of energy generation call for changes in the entire energy system. Here, distributed generation by renewables such as solar and wind power play a key role. As it is difficult to predict generation of this kind, demand response is required to balance variation in consumption and generation. Moreover, new pricing schemes are needed to encourage the customers in energy efficiency and demand response. The target is to establish a pricing scheme for DSOs that encourages the end-users to behave so that the energy efficiency of the whole energy system, including generation, transmission and distribution, is maximised and the total costs to the national economy are minimised. Furthermore, the pricing scheme has to be cost reflective, equitable and intelligible to all parties involved.

The study has addressed opportunities to develop the tariff structures from the perspectives of distribution system operators, customers and other stakeholders in the energy sector. The present tariff structure has to be developed, in particular because of its inadequate cost reflectivity and weak incentive effects. These issues will raise problems especially under the changes that the energy system will face in the future; the measures to boost energy efficiency will impact on the amount of transmitted energy and the power demand of the customers, and thereby the revenues and expenses of the DSO. In practice, the expenses of a DSO mainly depend on the peak power on the network, whereas in the present tariff structures, which have a fixed standing charge and an energy rate, a majority of the revenues are based on the amount of transmitted energy. Thus, in the present tariff scheme, changes in the electricity consumption do not affect the revenues and expenses equally. For instance, a customer's own small-scale electricity generation or a heat pump in a building with electric heating improves the total energy efficiency and decreases the volume of energy transmitted on the network, yet does not usually impact on the peak power taken by the customer from the network. Thus, actions of this kind reduce the revenues of the DSO, but do not influence the expenses. From the distribution network's viewpoint, the present tariff structure does not encourage the customers to optimise their electricity consumption either, and thus, has no incentive to improve the energy efficiency of electricity distribution. Hence, we may state that the tariff scheme should be developed to be more cost reflective for the DSO, and to encourage the customers to optimise their electricity consumption also from the perspective of the distribution network. Furthermore, special attention should be paid to ensure that the tariff scheme does not lead to conflicts of interest between other stakeholders in the field. Now, it is a suitable moment to develop the tariff scheme, as the tariff reform can be made parallel to the adoption of AMR meters and possible changes in the retail market model.

Considering the alternative tariff schemes discussed here, the power band pricing scheme meets best the targets set for the new tariff scheme. In the power band scheme, a customer's distribution tariff depends on the subscribed power band (e.g. 5 kW, 8 kW, 11 kW). A pricing scheme of this kind encourages the customers to optimise their electricity consumption so that the peak power demand is decreased. As the network capacity utilisation rate increases, the long-term costs decrease, which is also financially beneficial to the customers. Energy-based pricing of electrical energy, again, encourages the customers to cut their total energy consumption. The primary factor affecting the costs of electricity distribution is the peak power of the network. Thus, for the DSO, power-based pricing is cost reflective. It is also equitable to the customers, as the costs are divided between customers so that the customer causing a higher cost pays a higher price and vice versa.

If the market model for retail markets is developed so that the retailer is responsible for the customer gateway and also charges the proportion of the DSO to the customers, the retailer will have an incentive to steer the customer's electricity consumption toward an overall optimum for the market and the network. Now, the retailer optimises the control of customer loads, energy storages and generation according to the spot prices, simultaneously taking into account the optimal dimensioning of the power band. The size of the customer's power band can be increased, if the costs of the switch to a larger band are lower than the benefits achieved by the market-based load control. Correspondingly, a smaller band is chosen, if the savings provided by the switch to a smaller band are higher than the losses caused by the

decrease in the load control potential. In the above situation, the total energy efficiency, including electricity generation and distribution, is maximised, as the use of the network and generation capacity is optimised simultaneously. When the power band price corresponds to the marginal costs of the distribution network, and the spot price to the marginal costs of generation, the above-described scheme pursues an overall optimum of costs also at the national economy level.

The tariff scheme reform inevitably leads to changes in prices for individual customers. However, the reformed scheme is more equitable and provides better incentives for the customers; in the new scheme, the costs are also allocated better by the matching principle. The new scheme can be adopted gradually, thereby avoiding too radical changes for individual customers. At the same time, adequate revenues are guaranteed for the DSO both in the transition and the new tariff scheme.

A 3.9 Topics of further study

Tariff schemes and their effects have been discussed extensively in this report. The results obtained in the study have also raised some issues for further study, which are worth addressing in the future.

The report has addressed the effects of power band on the demand response in general. However, the effects of the distribution tariff on the market-based demand response have to be analysed in detail by taking into account the incentives produced both by the power band and the market-based demand response as well as the overall effects for the customer and the energy system as a whole.

The effects of the new tariff scheme have to be piloted in an actual operating environment before the scheme is adopted in a large scale. Special attention should be paid to the intelligibility of the tariff scheme for the customer, and to the actual effects of the tariffs on the customer behaviour. Simultaneously, the feasibility and potential of the above-described demand response should be investigated with different customers. In addition, opportunities to increase customer activity with respect to demand response should be studied.

A problematic issue when considering the tariffs for small-scale consumers is the billing of reactive power. Changes in the electric equipment possessed by customers also increase the small-scale customers' consumption of reactive power; nevertheless, there are no incentives to reduce the reactive power, as it has no effect on billing in the present tariff scheme. No changes are expected either, if the pricing is based on subscribed power, as suggested in this report. If the pricing were based on current instead of power, this would include reactive power also. Now the problem would be that the present AMR meters typically do not record current or reactive power, and thus, changes would be required in the metering systems. Furthermore, small-scale customers are also usually not familiar with the technical concept of reactive power, and this would cause problems in informing the customers about the billing principles. Small-scale customers' reactive powers can also be affected by various standards

for electric equipment, but the network tariff should nevertheless include a proper incentive to reduce the reactive power; however, the practical implementation requires further study.

In addition to analyses and results provided in this report, the legislative aspects associated with the power band should be investigated in cooperation with the respective ministry (Ministry of Employment and the Economy).

References of Appendix 3

Belonogova, N., Lassila, J., Partanen, J. "Effects of demand response on the distribution company business," In *NORDAC 2010*, September 2010, Aalborg, Denmark.

Directive 2006/32/EC of the European Parliament and of the Council of 5 April 2006 on energy end-use efficiency and energy services (Energy Services Directive).

EC 2011/0172. *Proposal for a Directive of the European Parliament and Council on energy efficiency and amending and subsequently repealing directives 2004/8/EC and 2006/32/EC*, Brussels, 22 June 2011.

Electricity Market Act (386/1995).

EMA 2010a. *Selvitys sähkötariffien hintakomponenttien kehityksestä vuosina 2000–2010* (Survey on the development of the price components in electricity tariffs in 2000–2010), in Finnish. Energy Market Authority (EMA), 31 March 2010.

EMA 2010b. *Sähköverkkotoiminnan tunnusluvut vuosilta 2007–2010* (Key figures of the electricity distribution business for years 2007–2010), in Finnish.

EMA 2012a. PowerPoint material on the price of electricity, in Finnish, 1 February 2012.

EMA 2012b. *Sähköhinnan kehitys* (Development of the price of electricity), in Finnish, 1 March 2012.

Energy Efficiency Agreements, [online], [Accessed 8 March 2012], Available from <http://www.energiatehokkuussopimukset.fi>.

T 2011. *Energy year 2011*. PowerPoint material of the Finnish Energy Industries.

Evens, C., Kärkkäinen, S. 2010. *Pricing models and mechanisms for the promotion of demand side integration*. Research Report. VTT Technical Research Centre of Finland.

Kärkkäinen, S., Farin, J. *Jakeluverkon siirtotariffien rakenteet* (Distribution tariff structures for the distribution network). *Sähkömarkkinakeskuksen julkaisuja 1/2000* (Publications of the Energy Market Centre 1/2000), in Finnish.

Laki energiamarkkinoilla toimivien yritysten energiatehokkuuspalveluista (Act on energy efficiency services of enterprises operating in the energy market) (1211/2009), in Finnish.

Nemesys. 2005. *Towards a Pan-Nordic Regulation for Distribution System Operations*. Final Report. Sumicsid AB.

Similä, L., Koreneff, G., Kekkonen, V. 2011. *Network tariff structures in Smart Grid environment*. Research report. VTT Technical Research Centre of Finland.

Sollentuna Energi, [online], [Accessed 15 March 2012], Available from www.sollentunaenergi.se, in Swedish.

Tuunanen Jussi. 2009. *Lämpöpumppujen vaikutukset sähköverkkoliiketoiminnan kannalta* (The Effects of Heat Pumps from the Perspective of Electricity Network Business), Master's thesis, Lappeenranta University of Technology, in Finnish.

Valtioneuvoston asetus sähköntoimitusten selvityksestä ja mittauksesta (Government Decree on determination of electricity supply and metering) (66/2009), in Finnish.

Appendix 4 Analysis of the stakeholders involved in the penetration of the new technologies in France

Raphael Marguet

Eva-Obdulia Garcia

A 4.1 Involved stakeholders for system integration of electric vehicles

A 4.1.1 Reminder on PEV/PHEV deployment forecast in France

PEV and PHEV integration will probably be one of the major modifications in the organization of both the transportation and electric network. Integrating EVs is more than just simply replacing fuel engine cars by electric engine cars. Habits, usages, organization, industry, responsibilities of the various stakeholders will all be modified.

If the integration of EVs could be simplified to 3 simple steps: 1-prototype studies, 2-small scale production and tests and 3-large scale production & integration, the French situation would presently be at step 2.

The deployment of Plug-in Electric Vehicles and Plug-in Hybrid Electric Vehicles in France is a subject that is closely looked at by the French government whom has identified national objectives of penetration of PEV/PHEV at the horizon 2025.

The launch of electric vehicles has already been tried before the years 2000 in various countries (in Europe, USA, and Japan for example) but without visible success. In order to not reproduce the past failure situation, the French government is putting significant effort in making the various stakeholders work together.

In order to attract the interested car manufacturers and boost the various stakeholders, the government placed a public order of 100 000 electric vehicles by 2015.

The national objectives in terms of EV fleet are the following:

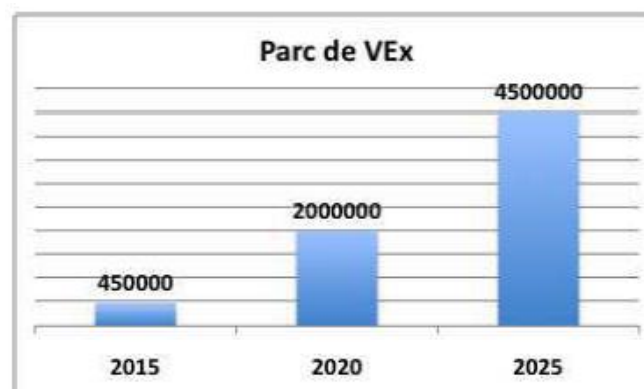

Figure A-33: Expected volume of EVs/PHEVs for France in 2015, 2020 and 2025.

For example, expected volume in 2020 is up to 2 million EVs. This is equivalent to a 5% penetration (includes vans and other regular vehicles). It corresponds to 15.000 EVs for a region of 500.000 inhabitants (study case of Rouen region) (source EDF). And in term of charging stations:

Number of terminals	2015	2020	2025
Private or company terminals	900 000	4 000 000	9 000 000
Public space terminals - normal charging	60 000	340 000	750 000
Public space terminals - fast charging	15 000	60 000	150 000
TOTAL	975 000	4 400 000	9 900 000

Table A-14: Objectives of total number of terminals

- More than 90% should be slow charging (3kVA) at home at off-peak hours (night).
- 7-8% will be secondary slow or accelerated charging (3, 22kVA)
- Only 2-3% of public charging spots will be for fast charging (43kVA)

A 4.1.2 The roles of the various stakeholders

Since the year 2000 the organization of the French electricity market kept on evolving until its total liberalization (including the residential level) which occurred in July 2007. The roles of all the different actors of the electricity market evolved at the same time. A description of the actors involved by the deployment of electric vehicles is below.

The Distribution System Operator (public actor)

The DSOs are in charge of the distribution of the electricity for medium and low voltage customers (industrial or residential). In France, one main historical DSO operates 95% of the distribution system. The 5% remaining are shared by about 170 small and local DSOs (called Local Distribution Companies). The DSOs do not own the distribution network but share, with the local communities, the investments costs.

Role in the deployment of EVs:

The main role of the DSOs will be to manage the distribution system depending of the new charging facilities installations. In some places, the current network will not be sufficient, and modifications will need to be made in order to connect a charging facility. Maximum power distributable and usual network local loading will need to be taken into account.

The Transmission Network Operator (public actor)

The TSO, apart from transmitting electricity from producers to the distribution system, has to manage the production/consumption balance of the electric system and ensure the overall system security.

In France there is only one TSO. In order to keep the production/consumption balance, it has to plan one day ahead (in coordination with the producers), supplemented by hour ahead schedules, the national load curve and a corresponding generation adjustment program with the available generation capacity. The balance and the generation program are then adjusted in real-time.

Role in the deployment of EVs:

The TSO will have to adapt their daily adjustment since the presence of EVs on the grid will have an impact on the load curve. Depending on how the EV charges will be managed, the impact on the load curve will be different (evening peaks, load shifting during the night, etc).

The retailers/suppliers (public or private actors)

The retailers are the commercial link between energy producers and consumers (industrial or residential).

Role in the deployment of EVs:

With the development of smart meters and the possibility to give more than one tariff orders, the retailers will be able to deal with a new type of customer, the charging facilities, and therefore propose new types of contracts and energy services, adapted to their role of selling electricity charges to EVs' owners.

The service providers (public or private actor)

Service providers in the usual French electricity market are often also retailers. But they provide other services than just "selling" electricity. Other services can be, for example, consumption diagnosis tools, help in energy management, etc. These services can be useful for high energy consumer industrials.

Role in the deployment of EVs:

Electric vehicles are characterized by a more complex energy management compared to a fuel engine vehicle. Fuel engines only need to be filled up regularly (when fuel level is low) and this is an easy task (fuel station in abundance, promptness of a tank filling). Unlike fuel engine vehicles, electric vehicles need a more complex energy management. A charging is not instantaneous (generally a few hours), and the distance range is smaller. Therefore, users will need to organize their vehicle charging depending of their needs and their availabilities.

In this context, service providers may propose services that can help the users in their vehicle energy management (by internet, car display or phone display of information). They will certainly propose services to the charging facilities which will need to manage their energy distribution to the EV fleet.

The manufacturers of the EV technology (private actors) including Batteries

Manufacturers are of course very much involved in the development of PEVs/PHEVs. Their role is crucial in the development of new technologies making the EV solution more attractive (better range performance, battery life, lower investment costs...). But their role will also be important in the development of the charging facilities. Standardization and normalization (for terminal plug types, current and voltage level, etc) will be important in order to facilitate the deployment of the whole EV field.

With respect to battery development and recycling, industrials will also play a key role in the deployment of PEVs/PHEVs. (see section 1.4.2).

Electricity terminal station providers

Similarly to gas stations, there will be a need for electricity terminal charging stations. It can be of different types: additional service attached to regular gas stations, battery service (such as betterplace), specific electricity terminal fast charging stations and battery management,

recycling, etc. this type of stakeholders are not settled yet but may emerge with the PEV/PHEV deployment.

Later, there may be the appearance of e-mobility operators.

Cities and local communities

It is expected that most of the PEVs/PHEVs usage will be within the cities. In addition, cities in France have to propose and fulfil an energy-climate plan. Clean transportation is part of these plans. As such, they take part in facilitating or even planning the development of PEVs/PHEVs including the deployment of charging infrastructures. Currently, several French cities are involved in demonstration projects related to the development and integration of PEVs/PHEVs as part of “smart eco-cities”

Furthermore, the French government planned, in its EV deployment plan, to count on the cities to develop public charging stations (meaning charging stations in public parking places). In this context, a new actor is planned to be created: a subsidiary of a public actor which will work for the cities to help them in the development of charging stations on their territory

Regulatory bodies and local energy agencies

The development and deployment of PEVs/PHEVs will involve several stakeholders (as detailed above) and the related business model is still not settled. Therefore, regulation needs to be defined with respect to the proper interaction of these stakeholders as well as with respect to defining appropriate incentives. As such, both the French government and the CRE (French Regulatory Commission) form the regulatory stakeholders in France.

Energy agencies such as ADEME are also involved in supporting research and demonstration projects as well as development roadmaps for PEVs/PHEVs in France.

A 4.1.3 Integration of PEVs/PHEVs

The rate of integration of PEVs and PHEVs in the French transportation fleet will depend on the actions ran by the government, the will of manufacturers to develop the corresponding products and the viability of business models developed for this purpose.

A 4.1.3.1 Government plan

The French government launched (in October 2009) a national plan for the deployment of PEVs and PHEVs in France. This plan contains key points centred on three axes:

- **The development of a strong and efficient industrial and research EV field**
 - **Research for sustainable mobility:** funding of pilot cases, systematically including EVs in new mobility solutions
 - **Industrial EV field:** creation of a “EV batteries” field, initiation of the EV market thanks to a public order of 100 000 vehicles and financial discounts when buying an EV
- **The anticipation and the development of a favorable environment for EV usages**
 - **Charging facilities development at home and at work:** possibility to use classic domestic plugs, charging terminals compulsory in car parks of new construction, facilitating regulation for the installation of charging terminals in

already existing buildings, facilitation and obligation of installation of charging terminals in working buildings car parks, etc.

- **Developing public charging facilities in public places:** European plug type normalization independent of the charging power, funding for helping cities developing their public charging station network, creation of a decision helping committee aimed at cities inviting tenders, etc.
- **Environmental issues:** assuring a non-fossil source of energy for the EVs electric needs (working force on EV peak demand shifting), recycling of the batteries and their elements

Concerning the charging facilities, a French senator, Louis Nègre, wrote a “green book” which gives technical and economical recommendations for an efficient development of charging facilities. The standardization and normalization of charging facilities will be an essential key point in the success of EV deployment.

A 4.1.3.2 State of the EV industry

The EV industry is composed of different type of industrials, the main one being car manufacturers, batteries manufacturer, and charging terminals manufacturers.

- **Car manufacturers**

A non-marginal commercial offer of EVs exists in France since autumn 2011 (about 10 car types). PEVs and PHEVs of all types (urban, family and commercial cars) are currently developed by the car manufacturers.

The developed cars feature distance is about 150 km. They do not all support the three recommended types of charges (normal, accelerated and fast).

Until now the car manufacturers have each developed their own battery slots for each car model. There is therefore one type of battery per car model.

- **Battery manufacturers**

The Lithium-Ion technology is the dominant technology in EV batteries solution. The French Electric Mobility community (AVERE France) lists 5 battery manufacturers.

- **Charging terminal manufacturers**

Several charging terminals manufacturers exist. AVERE provides a list of 18 manufacturers.

Even if the recommendations (of the “green book” notably) gives voltage and current level for the various charging schemes, or plug types, that should be respected; the various manufacturers play on the design, the ergonomics, the man-machine interface and other parameters in order to propose the best suited terminal depending on its location (home, work, public car park...).

A 4.1.3.3 Deployment models considered

In France the electric vehicle is a real chance to decrease the CO₂ emissions. In fact, in France the energy mix for the electricity sector, which is dominated by nuclear energy, does not produce much CO₂. It is one of the least polluting in Europe (with 90 g of CO₂ per kWh).

Below is provided a diagram showing the gas emissions of different kinds of vehicles (from hybrids to electric) depending on the electrical mix of the country.

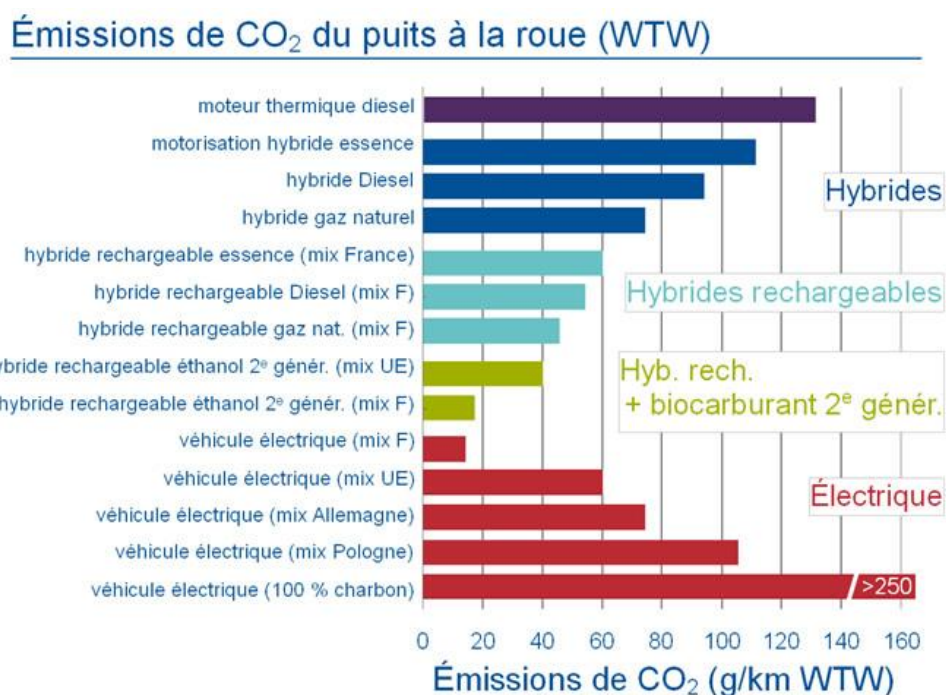

Figure A-34: CO₂ emitted (from “well to wheel”) by the different kind of vehicles in different countries
(Source: IFP⁴)

However one important problem is the cost of the battery. In fact today most of the batteries are lithium-ion batteries, but even if the technology is quite mature, the market is not yet fully established. Today the price of the battery represents 50% of the car price, according to the CRE⁵. That is why some car manufacturers are looking for solutions to launch the market.

For example, the French car manufacturer Renault has chosen a rent solution. Instead of buying an electric car with an expensive battery, the customer buy a car at a “normal” price but he rents a battery he pays every month for. The battery is chosen according to the number of kilometres made per year, and the monthly cost of rent depends on the wished- duration contract (between 12 and 72 months). According to Renault⁶, during all the period of the contract the customer can have a new battery (without paying more) in case of problem. Below there is an example of the price of rent for battery, for the *Fluence Z.E* car, depending on the contract terms:

⁴ : Smart grids CRE > Dossiers > Les véhicules électriques > Bilan carbone du véhicule électrique
<http://www.smartgrids-cre.fr/index.php?p=vehicules-electriques-bilan-carbone>

¹: smartgrids-cre >Dossiers >Les modèles économiques >L'exemple du véhicule électrique (page 5)
<http://www.smartgrids-cre.fr/index.php?rubrique=dossiers&srub=modeles&page=5>

⁶ : <http://www.renault-ze.com/fr-fr/gamme-z.e./zoe/renault-zoe-life-12.html>

Fluence Z.E (all taxes included) / annual kilometer				
Battery renting (with assistance)	10 000 km	15 000 km	20 000 km	25 000 km
Contract duration				
12 months	102 €	116 €	132 €	148 €
18 months	97 €	111 €	127 €	143€
24 months	92 €	106 €	122 €	138 €
30 months	87 €	101 €	117 €	133€
36 months				
48 months				
60 months	82 €	96 €	112 €	128€
72 months				

Table A-15: Rent batteries grid (Source: Renault) ⁷

According to the *Pike Research Institute*⁸, today, the cost of lithium-ion battery is around 603 € per kWh. In 2017 it should be about 398 € per kWh, only a third less than today...probably not enough to really launch the EV market.

It is also important to consider the environmental impact of those batteries. Below a certain threshold the battery is not available for a car use (at about 70% of its life span)⁹. The idea is to use the battery but for another application (second battery life).. Some tracks can be envisaged, for example for a UPS alimentation in hospitals, or to offset the intermittence of some renewable energies

Another difficulty is to know how the consumer will be paid for the service he gives to the grid. In fact a battery can be used as a storage device¹⁰ when the production is higher than the consumption: in this way, provide it is used at large scale with appropriate technology and business model, it helps the equilibrium production/consumption in the entire grid. Also if someone is charging his EV, he knows that the consumption (and so the production) is high

⁷ : <http://www.renault.fr/gamme-renault/vehicules-electriques/fluence-ze/fluence-ze/ze-battery/>

⁸ : <http://www.cnetfrance.fr/cartech/prix-batterie-voiture-electrique-39770542.htm>

⁹ : smartgrids-cre >Dossiers >Les modèles économiques >L'exemple du véhicule électrique (page 5) <http://www.smartgrids-cre.fr/index.php?rubrique=dossiers&srub=modeles&page=5>

¹⁰ : 3 Mars 2009, *Rapport n°1493 sur l'Evaluation de la stratégie nationale de recherche en matière d'énergie*, MM.Christian BATAILLE et Claude BIRRAUX http://www.assemblee-nationale.fr/13/rap-off/i1493.asp#P882_204351

and he decides to put back his charge. In addition, the owner of the EV can “offer” his battery as a source of electricity production. In this way he contributes to not start polluting power plants. For those services, the EV user has to be paid. But for the moment there is no rule and no regulation for this kind of services.

A 4.1.4 Technical impacts on the grid

A 4.1.4.1 Technical problems due to the insertion of EVs

The massive integration of EV is not without any consequence for the network. In fact one of the major problems of this deployment is the modification of the load profile. “The slow charging of 2 million of EVs simultaneously in France is equivalent of up to a 10% increase in national peak load”, according to EDF¹¹.

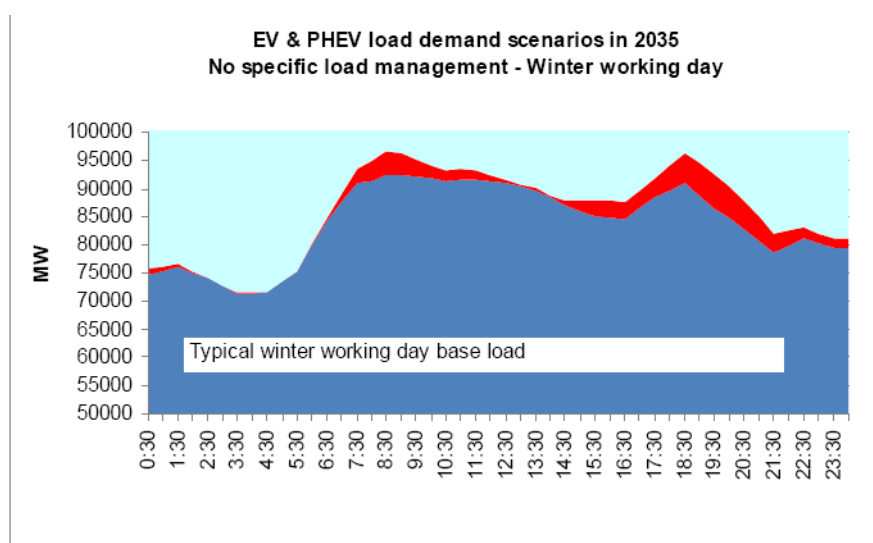

Free charge generates peaks at the beginning of the work period and in late afternoon till early evening



Figure A-35: National load profile with EV (no load management).

¹¹ : 25 Avril 2012, *The Inter project (Intégration du Transport Electrique dans le Réseau)*, Gaizka Alberdi (EDF R&D)

<http://www.ieadsm.org/Files/Tasks/Task%20XVII%20-%20Integration%20of%20Demand%20Side%20Management,%20Energy%20Efficiency,%20Distributed%20Generation%20and%20Renewable%20Energy%20Sources/Arnhem%20public%20workshop/Gaizka%20Alberdi%20-%20The%20INTER%20Project.pdf>

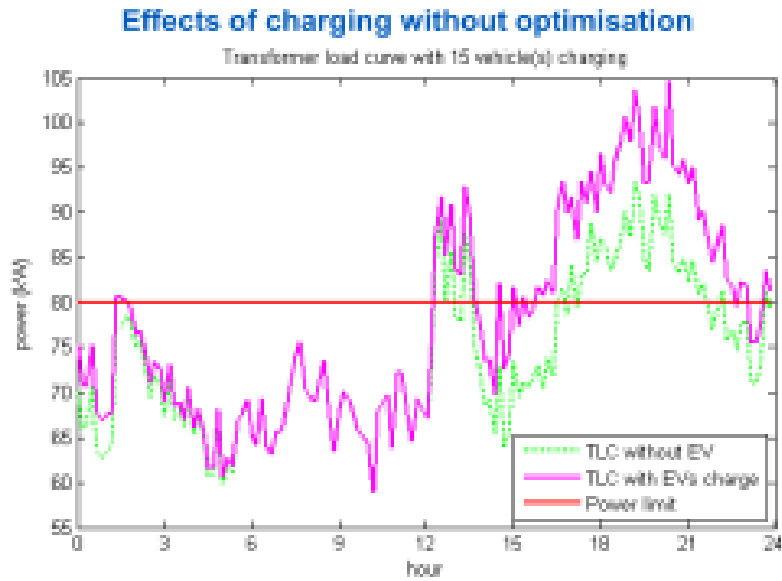

Figure A-36: Effects of charging without optimization.

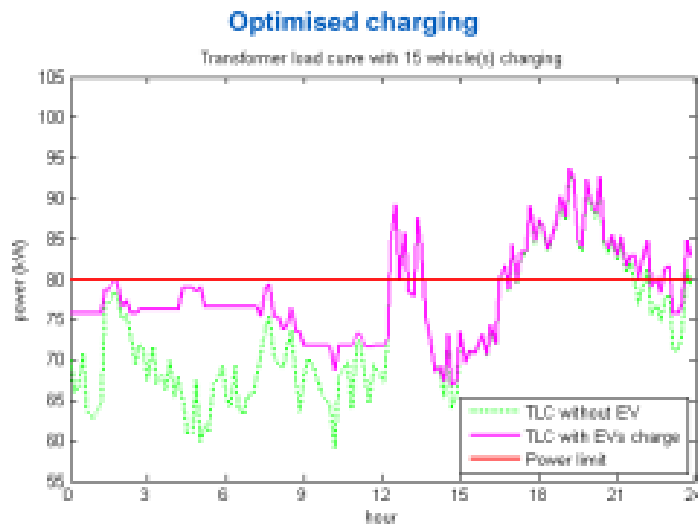

Figure A-37: Effects of charging with optimization.

As it is shown if there is no specific load management, the charges of electric vehicles will increase the peak periods. And so the means used for producing electricity will be more polluting than in off-peak periods...so the non polluting side of the electric vehicles is not ensured.

But the peak can also be mobile. In fact in some country sides the EV deployment will create some congestions and so technical losses but also a degradation in the power quality with maybe more frequent power cuts.

The second problem is directly linked with the power. In the opinion of EDF¹², the power quality will be affected because of the charge which creates perturbations on the grid when the power increases. It is possible to observe flickers and high harmonics. The power quality disturbances like flicker are due to interruptions in the charging process for battery management and harmonics are due to the AC to DC conversion. There are also high frequencies disturbances (in the range 2- 150 kHz) due to power electronic used in the charger.

A 4.1.4.2 Example of solutions

Some strategies have been found to avoid the problem of the peak increase. For example there are the off-peak charge management and the soft charge management (see the figures below).

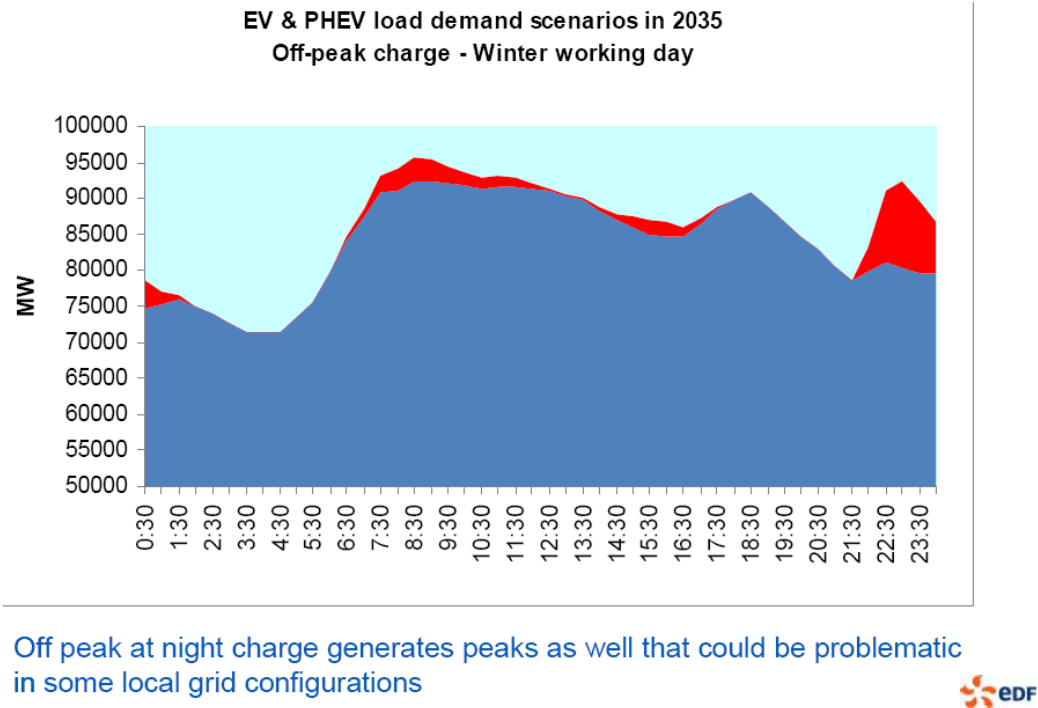
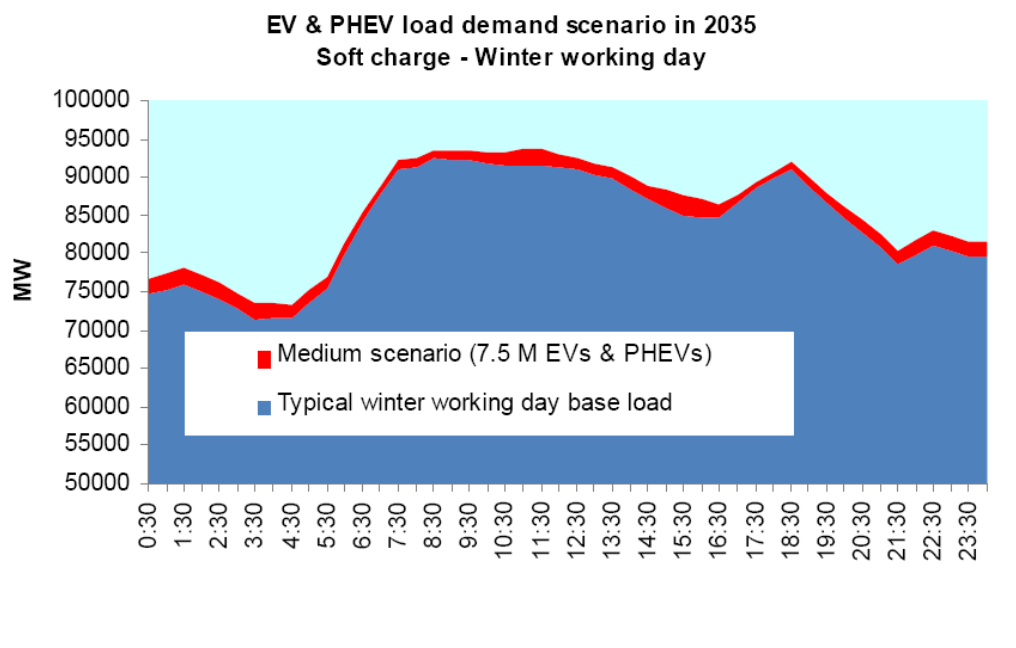

Figure A-38: Load profile with an off-peak charge

¹² : 25 Avril 2012, *The Inter project (Intégration du Transport Electrique dans le Réseau)*, Gaizka Alberdi (EDF R&D)
<http://www.ieadsm.org/Files/Tasks/Task%20XVII%20-%20Integration%20of%20Demand%20Side%20Management,%20Energy%20Efficiency,%20Distributed%20Generation%20and%20Renewable%20Energy%20Sources/Arnhem%20public%20workshop/Gaizka%20Alberdi%20-%20The%20INTER%20Project.pdf>



Soft charge is very efficient in getting rid off peaks
Soft charging EV appears as a steady load throughout the day



Figure A-39: Load profile with a soft charge

Those two load profiles are two among various possible load management scenarios. These results are not presented as a defined and precise solution but rather as an insight on the fact that load management will be strictly required (on a long-term and when EVs will be deployed on a large scale) in order to have a operational electric network.

For the problem of the mobile peak (geographically speaking), for the moment the unique solution is the local reinforcement of the grid.

To avoid as much as possible the problem of the power, the slow charging needs to be valorised. In fact the power needed for this kind of load is of 3kVA whereas for the fast and very fast one the power levels are respectively of 22kVA and 43kVA¹³.

A 4.1.5 Conclusion

Nowadays electrical vehicles are not enough developed to have a real impact on the grid. For the moment two major problems impede the deployment of EVs: the battery and the development of the reload infrastructures. In fact, even if some car manufacturers are trying to reduce the cost for the customer, it is still high. More of that, even if the batteries' autonomy has increased, today is difficult to drive more than 150 km with one reload. As a consequence, for the daily rides the EV is a good solution but not to travel for long distance. This will incite

¹³ : 25 Avril 2012, *The Inter project (Intégration du Transport Electrique dans le Réseau)*, Gaizka Alberdi (EDF R&D)

<http://www.ieadsm.org/Files/Tasks/Task%20XVII%20-%20Integration%20of%20Demand%20Side%20Management,%20Energy%20Efficiency,%20Distributed%20Generation%20and%20Renewable%20Energy%20Sources/Arnhem%20public%20workshop/Gaizka%20Alberdi%20-%20The%20INTER%20Project.pdf>

the customer to keep his thermal vehicle or to have two cars: one for the short trips, one for the long one. So the battery is a decisive issue for the EV deployment. In order to succeed a perennial deployment, the objective is to reach in 2020 the number of 2 million of electric vehicles¹⁴.

One important unknown is the charge management: how the users are going to employ their vehicles, when will they charge their batteries, the kind of charge they are going to use, etc. That is why some demonstration projects are devoted to analyze the users' behaviour to prepare the grid to a more significant insertion of EVs and to know what are the issues that need to be reviewed. Nevertheless there is a quasi-consensus on the fact that the batteries' charge needs to be smart, which means that the charge does not have to amplify the peak of the load profile or to exert stress on the grid. As it is shown on the examples of charge profiles above, the proper load and charge controls allow the reduction between 500 MW to 2 000 MW (depending on the control strategy) the morning peak and between 4 000 MW and 5 000 MW the evening peak.

Thus the debate is more on the *Vehicle to Grid*, the fact to use the car as a storage mean or as a production mean (depending on the moment of the day and the needs of the network). Today such use is not yet considered, but this model is one of the options for the deployment of electric vehicles.

Today the use of EVs is a real opportunity for the utilities but at the same time a huge challenge. It is essential to require a harmonized standardization and policies in order to have a better impact at the European level. For the business models it is necessary for the moment that the technical solutions remain simple and the cost optimal.

On one hand, the deployment of the EVs reinforces and encourages the development of the energetic efficiency on all the kind of vehicles (thermals, hybrids or electrics). These improvements of the energetic efficiency should be in competition with the development of the electric vehicles and so the transition to the electricity will be very progressive. The panorama of the car manufacturers should be totally changed.

But on the other hand it is also a good accelerator of thinking for city planning. The problem of the public reload stations should help to reorganize the scheme of the cities, in order to better welcome the smart-grids.

Today the deployment of the EVs seems to be directly linked with the evolution of the customer mind. The demand of electric vehicles and of reload devices should help to the deployment of electric vehicles.

A 4.2 *Involved stakeholders for system integration of smart meters*

A 4.2.1 *Introduction*

The smart meter is an energetic meter (for the moment mostly for the electricity), able to follow in details and in real time a residential and building consumption. For the moment in France only some pilot projects are using smart meters , in particular the *Linky project* (whom

¹⁴ : 20th June 2011, *Le véhicule électrique : Une sécurité maîtrisée en vue d'un déploiement pérenne de la filière – L'état d'avancement des travaux au 20 Juin 2011*, le Ministère de l'écologie, du développement durable, des transports et du logement.

<http://www.developpement-durable.gouv.fr/IMG/pdf/avancement-des-travaux-au-20-juin-2011.pdf>

objectives are described in section A 4.2.2). This kind of technology is not yet a generalized one. The smart metering plays an important role in the deployment of the smart grids. It is the first step of the demand side management (DSM) but also in the development of the open access, settled since the energy market liberalization.

With the massive integration of decentralized generations and renewable energies, the grid operators have to adapt the networks in order to make them smarter. Thanks to the smart meters it should be possible to manage even better the energetic flows between production and consumption sources particularly at the distribution level by enhancing its observability.

Thus, the challenge is more for the Distribution System Operators (DSO) than for the Transmission System Operator (TSO) because the transmission grid is already well equipped with all kind of sensors. Below, it is possible to see the integration of the smart-metering in the smart grids scheme:

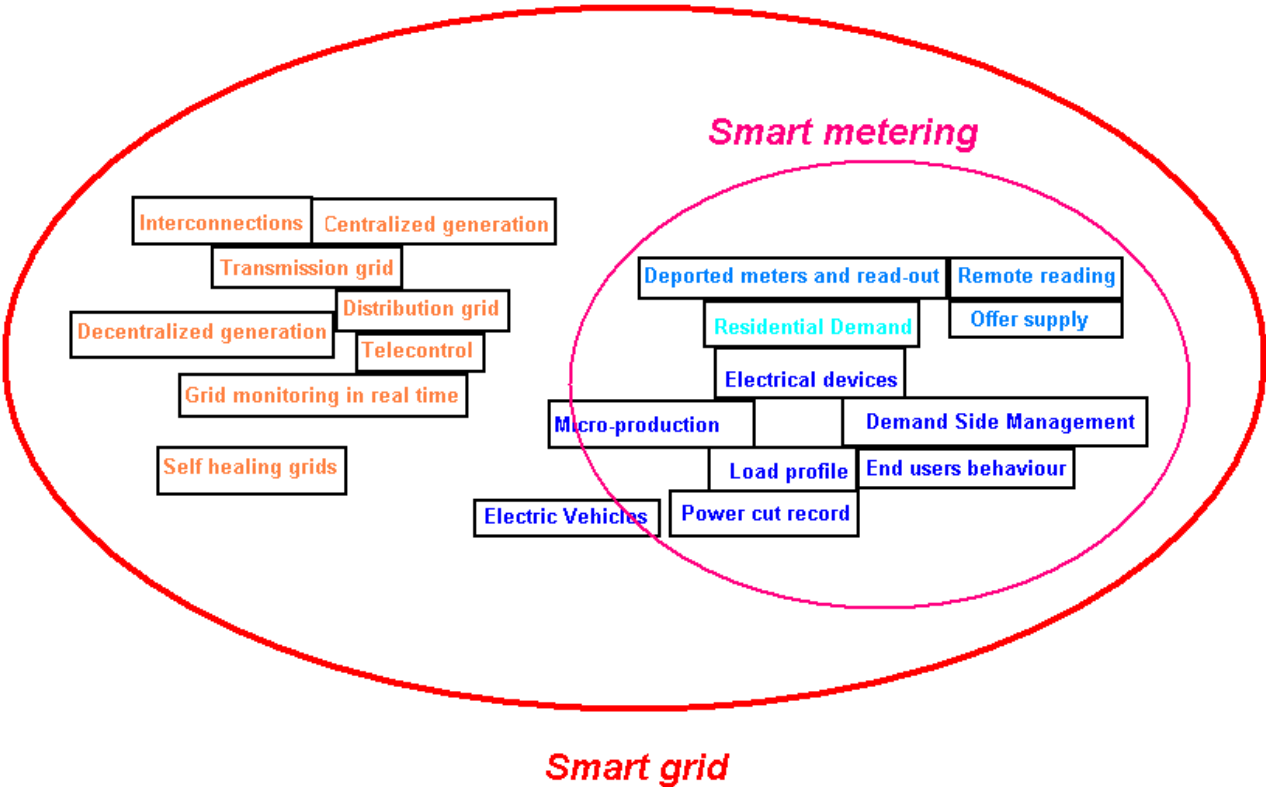

Figure A-40: Smart grid scheme (Source: CRE¹⁵)

Of course the smart metering deployment enrolls in the context of the reduction of CO₂ emission, and of the massive insertion of renewable energies but also for the reduction of the electrical bill of the end-user.

¹⁵ : Smartgrids-CRE > Dossiers > Les compteurs évolués
<http://www.smartgrids-cre.fr/index.php?p=compteurs>

A 4.2.2 The different stakeholders and their roles

In order to show the different stakeholders and their interaction, the most concrete was to explain it through the recent experimentation of *Linky*. The *Linky* smart-meter project is an ERDF project, involving end-users of Lyons and its suburbs and the county of Indre-et-Loire (a rural zone). The installation phase of the project began in March 2010 with the putting in of the smart meters. Around 300 000 had to be installed.

If this project is assessed feasible by the different authorities, then it should be generalized to 35 million households. The main objective of this development is to reduce the exploitation cost and so the electrical bill of the end-users, but also to develop the energy market (with more energy suppliers and more offers). Below there is a presentation of the different stakeholders of the smart meter through the example of the *Linky* project.

The stakeholders can be divided into two parts: the institutions and the industrials. The institutions give the right to the DSO to operate under the law and the industrials give to the DSO the technologies to succeed its mission.

A 4.2.2.1 Institutions

European Commission

*“The European Commission is one of the main institutions of the European Union. It represents and upholds the interests of the EU as a whole. It drafts proposals for new European laws. It manages the day-to-day business of implementing EU policies and spending EU funds.”*¹⁶. In this Commission there is a special commissioner in charge of the Energy department.

Role in the smart metering deployment:

Since the 31st March 2004¹⁷ (date of the first directive 2004/22/CE concerning the smart-metering) the European Commission does not stop being involved in the smart-metering deployment. The commissioners wrote directives in order to encourage the European countries to develop smart metering technologies¹⁸.

The 5th April 2006, the European Commission wrote the directive 2006/32/CE¹⁹ on the energy efficiency for the end-uses and energetic services.

¹⁶ : Europa.eu > Home > Institutions and Bodies > European Commission
http://europa.eu/about-eu/institutions-bodies/european-commission/index_en.htm

¹⁷ : 30 Avril 2004, *Journal Officiel de l'Union européenne*, Directive 2004/22/CE du Parlement européen et du Conseil du 31 Mars 2004 sur les instruments de mesure
<http://www.industrie.gouv.fr/metro/reglemen/textes/mid.pdf>

¹⁸ : Smartgrid-CRE > Dossiers > Compteurs évolués > Introduction
http://www.smartgrids-cre.fr/media/documents/dossiers/compteurs/Le_contexte_reglementaire_du_developpement_des_compteurs.pdf

¹⁹ : 27 Avril 2006, *Journal Officiel de l'Union européenne*, Directive 2006/32/CE du Parlement européen et du Conseil du 5 Avril 2006 relative à l'efficacité énergétique dans les utilisations finales et aux services énergétiques
<http://eur-lex.europa.eu/LexUriServ/LexUriServ.do?uri=OJ:L:2006:114:0064:0064:fr:pdf>

The 13th July 2009, the directive 2009/72/CE about the shared rules for the domestic electricity market²⁰ has been made public.

The 9th March 2012, some directives have been made for the launch of the smart metering systems²¹. They are about the security and the data protection, the methodology for the economic assessment of the long-term costs and benefits for the roll-out of smart metering systems and the common functional requirements for smart metering systems for electricity. The 27 European member states have to adopt and to follow those recommendations. The European Commission is the first entity to pronounce the goals to reach.

The French Government

The first step for the French Government is to transpose the European Directive in French Rights. For example the decrees n° 2001-387 of the 3rd May 2001 and n°2006-447 of the 12th April 2006 transposed the directive 2004/22/CE of the 31st March 2004²².

The French Government is the only national entity who has the power to decide of the application of a new technology. Without its agreement the development of the smart meter is not expected. It is in charge to apply the directives given by the European Commission.

Role in the smart metering deployment:

The Ministry of the Ecology, Sustainable Development, and Energy is in charge of the smart metering deployment. Year after year the French Government wrote laws and decrees in order to help the deployment of the smart-metering. According to the French regulator, the CRE, the important steps were²³:

- the transposition of the European directive 2004/22/CE of the 31st March 2004 in two decrees n° 2001-387²⁴ and n° 2006-447²⁵. The 28th April 2006 an Order (resulting from those two decrees) gives the ability for a power-meter to furnish the power counting of course, but other functions too.

²⁰ : 14 Août 2009, *Journal Officiel de l'Union européenne*, Directive 2009/72/CE du Parlement européen et du Conseil du 13 Juillet 2009 concernant des règles communes pour le marché intérieur de l'électricité
<http://eur-lex.europa.eu/LexUriServ/LexUriServ.do?uri=OJ:L:2009:211:0055:0093:FR:PDF>

²¹: 13th March 2012, *Official Journal of the European Union*, Commission Recommendation of 9 March 2012 on preparations for the roll-out of smart metering systems
<http://eur-lex.europa.eu/LexUriServ/LexUriServ.do?uri=OJ:L:2012:073:0009:0022:EN:PDF>

²² : CRE > Réseaux > Réseaux publics d'électricité > Comptage électrique > Textes réglementaires
<http://www.cre.fr/reseaux/reseaux-publics-d-electricite/comptage-electrique>

²³ : CRE > Réseaux > Réseaux publics d'électricité > Comptage électrique > Textes réglementaires
<http://www.cre.fr/reseaux/reseaux-publics-d-electricite/comptage-electrique>

²⁴: Décret n° 2001-387 du 3 Mai 2001 relatif au contrôle des instruments de mesure
http://www.legifrance.gouv.fr/affichTexte.do?sessionId=35215A4F1D89434F394F0CF52726A1C2.tpdjo08v_3?cidTexte=LEGITEXT000005630926&dateTexte=20100228

²⁵ : Décret n°2006-447 du 12 Avril 2006 relatif à la mise sur le marché et à la mise en service de certains instruments de mesures
<http://www.legifrance.gouv.fr/affichTexte.do?cidTexte=JORFTEXT000000423249&dateText>

- The articles L.341-4²⁶ and 322-8²⁷ of the Energy Code allowing the DSOs and TSOs to establish ways for the energy suppliers to propose different tariffs for the end-users depending on the hour of the day and the moment in the year, and charging the DSO of the metering.
- The law n°2009-967 of the 3rd August 2009²⁸, asking for the generalization of the smart meters in order to reach the aims of the Environment Grenelle.
- The law n° 2010-788 of the 12th July 2010²⁹, following the Grenelle II and asking to the energy suppliers to communicate periodically the energetic consumption to the end-user with comparative elements and advices in order to make him reduce his consumption.
- The decree n°2010-1022 of the 31st August 2010³⁰, specifying the role of the different stakeholders (the experimentation for ERDF, the evaluation of this experimentation for the CRE and the decision for the generalization for the Government).
- The Government wrote the 4th January 2012³¹ an Order describing the functionalities expected by a smart-meter.

The power level in our case is less or equal to 36 kVA. The articles 4, 5 and 6 of this order, declare that the smart meters have to:

- measure and record the active power and the decanting curves by steps of time of 10, 30 or 60 minutes
- the maximal value of decanted power.

²⁶ : Code de l'énergie > Partie législative > Livre III : les dispositions relatives à l'électricité > Titre IV : l'accès et le raccordement aux réseaux, article L.341-4

http://www.legifrance.gouv.fr/affichCode.do;jsessionid=499B7C06EC709516850DB0AB780FAE33.tpdjo16v_2?idSectionTA=LEGISCTA000023986724&cidTexte=LEGITEXT000023983208&dateTexte=20110816

²⁷ : Code de l'énergie > Partie législative > Livre III : les dispositions relatives à l'électricité > Titre I : le transport et la distribution > Section 1, article L.322-8

http://www.ineris.fr/aida/?q=consult_doc/consultation/2.250.190.28.4.14972/docoid=2.250.190.28.8.14970

²⁸ : Loi n°2009-967 du 3 août 2009 de programmation relative à la mise en œuvre du Grenelle de l'environnement

http://www.legifrance.gouv.fr/affichTexte.do;jsessionid=7BFFA2CB5838CE9A50F2224080027618.tpdjo14v_1?cidTexte=JORFTEXT000020949548&categorieLien=id

²⁹ : Loi n°2010-788 du 12 juillet 2010 portant engagement national pour l'environnement (1)

<http://www.legifrance.gouv.fr/affichTexte.do?cidTexte=JORFTEXT000022470434>

³⁰ : Décret n°2010-1022 du 31 août 2010 relatif aux dispositifs de comptage sur les réseaux publics d'électricité en application du IV de l'article 4 de la loi n°2000-108 du 10 février 2000 relative à la modernisation et au développement du service public de l'électricité

<http://www.legifrance.gouv.fr/affichTexte.do?cidTexte=JORFTEXT000022765140>

³¹ : Arrêté du 4 janvier 2012 pris en application de l'article 4 du décret n°2010-1022 du 31 août 2010 relatif aux dispositifs de comptage sur les réseaux publics d'électricité

http://www.legifrance.gouv.fr/affichTexte.do;jsessionid=0AFB4217EF47400D9D8D85D2EB758569.tpdjo02v_1?cidTexte=JORFTEXT000025126353&dateTexte=20120612

For an installation where there is electricity production, the smart meter needs to be able to measure and record the active power and the injection curves for the same steps of time, and also the maximal value of the power injected.

The smart meter should be able to show the calendar of the TURPE (utilization tariff of the electric public grids) in decanting, for at least 4 different tariff classes, to allow the energy supplier to define and purpose his own tariffs with at least 10 different classes of tariffs. Thanks to the smart meter it will be possible to change the power level of the contract, and the remote connection and the disconnection of the end user. One contact needs to be controllable with at least one of the tariff calendar. Every smart meter will have a local interface of electronic communication showing the instantaneous power, one (or more) indication of the tariff period and the indication of the current tariff period, the index for the tariff calendars, elements of the measure curves, the value of the maximal decanting power and the maximal injected power, the whole accessible by the user. The smart meter will also record the disconnections. The interoperability is one of the functionalities of the smart meters as well, that is to say that the smart meter is able to communicate with other devices and to exchange the data.

The sixth article of the Order declares that the counting data recovered by the DSO are shared with the energy suppliers and the Balance Responsible Entity. As well, the TSO or/and the DSO have to give to the consumers a technical documentation suggesting the best consumption periods.

Also the ADEME³², a public agency under the authority of the Ministry of Ecology, Sustainable Development and Energy, has to encourage, supervise, coordinate, facilitate and undertake operations with the aim of protecting the environment and managing energy. This public agency has an important role in the deployment of the smart-metering and smartgrids in general.

For example the ADEME, in collaboration with the Ministry of Ecology, Sustainable Development and Energy, has issued in 2011 a call for expression of interest for the deployment of the Smart Grids³³. This call was in two different parts: one for projects for the development of new equipments or services helping to solve technological problems, and the other for pilot projects to test the real impact of the new technologies and the new business models of the grid global efficiency.

Through the *Linky* project, the ADEME gave some advices or expertise, not to judge the technological aspect of the smart-meter but more the economic and the ecological aspects: if there is a real economy of energy, a decrease of carbon emissions, and the impact for the integration of renewable energies³⁴. As a conclusion of this report (³), the ADEME considered it was essential for the end-users to have a free access to their consumption data.

In agreement with the regulator (whose role is explained later), and after the experimentation, the Government decided in September 2011, to generalize the *Linky* smart meters³⁵.

³² : French Environment and Energy Management Agency (Agence De l'Énergie et de la Maîtrise de l'Énergie)

³³ : <http://www2.ademe.fr/servlet/getDoc?id=77471&cid=96&m=3&p1=1>

³⁴ : «*Le compteur Linky* » *Analyse des bénéfices pour l'environnement*, 22 Novembre 2011, ADEME

³⁵ : 28 Septembre 2011, Communiqué de Presse de ERDF
http://www.erdfdistribution.fr/Communique_presse_ERDF_detail?actuId=278

Local authorities

In France the local authorities, such as cities and municipalities, are also involved in the electricity distribution grids as a stakeholder. They are the owners of the distribution grid infrastructures.

Most of them delegate to the DSO ERDF, the control of the distribution grid infrastructures³⁶. In this way ERDF operates 95% of the French distribution grid. Most of these contractor authorities are grouped together in FNCCR (French National Federation of Contractor authorities and local companies). The other 5% are covered by ELD: local electricity companies³⁷. In France there are around 170³⁸ ELD present in all the territory notably in the regions of Alsace, Centre, Gironde, Lorraine, and Rhône-Alpes³⁹.

In all cases the grid infrastructures belong to the contractor authorities (local authorities or group of local authorities).

Role in the smart metering deployment:

Nowadays, the local authorities own the meters for the electricity. They are the owners of the distribution grid infrastructures.

Regulator

“CRE is an independent administrative authority created by the law of 10 February 2000. CRE regulates the energy sector in France.”⁴⁰

“CRE contributes to the smooth operation of energy markets for the benefit of the consumer.”⁴¹

“Under the provisions of the Code of energy, which clarified the European directives concerning the European Internal Market of electricity and gas, CRE has powers which are traditionally devolved for independent administrative authorities responsible for regulating a market or a sector open to competition characterized by the presence of public operators:

- *Powers of decision, approval or authorisation (system operators, contribution to the public electricity service, etc.)*
- *Dispute settlement and sanctions relative to access to the electricity and gas networks (CoRD*i*S)*
- *Powers of proposal (tariffs for the use of public electricity grids, contribution to the public electricity service, etc.)*
- *Information and investigative powers with stakeholders*
- *Advisory powers (tariffs, regulated access to incumbent nuclear electricity, etc.)*

³⁶ : ERDF distribution > Profil

<http://www.erdfdistribution.fr/Profil>

³⁷ : http://www.erdfdistribution.fr/erdf_et_les_entreprises_locales_de_distribution

³⁸ : Février 2012, *Tableau de bord éolien photovoltaïque*, Commissariat Général au développement durable <http://www.developpement-durable.gouv.fr/IMG/pdf/CS293.pdf>

³⁹ : Répertoire des entreprises locales de distribution d'électricité et de gaz <http://www.repertoire-eld.com/accueil.asp>

⁴⁰ : <http://www.cre.fr/en/presentation/status>

⁴¹ : <http://www.cre.fr/en/presentation/missions>

➤ *Additional power (processing of tenders for electricity generation)* ⁴²

Role in the smart metering deployment:

The CRE is especially in charge of the elaboration of the requirements for the *Linky* project, but also of the pre-evaluation of this project.

For the *Linky* smart meter more specifically, the CRE has made some orientations about the metering. In June 6th, 2007 communication⁴³, the CRE asked the French DSO, ERDF, to achieve experimentations before a smart meter generalization.

At the issue of the *Linky* experimentation, the CRE has made some recommendations⁴⁴.

The CRE is an important stakeholder for the deployment of the smart-metering. This entity wrote a lot of communications and deliberations on the subject, in order to advance the different regulations and legislative texts⁴⁵.

The first press review of the CRE on the subject dates from the 27th November 2000. The CRE asked the DSOs to ensure the access for the end-users, for the metering of their consumption. Then the CRE made some communications July 5th, 2001, January 29th, 2004 and June 6th, 2007 respectively on:

- The access conditions of the metering data
- The electrical counting and its specifications
- And on the evolution of the electrical counting low voltage and low power and its orientations.

Then the regulator suggested a proposition for February 12th, 2009 decree about the implementation of the smart-metering.

After that the CRE made four deliberations:

- The 11th February 2010, on the technical criteria that will be used for the evaluation of the ERDF experimentation
- The 30th March 2011, to say that the CRE is able to measure the conformity of the smart-meter with the functionalities decided on June 6th, 2007.
- The 7th July 2011, to communicate the results of the *Linky* experimentation.
- The 10th November 2011, to propose a suggestion for an Order on the smart meters on the public electrical grids. It is an order project for the application of the article 4 of the decree n° 2010 1022 of the 31st August 2010.

⁴² : <http://www.cre.fr/en/presentation/powers>

⁴³: Communication de la CRE du 6 Juin 2007 sur l'évolution du comptage électrique de basse tension de faible puissance > Consulter la communication
<http://www.cre.fr/documents/%28text%29/+6+juin+2007>

⁴⁴ : 7th July 2011, Deliberation of the CRE, available for consultation on:
<http://www.cre.fr/documents/deliberations/%28text%29/linky>

⁴⁵ :CRE communications and deliberations
<http://www.cre.fr/reseaux/reseaux-publics-d-electricite/comptage-electrique>

The issue of the experimentation has been conclusive, and so the CRE suggested the generalization of the *Linky* project for 35 million of users.

N-B: As a comment, for the Smart Grid, it has created a special website⁴⁶ where the actors concerned by the subject can write to inform about the works advancement

A 4.2.2.2 Industry stakeholders

The interactions between the different stakeholders can be summarized as it is shown on the diagram below:

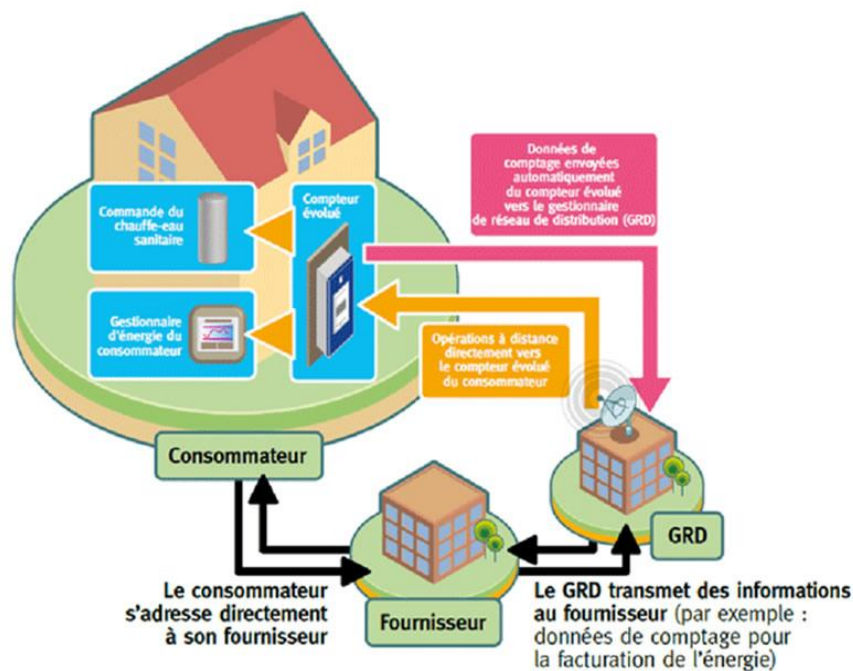

Figure A-41: Interactions between some stakeholders (Source: CRE⁴⁷)

The interactions described are between three important stakeholders: the DSO, the end-user and the energy supplier. Thanks to the smart-meter installed within the end-user home, the DSO and the energy supplier can be informed in quasi real time of the end-user consumption. The metering data are automatically sent to the DSO. In this way, depending on the real time national consumption, the DSO can send signals to the smart meter for possible limiting the house consumption. The smart meter questions the devices connected to itself (for example the hot water tank, the washing machine etc.). Also with the new meter it is easier for the DSO to make some maintenance operations and diagnosis remotely. Then between the DSO and the energy supplier there are data transmissions, for example for the energy invoicing with the real data. The relation between the energy supplier and the end-user is simplified and now the consumer just has to call his energy supplier if he wants to change his standing charge.

⁴⁶: www.smartgrids-cre.fr

⁴⁷: <http://www.cre.fr/reseaux/reseaux-publics-d-electricite/comptage-electrique>

DSO

The DSOs are in charge of the distribution of the electricity to medium voltage and low voltage customers (industrial or residential). In France, one main historical DSO (ERDF) operates 95% of the distribution system⁴⁸. The 5% remaining are shared by about 170 small and local DSOs (called Local Distribution Operator) hold, most of the time, by the municipalities. The DSOs do not own the distribution network but share, with the cities and local communities, the investments costs. The seven most important French DSO are⁴⁹: ERDF, of course, Electricité de Strasbourg, Gaz et Electricité de Grenoble, UEM, SICAIE de l'Oise, Gérédis Deux-Sèvres, and SRD and represent 98% of the French distribution grid.

Role in the smart metering deployment:

In France, the DSO is the only responsible for the metering⁵⁰. Especially, ERDF is in charge of the *Linky* project and has to work according to the specifications of the regulator for the deployment of this project.

ERDF developed, made some industries manufactured the smart meter, and experimented *Linky* smart meters.

According to the specifications of the CRE, ERDF experimented *Linky* smart meter as a tool for the energy market and end-user information.

In addition, ERDF developed a specific research project to experiment the *Linky* smart meter as a tool for the advanced operations of the distribution grid.

End-users

The end-users are listed in four different types: the huge non residential, the medium non residential, the small non residential and the residential sites. The energy market is shared between these four categories and as it is shown in the following diagram they did not have all neither the same consumption nor the same number of sites:

⁴⁸ : <http://www.erdfdistribution.fr/Profil>

⁴⁹ : 1er trimestre 2011, *Observatoire des marchés de l'électricité et du gaz*, CRE

⁵⁰ : Code de l'Energie > Titre II : Le transport et la distribution > Chapitre II : la distribution > Section 2 : les missions du gestionnaire du réseau de distribution, article L 322-8
http://www.ineris.fr/aida/?q=consult_doc/consultation/2.250.190.28.4.14972/docoid=2.250.190.28.8.14970

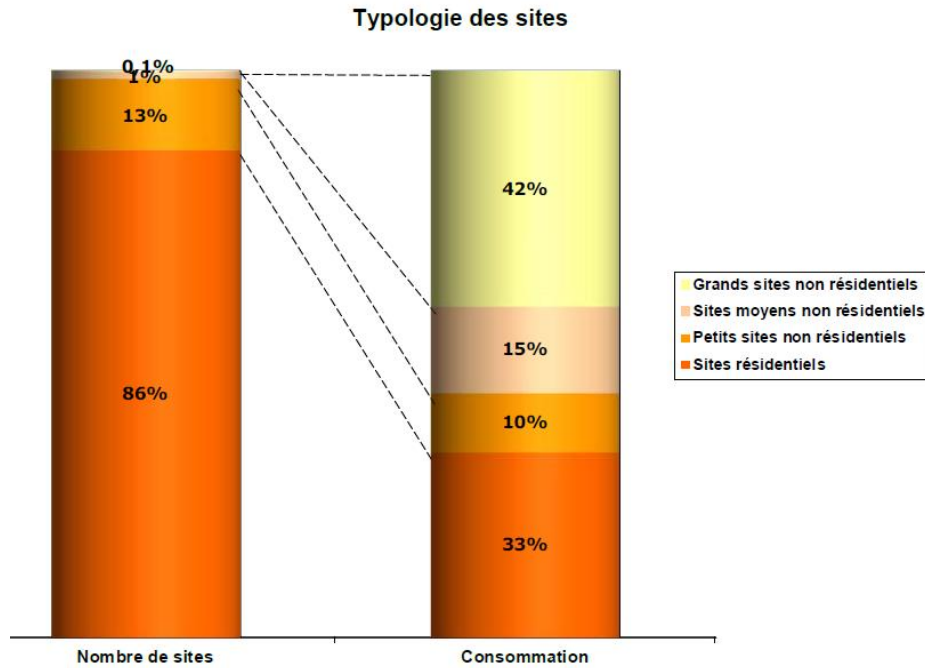

Figure A-42: Typology of the different sites (number of sites in function of their consumption)
(Source: CRE ⁵¹)

The huge non-residential sites represent the large industrial sites, the hospitals, the hypermarkets, etc. The rated power is equal or greater than 250 kW.

The medium non-residential sites have a rated power between 36 and 250 kW. Those two kinds of non-residential are not concerned by the *Linky* experimentation. The small non-residential sites regroup the liberal professions, artisans, etc. As for the residential sites, the rated power does not exceed 36 kVA

The non residential sites represent more than the two third of the electric consumption but only 14% of the number of sites whereas the residential end users represent 86% of the sites number but only a third in consumption.

⁵¹ : *Observatoire des marchés de l'électricité et du gaz – 1^{er} trimestre 2012*, CRE
<http://www.cre.fr/marches/observatoire-et-indicateurs-des-marches>

	Residential sites	Non Residential sites
Number total of sites	30 677 000	4 921 000
Regulated tariffs sites	28 756 000	4 235 000
Market offer sites	1 921 000	686 000
→ Historic energy suppliers	11 000	316 000
→ Alternative energy suppliers	1 910 000	370 000
Market share of alternative Suppliers	6.2 %	7.5%

Table A-16:- Repartition of the sites between the different suppliers (Source: CRE ⁵²)

Since the liberalization of the energy market the 1st July 2007, the residential and non residential end-users can choose the energy supplier they want. There are two types of offers: regulated tariffs or prices of market offers. The historic suppliers are allowed to propose the two options, but the alternative suppliers have to content themselves with the second option. Even if the large majority of the end-users prefer to stay with a regulated tariff (93% for the residential, and 86% for the non-residential) and so with the historic supplier, for the market offers the end-users tend to prefer the alternative supplier to the historic one. In fact for the non-residential there is not a lot of difference between the number of sites with historic energy suppliers and alternative one but for the residential sites it is different. Indeed the number of consumers of alternative suppliers is about two hundreds times more important than for the historic one.

⁵² : *Observatoire des marchés de l'électricité et du gaz – 1^{er} trimestre 2012*, CRE
<http://www.cre.fr/marches/observatoire-et-indicateurs-des-marches>

Répartition des sites par type d'offre au 31 mars 2012

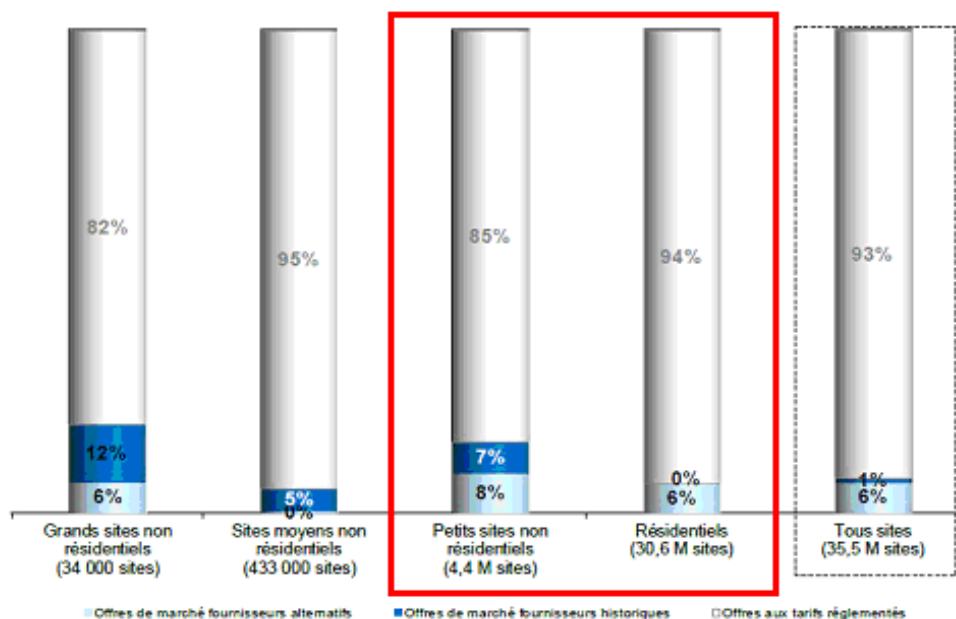

Sources : GRD, RTE, Fournisseurs historiques – Analyse : CRE

Figure A-43: Sites' share by kind of offers (31st March 2012)
(Source: CRE⁵³)

For the smart metering deployment the end-users concerned are the small non-residential sites and the residential sites. Nowadays the alternative suppliers do not represent the most important part of the choice of small non-residential sites and residential sites. With the Linky smart-meter deployment this part should be more important than today...

Role in the smart metering deployment:

Today, according to ERDF⁵⁴, there are 35 million of end-users. They are the heart of the project. Without their agreement, their motivation and their actions, a Smart grid project is not possible. Consumers will become actors of their consumption but also of their production. For example the electricity delivered by their photovoltaic panels will be employed to charge their EV battery.

According to the *Linky Experimentation File*⁵⁵ made by the CRE, the 30th June 2011, 245.228 smart meters of around 270.000 had been installed. The aim is to install from 2013, 35 million of smart meters in France.

Through this project, consumers, DSO and energy suppliers will know precisely the consumption in quasi real-time. So thanks to the smart metering, the consumer should have an

⁵³ : Observatoire des marchés de l'électricité et du gaz – 1^{er} trimestre 2012, CRE
<http://www.cre.fr/marches/observatoire-et-indicateurs-des-marches>

⁵⁴ : <http://www.erdfdistribution.fr/Profil>

⁵⁵ : CRE > Documents > Délibérations > Dossier sur l'expérimentation Linky
<http://www.cre.fr/documents/deliberations/%28text%29/linky>

active control of his consumption. He should be able to optimize his electric consumption better than today.

With the problem of the ownership of the data transfer every 10 minutes, the CNIL⁵⁶ (National Commission for Privacy “*is responsible for ensuring that information technology remains at the service of citizens, and does not jeopardize human identity or breach human rights, privacy or individual or public liberties*”⁵⁷) is involved in the *Linky* project. For the security of the end-user and for the confidentiality of the data treated, the CNIL asked for a technical audit from the ANSSI (French National Authority for the Security of Information Systems). This obligation includes counting the input and output communications.

With the deployment of the smart-metering, end-users would be able to participate to the energy market by choosing their energy supplier, their electricity standing charge and the tariff adapted to their needs. In fact they will be better informed of the electrical flows.

For the success of the *Linky* smart-meter, the end-user will have to use the competition between the different energy suppliers, but also to accept to “play the game” of the power cuts.

Energy suppliers

Energy providers in the usual French electricity market are often also retailers. But they provide other services than just “selling” electricity. Other services can be, for example, consumption diagnosis tools, help in energy management... These services can be useful for high energy consumer industrials.

Role in the smart metering deployment:

They will be informed in real time of the consumption of their end-users. In a smart grid configuration they should be able to modulate by them-selves the electricity consumption (or specify the way it should be done automatically). In this way, in a peak period - reducing the consumption- the polluting power plants should not be started⁵⁸. The smart-meter *Linky* will allow having 10 different indexes for the energy suppliers. Every 30 minutes they will be measured and accessed remotely every day. This functionality will give more tariff possibilities for the energy suppliers, and so they will be able to build offers and services better adapted to the end-users needs⁵⁹.

⁵⁶ : 8 Mars 2012, *Protection des données*, Armand Heslot (CNIL)

http://www.inria.fr/content/download/14931/479109/version/2/file/RII-CNIL_protection+des+donnees.pdf

⁵⁷ :CNIL website > The CNIL

<http://www.cnil.fr/english/the-cnil/>

⁵⁸ : Smart grids CRE > Présentation > Editorial > Edito de Michael Ohana (IBM) (page 5)

<http://www.smartgrids-cre.fr/index.php?rubrique=presentation&srub=edito&page=5>

⁵⁹ : Smart grids CRE > Dossiers > Les compteurs évolués > Les caractéristiques du comptage évolué en électricité (page 2)

<http://www.smartgrids-cre.fr/index.php?rubrique=dossiers&srub=compteurs&page=2>

The national energy suppliers are divided into two categories: one for the residential end-users and the other for non-residential end-users. The 31st March 2011 the active⁶⁰ electricity suppliers were⁶¹:

- Alpiq Energie, Direct Energie, Edenkia, E.ON Energie, Enercoop, EGL, Endesa Energia, Enel France, Energem, GDF Suez, Lampiris, HEW Energies, Iberdrola, Oddo Power, Planète UI, Poweo, SNET, Alterna, EDF, GEG Source d'Energies for the **non residential offers**
- Direct Energie, Enercoop, Energem, GDF Suez, Lampiris, Planète UI, Poweo, Alterna, EDF, GEG Source d'Energies for the **residential offers**.

The deployment of the smart meter involves for the energy suppliers to use the consumption/production data of the end-users given by the DSO, to adapt and vary their tariff offers.

Technology suppliers

Role in the smart metering deployment:

There are 3 different kinds of technology suppliers:

- *The firms manufacturing the Linky smart meter:*
 - Landis&Gyr, Itron, Iskrameko
 - ATOS Origin
- The firms offering technological solutions to develop the energy management in the end-user house thanks to the Linky meter:
 - Schneider Electric, Sagemcom...
- The firms suggesting technological solutions to develop an advanced supervision of the grid thanks to Linky:
 - Schneider
 - manufacturers joined in G3-PLC Alliance⁶²: ENEXIS, EDF R&D, Sagemcom, Texas Instrument, Maxim, Landis&Gyr, Itron, Nexans, Trialog, Cisco and St Micro.

The DSO, ERDF required some firms to make the Linky project feasible, technologically speaking. As it is written just above among them there are: SAGEMCOM, ATOS, LANDIS&GYR, ITRON, ISKRAMECO, and SCHNEIDER ELECTRIC.

The creation chain can be decomposed as follows (according to Atos Origin⁶³):

⁶⁰ : « active » means that the energy supplier has at least one unique contract with one site, or he is Balance Responsible Entity of one site at least, or he is Balance Responsible Entity and has delivered a part of a site consumption during the last trimester.

⁶¹ : Premier trimestre 2011, *Observatoire des marchés de l'électricité et du gaz*, CRE (page 11)

⁶² : 4 Octobre 2011, Communiqué de presse d'ERDF : *Courant Porteur en Ligne « nouvelle génération »*
http://www.erdfdistribution.fr/medias/communiqués_presse/CP_ERDF_041011_1.pdf

⁶³ : 28 Avril 2011, Communiqué de Presse d'Atos : *Atos Origin démontre des offres innovantes de Maîtrise de l'Energie pour enrichir les compteurs intelligents Linky d'ERDF*,
http://fr.atos.net/fr-fr/actualites/communiqués_presse/2011/2011_04_28_05.htm

- A demonstrator gatherer created by ERDF but made by the French industry “*Creative Eurecom*”. Thanks to this device it is possible to gather the data in a computer and to see them.
- A **Schneider Electric** Zigbee system including a transmitter into the *Linky* smart meter (in order to create a domestic grid to communicate in real-time with the house equipments), a receiver/ transmitter allowing the end-user to see his consumption in real-time via a display, and also a smart receptacle connected to the transmitter allowing to operate the connected equipments by remote control in real-time.
- A **Landis & Gyr** smart receptacle connected with power line communication (PLC) technology to a *Linky* hub allowing operating a connected device to this receptacle-device by remote control. The use of this kind of receptacle will depend on the regulations.
- An **Atos Origin** application allows the read-out of the consumption, the production or the electrical data comparison with the neighbourhood, on the Internet (on a computer, or via a Smart phone).

Atos Origin succeeded to build a decentralized data system thanks to its partners **Landis&Gyr** but also **Itron and Iskrameko**⁶⁴.

According to a press release of **SAGEMCOM**⁶⁵, after the success of the PLC-G1 technology on the first step of the *Linky* project, ERDF asked SAGEMCOM to work in the PLC-G3 technology based on the OFDM and IPV6 technologies.

Emergence a new stakeholder: the aggregator

Role in the smart metering deployment:

They constitute a new job for the electric market. As new actors, it is imperative to make some important investments in the R&D of the new ICT (Information and Communications Technologies). Their role is to help the consumer to control his electric energy. They are essential for the grid flexibility.

According to the CRE⁶⁶, its business model is in two parts:

- one for the capacity payment (€/MW), when a costumer made power available
- another one for the energy payment (€/MWh), when energy is delivered to the consumer.

On the following diagram there is a description of the business model of the aggregator:

⁶⁴ : 28 Avril 2011, Communiqué de Presse d’Atos : *Atos Origin démontre des offres innovantes de Maîtrise de l’Energie pour enrichir les compteurs intelligents Linky d’ERDF*,
http://fr.atos.net/fr-fr/actualites/communiques_presse/2011/2011_04_28_05.htm

⁶⁵ : Octobre 2010, Communiqué de Presse de Sagemcom, *ERDF sélectionne Sagemcom pour son expérimentation Linky CPL G3*
http://www.sagemcom.com/fileadmin/_temp_/SAGEMCOM_E_T_ENER_ERDF-LINKYPLC-G3_FR_DEF.pdf

⁶⁶ : Smart grids CRE > Dossiers > L’intégration des EnR > L’agrégateur : un nouveau métier pour le marché électrique (page 7) [all the part refers to this article]
<http://www.smartgrids-cre.fr/index.php?rubrique=dossiers&srub=integrationenr&page=7>

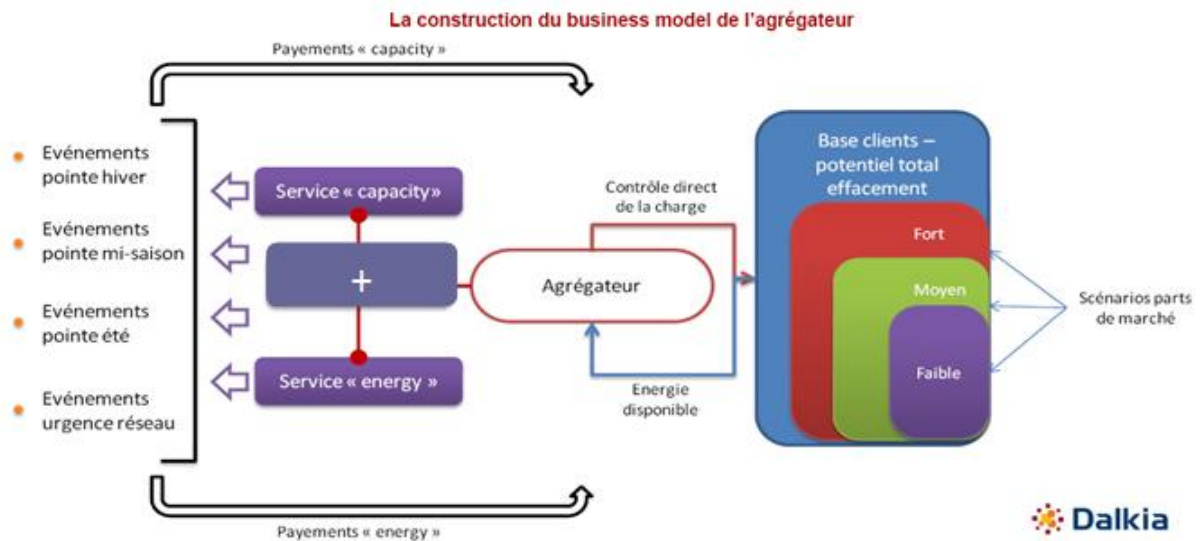

Figure A-44: Aggregator business model
Source: CRE⁶⁸ from Dalkia

The present market is in an experimental phase. Today the development for the aggregators is about the forecast. In fact, the issue is to be able to foresee the consumption of electricity as accurate as possible (one or two hours, or a few days) to determine the best demand response strategy depending on the time.

The figure below shows a summary diagram of the different stakeholders.

⁶⁸ : Smart grids CRE > Dossiers > L'intégration des EnR > page 7
<http://www.smartgrids-cre.fr/index.php?rubrique=dossiers&srub=integrationenr&page=7>

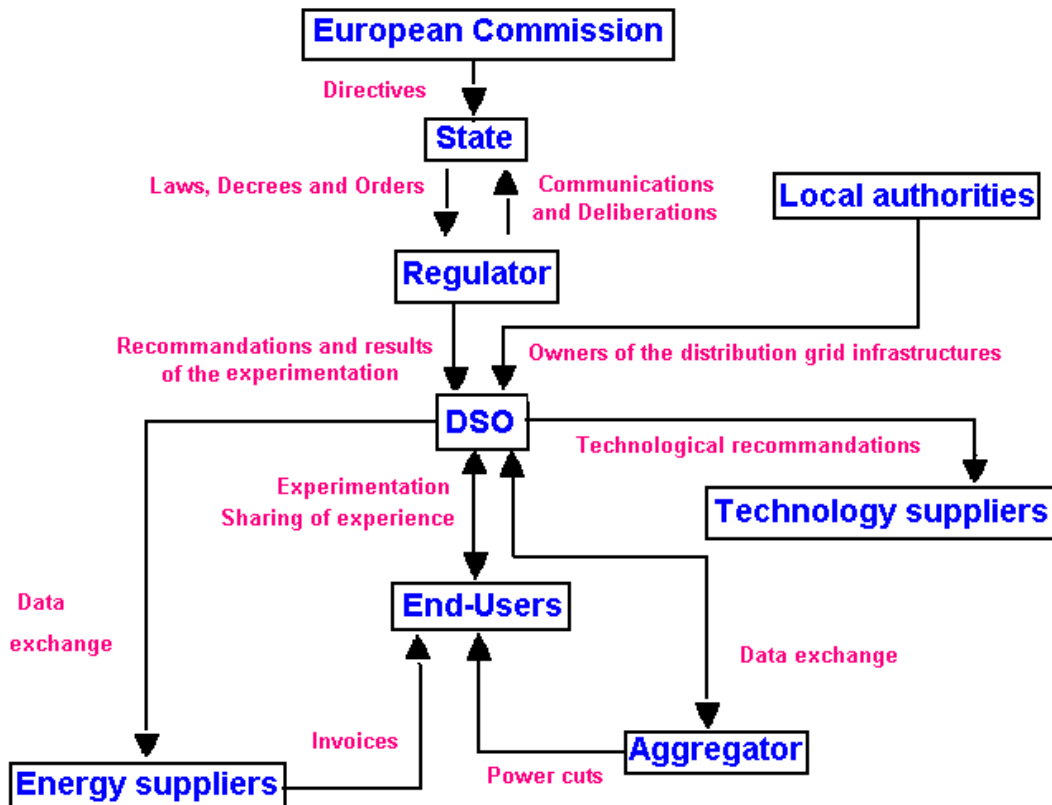

Figure A-45: Diagram of the interactions between the different stakeholders of the smart-metering

A 4.2.3 Stakeholders advantages

This part refers to the article of the CRE about the smart meters⁶⁹.

To optimize as much as possible the smart meter, it is necessary to use the different functionalities cleverly. In this way each energy market actor can take advantage of their “mission”. Some of them are described here:

- *For the producers*: it should be possible for them to wreathe the production peak and to encourage the insertion to the grid of distributed generations such as micro combined heat and power or others and renewable energies.
- *For the suppliers*: they will have the possibility to suggest various innovative offers to the end-users better corresponding to their needs. Also the suppliers will be able to read the meter on request to the DSO, so to invoice the real data to their customers.
- *For the DSO and the TSO*: it will be possible for them to read the meter reliably. It is also a chance for DSOs to realize productivity savings (fewer displacements needed), to control the non-technical losses, and to better integrate renewable energies and distributed generation to the distribution grids. Also the TSO will have the capacity to

⁶⁹ : Smart grids CRE > Dossiers > Les compteurs évolués > Quels sont les avantages pour les parties prenantes ? (page 4)

<http://www.smartgrids-cre.fr/index.php?rubrique=dossiers&srub=compteurs&page=4>

control the grid stress thanks to the EV insertion (in case it is used as a storage device for example).

- *For the consumers*: they should have a better control of their energy demand and their invoicing should be based on real data. Also they will have less trouble for the maintenance operations (because thanks to the smart-meter the maintenance operations should be made remotely); this includes reactivity and fast diagnosis, intervention and repairing as well. And of course, there will be more electricity supply offers and attached services and so a better choice for them.

A 4.2.4 The economic model

The evolution of the value chain is notably due to the appearance of the new ICT, but also of the new actors, of the new technologies and of the new services. In this innovative model, the end-user is at the center of the electrical system. The consumer has now a place in the elaboration of the business model; he is an essential actor of the system optimization. That is why it is important to inform the costumers about the data conservation conditions, the data sharing etc. to make them feel confident. In order to make the use of smart grids services commonplace, it is necessary to develop an easy access to the technology (maybe via smart phones, etc.). Today the economic model impedes the deployment of the smart-metering; there are still discussions about the investment modalities

The CRE asked *Capgemini Consulting*⁷⁰ to realize a techno-economical study about the *Linky* project. Parts of this study are available for consulting in the *Linky* Evaluation⁷¹. *Capgemini* estimates the gross investment to 3.8 billions € (whereas for ERDF it is higher, 4.3 billions €, because of some different hypothesis on the discount rate and the evolution of the wages, etc.). The study has been made for a period between 2011 and 2038 when the last “old meters” should be replaced.

For the experimentation the sequence of the events is the as follow: a massive deployment is forecasted from 2013 to 2018 with 90% of the smart meters installed. The other 10 % will be established between 2019 and 2028. Between 2013 and 2015, 7 million of smart meters should be installed involving the creation of 75 000 hubs (data concentrators) with a PLC-G1 technology. And between 2015 and 2018 a deployment of around 28 million of smart meters and 345 000 hubs (data concentrators) equipped with a PLC-G3 should occur.

The price of the electricity is one of the most important parameter; that is the reason why *Capgemini* imagined 2 different scenarios. The first one is for an annual increase of the electricity cost of 2.3% between 2010 and 2020 and the second is for an annual increase of 5.75% between 2010 and 2020. For both scenarios, from 2021 to 2038, the annual increase is of 1.8%.

Then the results are:

⁷⁰ : “Capgemini Consulting helps organizations transform their business, providing pertinent advice on strategy and supporting the organization in executing that strategy.”
<http://www.capgemini-consulting.com/get-to-know-us/about-us/>

⁷¹: CRE > Documents > Délibérations > Dossier sur l’expérimentation *Linky* (chapter IV)
<http://www.cre.fr/documents/deliberations/%28text%29/linky>.

	Net Present Value (NPV) 2011-2038 (in billion €)	
	Scenario 1	Scenario 2
Gross investments:	- 3.8	- 3.8
- meter (equipment and installation)	- 3.0	- 3.0
- hub (equipment and installation)	- 0.5	- 0.5
- information systems	- 0.3	- 0.3
Incomes on investments expenditures due to renewal of existing meters	+ 1.5	+ 1.5
Incomes on “network” investments expenditures	+ 0.1	+ 0.1
Incomes on operation expenditures related to losses	+ 1.2	+ 1.8
Incomes on operation expenditures related to technical maintenance	+ 1.0	+ 1.0
Incomes on operation expenditures related to data collecting	+ 0.7	+ 0.7
Other incomes on operation expenditures	+ 0.1	+0.1
Additional costs due to the operation of the advanced counting system	- 0.7	- 0.7
Total	+ 0.1	+ 0.7

Table A-17: Table of the NPV depending on the scenario (Source: CRE⁷²)

As it is shown for the first scenario, the equilibrium of the distribution activity is reached (+ 0.1 billion €) and in the second scenario the activity is positive (+0.7 billion €).

But being late in one of the phase of the project could have an important impact on the activity. For example if the average time spent installing the smart meter is 30% more important than for the experimentation, or if the number of hubs needed is in fact more important than expected (700 000 vs 420 000), then for the scenario1 the project is not economically viable. If the deployment of the technology *G3-PLC* comes in service in 2016

⁷² : CRE > Documents > Délibérations > Dossier sur l'expérimentation *Linky* (chapter IV)
<http://www.cre.fr/documents/deliberations/%28text%29/linky>.

instead of 2015, or if at the end of the massive deployment only 95% of the smart-meters are installed, then the NPV will be smaller of 0.05 billion € than expected.

A 4.2.5 Conclusion

Nowadays, the experimentation made possible the installation of around 250 000 smart meters. This development has been possible thanks to the force of the DSO ERDF, who has an important action power. Thanks to the *Linky* experimentation, the goal of 35 million smart meters installed seems to be accessible. This project is enriched by the fact that other DSOs can create their own smart-meters and so, by the fact launching the competition. If the deployment of the smart-metering could be resumed in 3 different steps – technological, economical and social – they would not be all at the same stage of development.

In fact, the technological success on the basic functionalities of the *Linky* meter has been proved and today a lot of manufactures are working on the research and development for other functionalities like Sagemcom, Atos, Landis & Gyr, Iton, Iskramenko and Schneider Electric.

The business model of the energy market will be modified and today the final future model is not known yet, but it needs to finish launching the economy of the smart-metering.

Most probably the most unpredictable step of the deployment is the behavior of the end-users. In fact, to make interesting the smart-meters project, end-users need to play their role by being involved in their electricity consumption and production. But this requires a change in the every day habits. However the results of the *Linky* experimentation are encouraging: 72% of the interviewed persons have a positive opinion on their new meter⁷³.

A 4.3 Involved stakeholders for integration of photovoltaic panels

A 4.3.1 The French situation

According to the *Syndicat des Energies Renouvelables*⁷⁴ (Renewable Energies Union), in 2010 the PV production represented 0.1% of the total French electricity production, that is to say 1TWh. The total power installed was 1 026 MW shared in 151 654 installations. As reported by the CRE⁷⁵, in 2011 an accumulation of 1 676 MW were installed. The 31st March 2012 the photovoltaic power installed represented 2 672 MW as it is shown below:

⁷³ : CRE > Documents > Délibérations > Dossier sur l'expérimentation *Linky* (page 22)
<http://www.cre.fr/documents/deliberations/%28text%29/linky>.

¹: 2011, *Etat des lieux et perspectives de développement des énergies renouvelables*, Syndicat des Energies Renouvelables
http://www.enr.fr/docs/2011150456_Etatdeslieuxetperspectivesdesenergiesrenouvelables.pdf

⁷⁵ : Smart Grids > CRE > Dossiers > L'intégration des EnR (page 2)
<http://www.smartgrids-cre.fr/index.php?rubrique=dossiers&srub=integrationenr&page=2>

		Photovoltaïque	
		Nb	MW
ILE DE FRANCE	31/03/12	9489	51.0
MANCHE MER NORD	31/03/12	20825	163.5
FST	31/03/12	21307	203.7
RHÔNE-ALPES-BOURGOGNE	31/03/12	40069	264.0
MEDITERRANEE	31/03/12	45894	678.2
SUD OUEST	31/03/12	33340	646.6
OUEST	31/03/12	49079	423.1
AUVERGNE-CENTRE-LIMOUSIN	31/03/12	18209	242.1
TOTAL FRANCE continentale	31/03/12	238312	2672
P moyen (MW)		0.011	

Table A-18: French Photovoltaic Installations (Source: ERDF ⁷⁶)

The 2020 goal is to have 5400 MW of photovoltaic panel established. So the 31st March 2012 there were about the half of the 2020 objective.

The PV sector has known a very fast development in only few years. The Grenelle objectives for 2011, were to have 1 100 MW installed. This aim was not only reached but exceeded. So this evolution leads to a change in the grants-in-aid, financial aids and in the feed-in tariffs⁷⁷. Indeed, in France, if the producer wants to sell his PV electricity production, he can subscribe a contract with *EDF Agence Obligation d'Achat* (EDF Purchase Obligation Agency) or with the distribution local authority⁷⁸ and so perceive corresponding remuneration for his own production. Nowadays, even if every trimester⁷⁹ the feed-in tariffs are revised, they are always higher than the price of the electricity “normally” bought. Here are the tariffs in France available from the 1st July 2012, for a residential place and for a basic option:

⁷⁶ : Avril 2012, *Installations de production raccordée au réseau géré par ERDF à fin mars 2012*
http://www.photovoltaique.info/IMG/pdf/parc_prod_mars_2012.pdf

⁷⁷ : Every PV installation connected to the grid is subjected to feed-in tariffs.

⁷⁸ : <http://www.edf-oasolaire.fr/login.action>

⁷⁹ : the feed-in tariffs are calculated every trimester by the CRE and after they are approved by an order and published in the *Journal Officiel*

<i>Power (kVA)</i>	<i>Price per kWh (€)</i>
3	0.1199
6	0.1206
9 to 36	0.1229

Table A-19: Electricity prices for the basic option of the Blue Tariff of EDF (Source: EDF Bleu Ciel⁸⁰)

From the 1st April 2012 to the 30th June 2012, the lower feed-in tariff was of 0.2035/ kWh⁸¹ (for a residential producer), about twice the price of the electricity consumed.

A 4.3.2 The stakeholders and their roles

This part is a part of the ADEME report for the call of expression of interest for the photovoltaic electricity⁸².

The deployment of the photovoltaic panels is a real challenge but also a real necessity. This technology is used for two primordial reasons: the reduction of CO₂ emissions and the selling out of the energy primary resources. As a “non-polluting” way of producing electricity and having an unlimited resource (the sun energy), photovoltaic panels seem to be a good solution. A considerable development of this technology involves a lot of stakeholders from different backgrounds.

A 4.3.2.1 Institutions

The European Commission

“The European Commission is one of the main institutions of the European Union. It represents and upholds the interests of the EU as a whole. It drafts proposals for new European laws. It manages the day-to-day business of implementing EU policies and spending EU funds.”⁸³

Role in the PV deployment:

The deployment of the photovoltaic panels has been launched in the context of the energy market liberalization. In fact the decree 96/92/CE of the 19th December 1996⁸⁴ concerning

⁸⁰ : <http://particuliers.edf.com/abonnement-et-contrat/les-prix/les-prix-de-l-electricite/tarif-bleu-47798.html>

⁸¹ : MEDDTL (Ecology, Sustainable Development, and Energy Ministry) website – Energies et Climat > Energies > Energies renouvelables > Energie solaire > Energie photovoltaïque > Tarifs d’achat

⁸² : Juin 2010, *feuille de route « Electricité photovoltaïque »*, ADEME
<http://www2.ademe.fr/servlet/getBin?name=F73FFA11BF55FC7C4E969F1A234934831294236134747.pdf>

⁸³ : Europa.eu > Home > Institutions and Bodies > European Commission
http://europa.eu/about-eu/institutions-bodies/european-commission/index_en.htm

⁸⁴ :19th December 2006,*Directive 96/92/CE concerning common rules for the internal energy market*
<http://eur-lex.europa.eu/LexUriServ/LexUriServ.do?uri=CELEX:31996L0092:FR:HTML>

common rules for the internal energy market helps the different governments to launch the renewable markets. The member states have to organize their electricity market separating the accounting and the juridical side of the production, transport and distribution in order to liberalize the supply energy market. Then after the Kyoto Protocol the European Commission wrote the Directive 2001/77/CE of the 27th September 2001⁸⁵. This Directive makes it compulsory for the State members to reach the objective of 22.1% of renewable energies in their electrical mix for 2010.

The French Government

The first step for the French Government is to transpose the European Directives in French law. For the deployment of renewable energies in general, and photovoltaic energy more particularly, the French Government wrote laws, decrees and orders, according the European Directives.

Role in the PV deployment:

The law n°2000-108 of 10th February 2000⁸⁶ concerning the modernization and the development of the public service of electricity introduced the purchase obligations for the renewable energy production.

The decree n° 2000- 877 of the 7th September 2000⁸⁷ concerning the exploitation authorization for the electricity production, stipulates that an installation of electricity production where the production is higher than 4.5 MW is subjected to an authorization demand. And when the power is under 4.5MW to exploit the installation it is necessary to declare it.

The decree n°2000-1196 of the 6th December 2000⁸⁸, specifies that over a power of 12 MW, an installation can not benefit from the purchase obligation.

The decree n°2001- 410 of the 10th May 2001 concerning the purchase conditions of the electricity produced by producers enjoying purchase obligation, stipulates that for a power installation exceeding 250 kW peak a certificate is necessary to receive the purchase obligations. In order to have the certificate it is mandatory to make a request to the prefect (government official representing the French state).

The orientations and the national energetic strategy concerning the demand side management, the renewable energies, the equilibrium and the quality of the transmission and distribution grids are described in the law n°2005-781⁸⁹ (POPE Law).

⁸⁵ : 27 September 2001, *Directive 2001/77/CE on the promotion of electricity produced from renewable energy sources in the internal electricity market*

<http://eur-lex.europa.eu/LexUriServ/LexUriServ.do?uri=OJ:L:2001:283:0033:0040:EN:PDF>

⁸⁶ : 10 Février 2000, *Loi n° 200-108 relative à la modernisation et au développement du service public de l'électricité*

<http://www.legifrance.gouv.fr/affichTexte.do?cidTexte=JORFTEXT000000750321>

⁸⁷ : 7 Septembre 2000, *Décret n°2000-877 relatif à l'autorisation d'exploiter les installations de production d'électricité*

<http://www.legifrance.gouv.fr/affichTexte.do?cidTexte=JORFTEXT000000766872>

⁸⁸ : 6 Décembre 2000, *Décret n°2000-196 fixant par catégorie d'installations les limites de puissance des installations pouvant bénéficier de l'obligation d'achat d'électricité*

<http://www.legifrance.gouv.fr/affichTexte.do?cidTexte=JORFTEXT000000586723>

The Government, in association with the CRE established a use tariff of the public electric grid (TURPE) for the producers and consumers connected to the grid⁹⁰. The calculation of this charge is based on complex operations described in the *Journal Officiel* of the 19th June 2009. It depends on the power connected to the grid and of the level voltage of the connection (low or high voltage)⁹¹. The producer has to pay this royalty to the DSO once a year.⁹²

The article n°200 quarter of the tax general code⁹³ permitted in 2010 to have a deduction of 50% of the taxes. But since 2012 the deduction decreased to reach 32%⁹⁴. Between 2010 and 2012 a lot of decrees and orders have been published modifying or completing other decrees or orders⁹⁵. These rules and regulations are available for consultation on the website *photovoltaïque.info* (which has been created by the association *Hespul* with the financial aid of the ADEME⁹⁶). This website presents all the rules and regulations in effect for the photovoltaic panels' installations⁹⁷.

In 2012 the French Government wrote the decree n°2012-38⁹⁸ fixing indemnities if the deadline for posting the connection convention, or the connection works for the installations of electricity production with renewable energies (with a power lower or equal to 3KVA) is past.

The Order of the 28th December 2011⁹⁹ approves the feed-in tariffs for 2011.

The article 16 of the law n° 2012-354 of the 14th March 2012 modifying the article 283 of the Tax General Code, stipulates that the VAT on the photovoltaic purchases is now directly given to the State by the buyer.

⁸⁹ : 13 Juillet 2005, *loi n°2005-781 de programme fixant les orientations de la politique énergétique*
<http://www.legifrance.gouv.fr/affichTexte.do?cidTexte=JORFTEXT000000813253>

⁹⁰ : http://www.photovoltaïque.info/IMG/pdf/tarif_d_utilisation_des_re_seaux_3_v020811_hespul.pdf

⁹¹ : 19 Juin 2009, *Journal Officiel de la République française*
http://www.legifrance.gouv.fr/jopdf/common/jo_pdf.jsp?numJO=0&dateJO=20090619&numTexte=17&pageDebut=09981&pageFin=09992

⁹² : There is more information about the TURPE in the paragraph of the next stakeholder (the regulator)

⁹³ : *Article 200 quarter du Code général des impôts*
<http://www.legifrance.gouv.fr/affichCodeArticle.do?idArticle=LEGIARTI000023378407&cidTexte=LEGITEXT000006069577>

⁹⁴ : *Article 200 quarter du Code général des impôts*
<http://www.legifrance.gouv.fr/affichCodeArticle.do?idArticle=LEGIARTI000023378407&cidTexte=LEGITEXT000006069577>

⁹⁵ : Photovoltaïque.info > Contexte français > Cadre réglementaire > Liste des textes réglementaires
<http://www.photovoltaïque.info/Liste-des-textes-reglementaires.html>

⁹⁶ : Photovoltaïque.info > Accueil
<http://www.photovoltaïque.info/>

⁹⁷ : Photovoltaïque.info > Contexte français > Cadre réglementaire > Liste des textes réglementaires
<http://www.photovoltaïque.info/Liste-des-textes-reglementaires.html>

⁹⁸ : 10 Janvier 2012, *Décret n°2012-38 fixant le barème des indemnités dues en cas de dépassement des délais d'envoi de la convention de raccordement ou de la réalisation du raccordement des installations de production d'électricité à partir de sources d'énergie renouvelable d'une puissance inférieure ou égale à trois kilovoltampères,*
<http://www.legifrance.gouv.fr/affichTexte.do?cidTexte=JORFTEXT000025135509&dateTexte=&categorieLien=id>

⁹⁹ : 28 Décembre 2011, *Arrêté homologuant les coefficients SN et VN*
<http://www.legifrance.gouv.fr/affichTexte.do?cidTexte=JORFTEXT000025163069>

So, for the deployment of the photovoltaic installations the Government (and some regions or local authorities) gave a lot of grants-in-aids, of reduction of taxes etc... in order to reduce the initial gross investment and so make more accessible the installation for the “lambda producer”. These dispositions had (and still continue to have) an important impact in the deployment of the photovoltaic field.

The Regulator

Role in the PV deployment:

In France the CRE is responsible of the feed-in tariffs for the photovoltaic installations. Since July 2011 every quarter the feed-in tariffs are reviewed by the CRE¹⁰⁰. This obligation has been put in place by the Government to control the number of new installations. For example if the number of connection requests is higher (respectively lower) than expected to reach the goal of 5.4 GW of installed photovoltaic panels in 2020, then the feed-in tariffs will decrease (respectively increase). This mechanism is a little more detailed later in the section 2.3.2.

Also the CRE is in charge of the adjustment of the TURPE¹⁰¹ (tariff for the use of the public electricity grid). According to the CRE¹⁰², the price considers different elements:

- the annual management component(s)
- the annual metering component(s)
- the annual injection component
- the annual decanting component
- the monthly components of the exceeding power subscribed
- the annual component of the supplementary and reserve supply
- the conventional grouping of the connection point component
- the annual component of the punctual excess programmed
- the annual component of reactive energy.

This tariff allows the exploitation and the maintenance by the grid operators of the electrical grids. It permits to cover the expenses of the investment and exploitation and maintenance made every day by the DSOs and the TSO. Every year this tariff is revised by the CRE the 1st August and put in application accordingly to the Government.

In short, the TURPE is calculated by the regulator, approved by the Government, paid by the end-users and used by the grid operators.

In addition, the CRE is in charge of the CSPE¹⁰³ (taxes for the public service of electricity). These taxes consider different charges: the tariff balancing out in the island zones, social aids for the customers in precariousness situation and also the support for the renewable energies and the combined heat and power. The law imposes to the historical energy suppliers to exercise the public service missions which are compensated by the CSPE paid by all the electricity users. The forecasts for 2012 reveal that the part for the financing of renewable

¹⁰⁰ : see the 2.3.2 for more information

¹⁰¹ : CRE > Réseaux > Réseaux publics d'électricité > Tarifs d'accès et prestations annexes <http://www.cre.fr/reseaux/reseaux-publics-d-electricite/tarifs-d-acces-et-prestations-annexes>

¹⁰² : Août 2011, *Règles tarifaires pour l'utilisation des réseaux publics d'électricité*, CRE

¹⁰³ : CRE > Dossier > CSPE http://www.cre.fr/dossiers/la-cspe#section1_1

energies in the CSPE is more than 52%¹⁰⁴. The financial aid for the photovoltaic represents 32.3% of the CSPE, the most important part of the share as it is shown on the figure below.

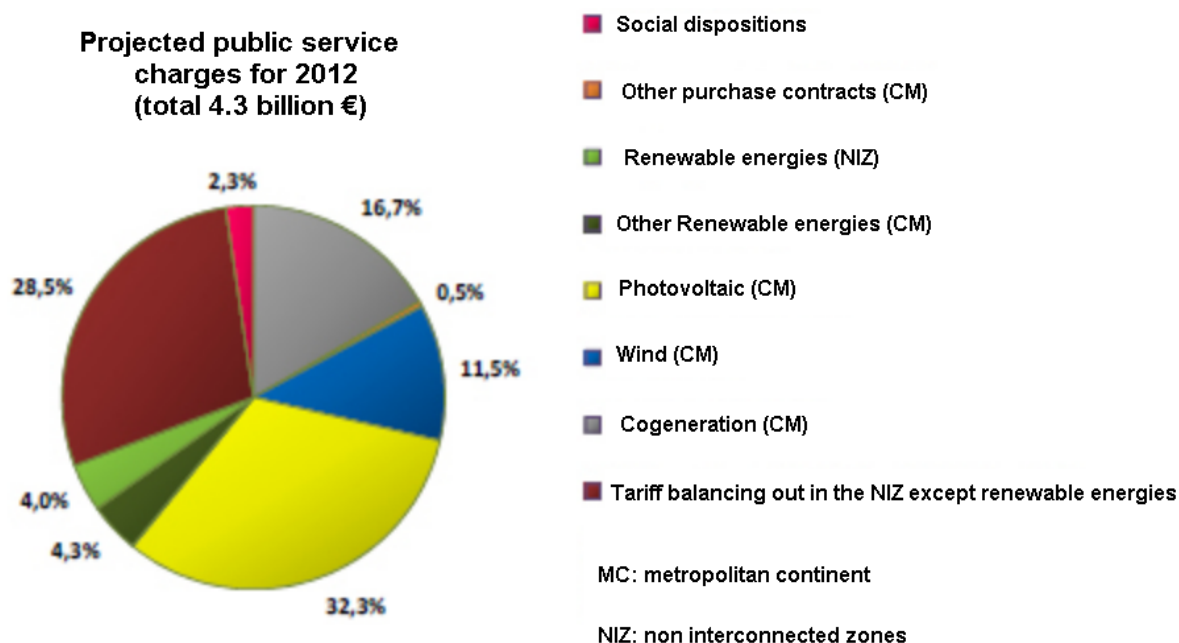

Figure A- 46: Forecasts for the 2012 CSPE repartition
Source: CRE¹⁰⁵

This tax is used by EDF *Agence Obligation d'Achats* to pay the feed-in tariffs to the producers.

A 4.3.2.2 Industrial stakeholders

DSO

Role in the PV deployment:

To connect the PV installation to the grid, it is necessary to make a request to the DSO and to have a contract with him. The owner of the installation will pay for the connection to the grid¹⁰⁶, and the DSO is responsible of the reinforcement of the grid if it is necessary. There are different stages for the connection to the grid¹⁰⁷. First the producer has to send a request to

¹⁰⁴ : CRE > Opérateurs > Service public de l'électricité (CSPE) > Montant
http://www.cre.fr/operateurs/service-public-de-l-electricite-cspe/montant#section3_1

¹⁰⁵ : CRE > Opérateurs > Service public de l'électricité (CSPE) > Montant
http://www.cre.fr/operateurs/service-public-de-l-electricite-cspe/montant#section3_1

¹⁰⁶ : Loi n° 2010-1488 du 7 décembre 2010 portant nouvelle organisation du marché de l'électricité (1) (NOME Law), article 11
<http://www.legifrance.gouv.fr/affichTexte.do?cidTexte=JORFTEXT000023174854&categorieLien=id#JORFARTI000023174892>

¹⁰⁷ : ERDF > Producteurs > Raccordement
http://www.erdfdistribution.fr/Producteurs_Raccordement

the DSO when he gets the urbanism authorization and the detailed scheme of his installation he suggests a technical and financial proposition for the connection of a PV installation. At that stage the producer has 3 months to accept the proposition or not. Then comes the connection agreement, where the exact price and the deadline for the works are defined. The customer has 3 months again to accept the proposition. Next there is the exploitation agreement, which stipulates the rules for the exploitation, among others. From this moment it is possible to begin the connection works and of course, at the end, to put in operation the photovoltaic installation.

The DSO has also to charge for the use of the network, via the TURPE. As it is written on the regulator paragraph, thanks to this tariff it is possible for the DSO to maintain and exploit the distribution grid.

Technology manufacturers

Role in the PV deployment:

- Photovoltaic panels' manufacturers:

There are two different kinds of technology: the crystalline silicon and the thin film. In France, the most famous is PHOTOWATT who is presently part of EDF. The role of a photovoltaic panel manufacturer is to put the different components of a panel together. Also, to better integrate the photovoltaic panels in buildings some firms as FONROCHE, decided to develop solutions to help this integration.

- Electronic suppliers

In order to convert the direct current into alternative current and to respect the good voltage level, electronic inverters are needed. The challenge today for the electronic suppliers is to make materials which life expectancy is higher than today. In fact, the span life of an inverter is around 10 years. But the span life of a photovoltaic panel is estimated to 20 years, so for one installation 2 inverters are needed. Today the solution they have found is to sell an inverter with its replacement during all the span life of the photovoltaic installation.

Integrated systems constructors

Role in the PV deployment:

It is a new work of the photovoltaic chain. They will develop directly the incorporation of photovoltaic panels into buildings (in the roof but also in a façade). For this, they need to reinforce the relation between architects and engineers and between the different bodies of installation job.

Installers

Role in the PV deployment:

They are responsible of the technical installation of photovoltaic panels. Today most of them do not have a specific training for this kind of installations and so it is difficult for them to give the best technical solution. So electricians and roofer have to learn new methods of working, and maybe new techniques in order to better integrate the photovoltaic modules to the roof. It is important that they work together to be able to suggest the better technical proposition to the future producers.

Installation owners and producers

Role in the PV deployment:

There are two different kinds of installation owners. It can be just someone who rent his plot

of land or his roof to an energy producer. This installation owner “just” possesses his land and does not get involved in the exploitation of the photovoltaic installation.

Others can be the owner of the place (roof or plot of land) but also the owner of the equipment for the electricity production. In this case they support all the cost of the investment in the photovoltaic panels. The producer has to contract a request to *EDF Agence Obligation d'Achat* or to the distribution local authority if he wants to sell his production (only the extra or all his production). This contract will be available during 20 years. If he wants to consume and store by himself the electricity produced thanks to the photovoltaic panels he does not have to subscribe a contract. But whatever the kind of installation (self consumption or not) the producer has to connect his photovoltaic system to the grid and to choose his selling option: all the production, only the extra or self-consumption.¹⁰⁸

¹⁰⁸ : [Photovoltaique.info](http://www.photovoltaique.info) > Accueil > Réaliser un projet > Particuliers > Raccordement
<http://www.photovoltaique.info/Raccordement.html>

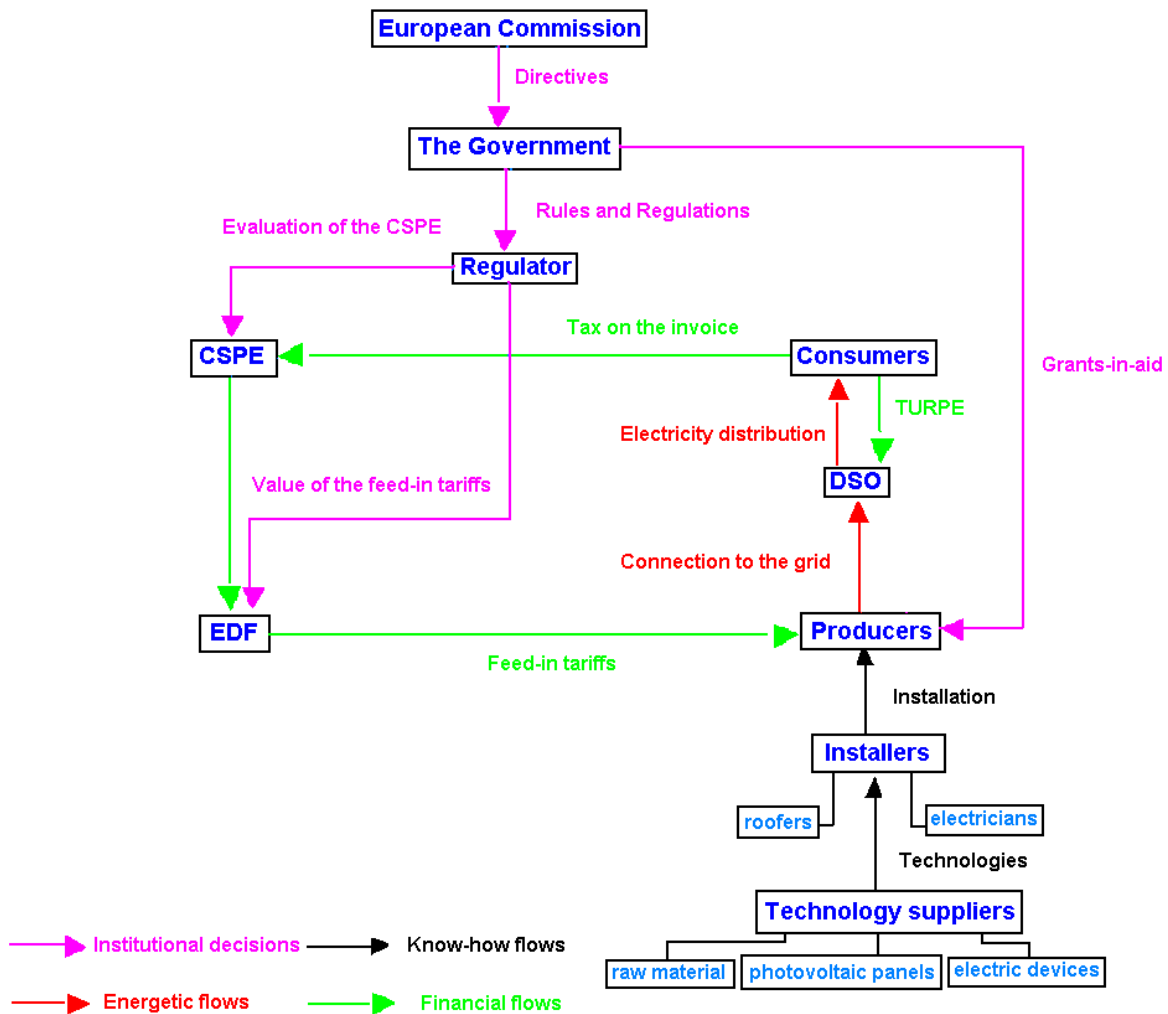

Figure A-47: Diagram of the different interactions between the different stakeholders of the PV

A 4.3.3 Technical impacts on the grid

A 4.3.3.1 Technical problems due to a massive insertion of PV

The connection to the grid can cause some technical problems on the network. In fact the massive integration of photovoltaic systems to the grid is not without any consequence: residual voltage even if the PV installation does not work, absorption or/ and production of reactive power, over-frequency phenomenon, disturbance between the inverters, etc.

According to the ESPRIT report¹⁰⁹ the most important impact is the local voltage rise. In fact if there are a lot of PV installations, and so production sources, there is an increase in the

¹⁰⁹ : Avril 2010, *Raccordement des installations photovoltaïques au réseau public de distribution d'électricité basse tension*, H. Colin (CEA-INES), C. Duvauchelle (EDF), G. Moine (TRANSENERGIE), Y. Tanguy (TRANSENERGIE), B. Gaiddon (HESPUL) et T. Tran-Quoc (IDEA)
http://www.photovoltaique.info/IMG/pdf/esprit_de_tection_i_lotage_de_cembre_2011.pdf

voltage level, above all when the consumption is very low. Different solutions have been found to avoid this kind of problem:

- by limitation of the number of users or of the total injected power in order to have everywhere in the grid a voltage level lower than the maximum level admissible. It is the case in France with the GDO low voltage level method. It has been created in the 70's by EDF¹¹⁰ in order to estimate in every point of the grid the voltage.
- by changing the design of the grid to better integrate photovoltaic panels
- by allowing the connection for an important number of photovoltaic installations but only if the inverters are equipped with a function of injected power limitation when the voltage level is too high
- by allowing the connection for an important number of photovoltaic installations but only if the inverters are equipped with a function of reactive power setting and control.

Also in case of important integration of photovoltaic panels and of loss of the uphill grid some voltage bumps can appear. This is due to the imbalance between the production and the consumption. According to the ESPRIT report, the bumps can reach 200% of the maximum voltage.

Another impact of the integration of photovoltaic installation is the increase of the current harmonics. Some studies¹¹¹ show that if the inverters are of the same kind then the current harmonics are very important.

A Spanish study¹¹² proved that the inverters inject into the grid with direct current, whatever the kind of inverters (high or low frequency with transformers or without transformer). Another study called “*DC Injection into Low Voltage AC Networks*”¹¹³ of 2005 makes mention of various problems for the distribution networks in presence of direct current: the malfunctioning of the residual circuit-breakers, of energy-meters, the affection of the life expectancy of the network components, etc.

Another aspect of this massive integration of PV installations is the contribution to the short-circuit currents. In fact the massive penetration of PV, all the more at the end of the grid and with lines at important impedance, has a bad consequence on the coordination of the network protection devices.

¹¹⁰ : Arrêté u 24 Décembre 2007 *relatif aux niveaux de qualité et aux prescriptions techniques en matière de qualité des réseaux publics de distribution et de transport d'électricité*
http://www.legifrance.gouv.fr/affichTexteArticle.do;jsessionid=B729358EDA45EC7F0268B237372ACA04.tpdj_o12v_3?idArticle=LEGIARTI000021933068&cidTexte=LEGITEXT000021896659&dateTexte=20100312

¹¹¹ : Avril 2010, *Raccordement des installations photovoltaïques au réseau public de distribution d'électricité basse tension*, H. Colin (CEA-INES), C. Duvauchelle (EDF), G. Moine (TRANSENERGIE), Y. Tanguy (TRANSENERGIE), B. Gaiddon (HESPUL) et T. Tran-Quoc (IDEA) , page 19
http://www.photovoltaique.info/IMG/pdf/esprit_de_tection_i_lotage_de_cembre_2011.pdf

¹¹² : Avril 2010, *Raccordement des installations photovoltaïques au réseau public de distribution d'électricité basse tension*, , page 19
http://www.photovoltaique.info/IMG/pdf/esprit_de_tection_i_lotage_de_cembre_2011.pdf

¹¹³ : Avril 2010, *Raccordement des installations photovoltaïques au réseau public de distribution d'électricité basse tension*, page20
http://www.photovoltaique.info/IMG/pdf/esprit_de_tection_i_lotage_de_cembre_2011.pdf

The last significant consequence of the insertion of massive PV installations is their impact on the distribution network losses. A study made by the CIRED (International Center of Environment Research and Development) called “*Impact Of Distributed Generation On Losses, Draw Off Costs From Transmission Network And Investments Of The French Distribution Network Operator Erdf*” shown that the PV farms of several MW (connected to the high voltage level network) should lead to an increase of the losses whereas the residential PV installations should decrease the losses. In fact the PV farms need the construction of new works and so increase the lines’ length (involving more losses) But for the residential case the electricity produced is consumed near the installation and so the losses reduced but that depends on the consumption pattern and time of the day. According to the study (and with the hypothesis taken¹¹⁴) if the only thing considered is the distributed generation in high level voltage, the losses amplify of 887 GWh and “only” of 647 GWh when the PV connected to the low voltage level network is considered.

The high density of PV inverters has also some impacts on the grid as the imbalance between the phases. Often the PV installations are connected to a three-phase network, but with single phase inverters. If the production power is not correctly shared between the three phases of this PV system, the system will contribute to the imbalance of the network low voltage level.

All those impacts have to be treated in order to avoid the problem of islanding, that is to say the situation where a part of the network is disconnected from the main network and that “works alone” with a system of production and a system of consumption but not necessary with the good conditions (production equal to consumption). In the normal operating conditions, this operating mode is forbidden for person’s safety and proper protection of the installations¹¹⁵.

A 4.3.3.2 The solutions brought

Today, in most cases, the insertion of photovoltaic panels at LV grids does not involve specific works on the grid. The connection to the grid has to be in appropriateness to the regulations in place. The principal rules concerned¹¹⁶:

- the short-circuit currents: they do not have to harm the grid devices such as the conductors and disconnection devices
- the harmonics’ pollution
- the tariff signals : the connection to the grid should not disturb the transmission of the command orders for the tariff signals

¹¹⁴ : Avril 2010, *Raccordement des installations photovoltaïques au réseau public de distribution d’électricité basse tension*, page 23

http://www.photovoltaique.info/IMG/pdf/esprit_de_tection_i_lotage_de_cembre_2011.pdf

¹¹⁵ : Avril 2010, *Raccordement des installations photovoltaïques au réseau public de distribution d’électricité basse tension*, page 23

² : Avril 2010, *Raccordement des installations photovoltaïques au réseau public de distribution d’électricité basse tension*, page 46

http://www.photovoltaique.info/IMG/pdf/esprit_de_tection_i_lotage_de_cembre_2011.pdf

³ : 10th December 2009, Thèse : « *Architectures des réseaux de distribution du futur en présence de production décentralisée* », Marie-Cécile Alvarez-Hérault

- the fast voltage variations: they have to be compliant to the CEI 1000-2-2 norm¹¹⁷
- the voltage profile and the thermal limits: the connection to the grid of a production site should not cause the circulation of high currents and the voltage variation all over the grid should remain within 5% of the nominal voltage
- the general protection of the producer
- and the feeder of the producer.

In order to fulfil those regulations and if it is necessary ERDF, or the DSO, can issue two solutions: either the reinforcement of the distribution grid infrastructures or the creation of a dedicated feeder for the producer.

The reinforcement method consists in replacing existing conductors by conductors with a higher cross section. In this way higher currents can circulate in the grid.

But if the problems caused by the connection to the grid can not be solved with this method, the last solution is to create a dedicated feeder. This technique consists in the creation of a connection directly on the HV/MV transformer.

A 4.3.4 A frame well established

A 4.3.4.1 Technical regulations

Norms and Certifications

In France the norms are established by the AFNOR¹¹⁸. For the photovoltaic sector there are about one hundred norms and norms projects¹¹⁹. The electrical part is already submitted to the international norms (International Electro technical Commission norms and NF: French norm) and the industrials as well as the installers know them. The problem is more for the building part. In fact, according to the ADEME¹²⁰, the major problem is the interface with the building, the ten-year guarantee¹²¹, the technical advices and the regulations for the buildings welcoming public. The CSTB¹²² in coordination with the entity in charge of the regulation of the buildings welcoming public, have to find new regulations for the integration of photovoltaic panels installation into the buildings. In the following diagram there is a description of the principal norms used of the installation part (from the photovoltaic modules to the distribution grid).

¹¹⁷ : the detail of this norm is available for consultation on

http://physique-eea.ujf-grenoble.fr/intra/Formations/M2/EEATS/CSEE/PGEL53A2/Guide_conception_reseaux/08_harmoniques/Conce08c.PDF

¹¹⁸ : AFNOR is a French Association of normalisations under the authority of the Ministry in charge of the Industry

¹¹⁹ : available for consultation on

<http://www.boutique.afnor.org/normes/resultats/909e0748-26c2-4c81-9e8b-7afb8dd3f54f>

¹²⁰ : Agence De l'Énergie et de la Maîtrise de l'Énergie (French Environment and Energy Management Agency) Feuille de Route AMI ADEME photovoltaïque, May 2011 (page 54)

¹²¹ : At the end of the construction of a building the constructor is responsible during 10 years of the damages endangering the building solidity.

¹²² : independant public actor in the building department : scientific and technical center of the building (Centre Scientifique et Technique du Bâtiment)

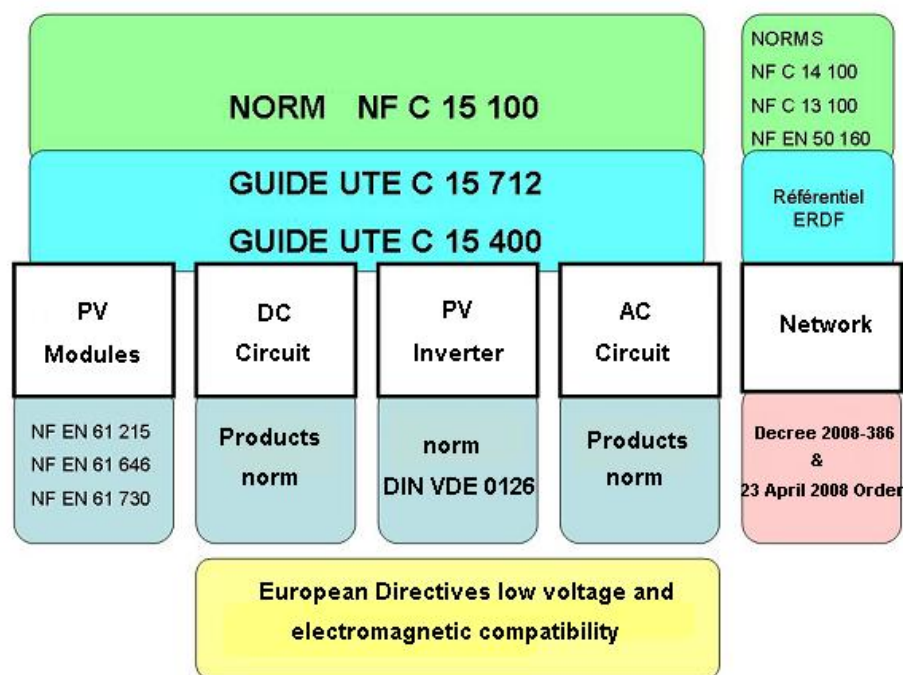

Figure A-48: Norms for the PV systems (Source: ESPRIT¹²³)

Connection to the grid

According to the Energy Code article L342-2124 when the connection is between a production installation and the distribution network the producer has to pay all the investment of the connection. By Order of the 28th August 2007, article 2125 the calculation of the connection cost depends on each DSO. The scale is established in accordance with the CRE and then published. For a connection to the low-voltage networks, the price is around €1000 for an installation where the totality of the electricity produced is injected into the grid. When just the excess of electricity is sold the connection price is between €200 and €400126. The price can change depending on the existing infrastructures, and the works it is necessary to make before the connection. Here are some tariffs for 2011 and for the installations connected to the ERDF grid.

¹²³ : Avril 2010, *Raccordement des installations photovoltaïques au réseau public de distribution d'électricité basse tension*, H. Colin (CEA-INES), C. Duvauchelle (EDF), G. Moine (TRANSENERGIE), Y. Tanguy

¹²⁴ : *Code de l'énergie > Partie Législative > Livre III : les dispositions relatives à l'électricité > Titre IV : l'accès et le raccordement aux réseaux > Chapitre II : le raccordement au réseau > Article L342-2*
http://www.legifrance.gouv.fr/affichCodeArticle.do;jsessionid=47EA5050B2C993804A50421428873521.tpdjo06v_2?cidTexte=LEGITEXT000023983208&idArticle=LEGIARTI000023986740&dateTexte=20120616&categorieLien=cid

¹²⁵ : 2007, *Arrêté du 28 Août 2007, article 2*
<http://www.legifrance.gouv.fr/affichTexte.do?cidTexte=JORFTEXT000000795938>

¹²⁶ : 2009, *Le Guide Hespul SOLAIRE PHOTOVOLTAÏQUE Démarches administratives et contractuelles pour les installations inférieures à 36 kVA*
http://www.photovoltaique.info/IMG/pdf/Le_Guide_Hespul_version_34.pdf

Ajout Production sur Consommation Existante ≤ 36 kVA - Vente en Totalité				
N° de cas	Branchement existant	Après modification	Cfb (€)	
			€ HT	€ TTC (TVA=19,6%)
Cas 9 T 1	Branchement existant souterrain ou aéro-souterrain type1, monophasée, en coffret HN 62-S-15 ou HN 62-S-20	Production monophasée, les deux compteurs sont chez le client après adaptation	739	883,84
Cas 9 T 2	Branchement existant souterrain ou aéro-souterrain type1, triphasée, en coffret HN 62-S-15 ou HN 62-S-20	Production monophasée, les deux compteurs sont chez le client après adaptation	870	1 040,52
Cas 9 T 3	Branchement existant souterrain ou aéro-souterrain type1, triphasée, en coffret HN 62-S-15 ou HN 62-S-20	Production triphasée, les deux compteurs sont chez le client après adaptation	930	1 112,28
Cas 9 T 4	Branchement existant souterrain ou aéro-souterrain type1, monophasée en coffret ou borne HN 62-S-22 ou CIBE	Production monophasée	659	788,16
Cas 9 T 5	Branchement existant souterrain ou aéro-souterrain type1, triphasée en coffret ou borne HN 62-S-22 ou CIBE	Production monophasée	736	880,26
Cas 9 T 6	Branchement existant souterrain ou aéro-souterrain type1, triphasée en coffret ou borne HN 62-S-22 ou CIBE	Production triphasée	806	963,98
Cas 9 T 7	Branchement existant souterrain ou aéro-souterrain type 2, monophasé ou triphasé en coffret ou borne HN 62-S-15, S-20, S22 ou CIBE	Production monophasée	1 408	1 683,97
Cas 9 T 8	Branchement existant souterrain ou aéro-souterrain type 2, monophasé ou triphasé en coffret ou borne HN 62-S-15, S-20, S-22 ou CIBE	Production triphasée	1 303	1 558,39
Cas 9 T 9	Branchement existant aérien monophasé, compteur chez le client	Production monophasée, compteurs chez le client	829	991,48
Cas 9 T 10	Branchement existant aérien monophasé, ensemble de comptage extérieur branchement individuel (ECEBI)	Production monophasée, compteurs chez le client	850	1 016,60
Cas 9 T 11	Branchement existant aérien triphasé	Production monophasée, les deux compteurs sont chez le client après adaptation	971	1 161,32
Cas 9 T 12	Branchement existant aérien triphasé	Production triphasée, les deux compteurs sont chez le client après adaptation	1 031	1 233,08
Cas 9 T 13	Branchement existant aérien monophasé, réseau sur toiture	Production monophasée	1 024	1 224,70
Cas 9 T 14	Branchement existant aérien triphasé, réseau sur toiture	Production triphasée	1 327	1 587,09

Table A-20: connection tariffs when all the electricity is sold (Source: ERDF¹²⁷)

¹²⁷ : 2011, Barème pour la facturation des raccordements au réseau public de distribution d'électricité concédé à ERDF, ERDF

http://www.photovoltaique.info/IMG/pdf/erdf-pro-rac_03e_bare_me_raccordement_v3.pdf

Ajout Production sur Consommation Existante ≤ 36 kVA - Vente en Surplus				
N° de cas	Branchement existant	Après modification	Cfb (€)	
			€ HT	€ TTC (TVA=19,6%)
Cas 9 S 1	Branchement existant souterrain ou aéro-souterrain type 1, monophasé, en coffret HN 62-S-20	Production monophasée, les deux compteurs sont chez le client après adaptation	511	611,16
Cas 9 S 2	Branchement existant souterrain ou aéro-souterrain type 1, monophasé, en coffret HN 62-S-15	Production monophasée, les deux compteurs sont en coffret après adaptation	336	401,86
Cas 9 S 3	Branchement existant souterrain ou aéro-souterrain type 1, triphasé, en coffret HN 62-S-15 ou S20	Production monophasée ou triphasée, les deux compteurs sont chez le client après adaptation	626	748,70
Cas 9 S 4	Branchement existant souterrain ou aéro-souterrain type1, monophasé, en coffret ou borne HN 62-S-22 ou CIBE	Production monophasée, les deux compteurs sont chez le client après adaptation	355	424,58
Cas 9 S 5	Branchement existant souterrain ou aéro-souterrain type 1, triphasé, en coffret ou borne HN 62-S-22 ou CIBE	Production monophasée ou triphasée, les deux compteurs sont chez le client après adaptation	420	502,32
Cas 9 S 6	Branchement existant souterrain ou aéro-souterrain type 2, monophasé, en coffret HN 62-S-15 ou S20	Production monophasée, les deux compteurs sont en coffrets après adaptation	408	487,97
Cas 9 S 7	Branchement existant souterrain ou aéro-souterrain type 2, triphasé, en coffret HN 62-S-15 ou S20	Production monophasée ou triphasée, les deux compteurs sont en coffrets après adaptation	528	631,49
Cas 9 S 8	Branchement existant souterrain ou aéro-souterrain type2, monophasé, en coffret ou borne HN 62-S-22 ou CIBE	Production monophasée, les deux compteurs sont en coffrets après adaptation	784	937,66
Cas 9 S 9	Branchement existant aérien monophasé	Production monophasée, les deux compteurs sont chez le client après adaptation	515	615,94
Cas 9 S 10	Branchement existant aérien monophasé, ensemble de comptage extérieur branchement individuel (ECEBI)	Production monophasée, les deux compteurs sont chez le client après adaptation	624	746,30
Cas 9 S 11	Branchement existant aérien triphasé	Production monophasée ou triphasée, les deux compteurs sont chez le client après adaptation	702	839,59
Cas 9 S 12	Branchement existant aérien réseau sur toiture	Production monophasée, les deux compteurs sont chez le client après adaptation	923	1 103,91
Cas 9 S 13	Branchement existant aérien réseau sur toiture	Production triphasée, les deux compteurs sont chez le client après adaptation	1 027	1 228,29

Table A-21: connection tariffs when only the exceeding electricity is sold
Source: ERDF¹²⁸

Urbanism code

The urbanism code needs to evolve in order to guarantee the end-user the no appearance of shadow zones in the future (such as the construction of residential blocks), and so the best productivity for the photovoltaic panels during the maximum of years. A modification of the urbanism code with a “*Right to sun*” to ensure the incomes of the photovoltaic installation may be essential.

Recycling

The way to produce electricity with photovoltaic panels is ecological but only if the installations are recycled. In fact some of the panels’ components can be used again. But nowadays, there are not a lot of centers able to recycle those components. There is only one really known on the European market: *PV Cycle*. The difficulty is that only the producers who have bought their panels from a member of *PV Cycle* can recycle for free their panels. The others can do this but under some conditions, and not for free¹²⁹.

The real problem is that today there is not any regulation concerning this point.

¹²⁸ : 2011, *Barème pour la facturation des raccordements au réseau public de distribution d’électricité concédé à ERDF*, ERDF

http://www.photovoltaique.info/IMG/pdf/erdf-pro-rac_03e_bare_me_raccordement_v3.pdf

¹²⁹: 1st December 2011, *L’avenir doublement vert des panneaux photovoltaïques passe par le recyclage*, Rachida Boughriet

<http://www.actu-environnement.com/ae/news/pv-cycle-ceres-recyclage-panneaux-solaires-PV-europe-14277.php4>

A 4.3.4.2 The feed-in tariffs

In France the production of electricity with renewable energies is entitled to purchase obligation. The article 10 of the law n° 2000-108¹³⁰ permits some installations to purchase obligation by EDF or ELDs. The installation should promote household refuse, or the use of renewable energies. According to the decree n° 2000-1196¹³¹, a renewable energy installation should not exceed 12 MW to receive the purchase obligation. If these conditions are fulfilled, then the producer has to ask for the purchase obligation to EDF *Agence Obligation d'Achat*¹³².

According to the Ecology, Sustainable Development and Energy Ministry¹³³, since July 2011, the new system makes it compulsory for the CRE to adjust the tariffs every quarter. The changes depend on the number of requests. If it is coherent with the 100MW/ year project the change will consist in a decrease of 2.6%. If there are more than that requests, then the tariff will decrease more than 2.6% (and vice-versa if there are less requests than expected). That measure has been taken in order to control the number of installations to reach the 2020 goal of 5 400 MW installed.

The article 9 of 4th March 2011 tariff decree¹³⁴ obliges the requesters of a 9 kW (or more) installation to bring an accounting or financial document to show that the costumers are able to pay such an investment. The next diagram shows the evolution of the feed-in tariffs from the 1st July 2011 to the 30 June 2012.

¹³⁰: 10th February 2000, Law n° 2000-108, article 10

<http://www.legifrance.gouv.fr/affichTexteArticle.do?cidTexte=JORFTEXT000000750321&idArticle=LEGIARTI000006628157&dateTexte=&categorieLien=cid>

¹³¹: 6th December 2000, *Decree n° 2000-108*

<http://www.legifrance.gouv.fr/affichTexte.do?cidTexte=JORFTEXT000000586723>

¹³²: 4th February 2010, *Obligation d'achat des energies renouvelables*

<http://www.developpement-durable.gouv.fr/L-obligation-d-achat-de-l.html>

¹³³: MEDDTL (Ecology, Sustainable Development, and Energy Ministry) website – Energies et Climat > Energies > Energies renouvelables > Energie solaire > Energie photovoltaïque > Tarifs d'achat

¹³⁴: Arrêté du 4 Mars 2011 fixant les conditions d'achat de l'électricité produite par les installations utilisant l'énergie radiative du soleil

<http://www.legifrance.gouv.fr/affichTexte.do?cidTexte=JORFTEXT000023661449&categorieLien=id>

Type d'installation			Tarifs en vigueur pour les installations dont la demande complète de raccordement a été envoyée :				
			avant le 1er juillet 2011	entre le 1er juillet 2011 et le 30 septembre 2011	entre le 1er octobre 2011 et le 31 décembre 2011	entre le 1er janvier 2012 et le 31 mars 2012	entre le 1er avril 2012 et le 30 juin 2012
Résidentiel	IAB ¹	[0-9kW]	46,00 c€/kWh	42,55 c€/kWh	40,63 c€/kWh	38,80 c€/kWh	37,06 c€/kWh
		[9-36kW]	40,25 c€/kWh	37,23 c€/kWh	35,55 c€/kWh	33,95 c€/kWh	32,42 c€/kWh
	ISB ²	[0-36kW]	30,35 c€/kWh	27,46 c€/kWh	24,85 c€/kWh	22,49 c€/kWh	20,35 c€/kWh
		[36-100kW]	28,83 c€/kWh	26,09 c€/kWh	23,61 c€/kWh	21,37 c€/kWh	19,34 c€/kWh
Enseignement ou santé	IAB	[0-9kW]	40,60 c€/kWh	36,74 c€/kWh	33,25 c€/kWh	30,09 c€/kWh	27,23 c€/kWh
		[9-36kW]	40,60 c€/kWh	36,74 c€/kWh	33,25 c€/kWh	30,09 c€/kWh	27,23 c€/kWh
	ISB	[0-36kW]	30,35 c€/kWh	27,46 c€/kWh	24,85 c€/kWh	22,49 c€/kWh	20,35 c€/kWh
		[36-100kW]	28,83 c€/kWh	26,09 c€/kWh	23,61 c€/kWh	21,37 c€/kWh	19,34 c€/kWh
Autres bâtiments	IAB	[0-9kW]	35,20 c€/kWh	31,85 c€/kWh	28,82 c€/kWh	26,09 c€/kWh	23,61 c€/kWh
		[0-36kW]	30,35 c€/kWh	27,46 c€/kWh	24,85 c€/kWh	22,49 c€/kWh	20,35 c€/kWh
	ISB	[36-100kW]	28,83 c€/kWh	26,09 c€/kWh	23,61 c€/kWh	21,37 c€/kWh	19,34 c€/kWh
Tout type d'installation	[0-12MW]	12,00 c€/kWh	11,68 c€/kWh	11,38 c€/kWh	11,08 c€/kWh	10,79 c€/kWh	

Table A-22: Purchase obligation price grid for the different types of installations
(Source: MEDDTL¹³⁵)

IAB and ISB are two different standards of building integration. IAB means building integration (*Intégration Au Bâti* in French), and ISB simplified building integration (*Intégration Simplifiée au Bâti* in French). To have the ISB standard it is necessary to fulfill the following conditions¹:

- the photovoltaic system is installed in the roof of a building ensuring the protection of the persons, the animals, the goods and the activities
- the photovoltaic system replace some elements of the building, protecting the roofing and protecting from the water infiltrations.

The IAB standard is more restrictive than the ISB¹.

At the signature of the contract, the feed-in tariffs are available for 20 years.

The regulator is in charge of the data aggregation recovered thanks to the DSO. Afterwards, the CRE calculates the new coefficients determining the tariff evolution¹³⁶ and publishes them in a deliberation. These values are temporary until the approval of the State with an order and the publication in the *Official Journal*.

The Government has deployed a lot of means to make the large investments easier, above all for the particular. Nevertheless some important projects exist. For example the Government launched a tender for installations from 100 kW peak to 250 kW peak (that represents between 1000m² and 2500 m²). This tender concerns most of all the medium-sized roofs. According to the press release of the Ecology, Sustainable Development, Transports and the

¹³⁵ : MEDDTL (Ecology, Sustainable Development, and Energy Ministry) website – Energies et Climat > Energies > Energies renouvelables > Energie solaire > Energie photovoltaïque > Tarifs d'achat

¹³⁶ : CRE > Documents > Délibérations > Communication du 21 Juillet 2011
<http://www.cre.fr/documents/deliberations/communication/tarifs-photovoltaique-du-1er-juillet-au-30-septembre-2011>

housing Ministry and of the Economy, Finances and Industry Ministry¹³⁷, 218 projects have been considered as acceptable by the CRE. In this way 45 MW of photovoltaic panels should be installed. In the requirements one of the important things was the guarantee of recycling the photovoltaic panels at the end of life of the installation. This tender is part of the reduction cost of the photovoltaic panels. Eric Besson, Secretary of State of the Economy, Finances and Industry at that time, said that the average price for a photovoltaic installation was around 229 €/MWh¹³⁸ in this tender as against 370 €/MWh before the new dispositions of tenders. This indicates that this is a good way to deploy the photovoltaic industry. Every quarter tenders of 30 MW are launched by the CRE. Also a tender for installations of 250 kW peak or more (large roofs or PV farms on the floor) has begun in September 2011. The requirements aim at a creation of an excellence field, or for the development of the storage solutions.

A 4.3.4.3 Large scale projects

In terms of projects the most important are the photovoltaic power plants of *Gabardan* (in the South-West of France) and of *Toul* (in the North-East of France) .

The commissioning of the Gabardan photovoltaic power plant has been made in October 2011¹³⁹ . It is a power plant on the floor. The total power capacity of the installation is of 67,2 MW peak shared in 872 300 photovoltaic panels produced by *First Solar*. This power plant produces the equivalent of the electric consumption of 37 000 inhabitants. 11 100 PV panels take part of a pilot project of 2 MW peak: there are panels fixed on trackers. In this way they can follow the sun path and so produce more. The *Aquitaine* region, the ADEME and the European funds of regional development FEDER made possible this 2 MW peak project. This power plant has been developed and built by EDF EN France. The exploitation and the maintenance are made by EDF EN Services. The total financial investment reaches 300 million euros¹⁴⁰ . This photovoltaic power plant should avoid the emission of 5 000 tons of CO₂¹⁴¹ .

¹³⁷ : 22 Mars 2012, *Désignation des 218 lauréats de la première tranche de l'appel d'offres photovoltaïque sur les toitures de taille moyenne*

<http://proxy-pubminefi.diffusion.finances.gouv.fr/pub/document/18/12495.pdf>

¹³⁸ : 22 Mars 2012, *Désignation des 218 lauréats de la première tranche de l'appel d'offres photovoltaïque sur les toitures de taille moyenne*

<http://proxy-pubminefi.diffusion.finances.gouv.fr/pub/document/18/12495.pdf>

¹³⁹ : 6 Octobre 2011, Communiqué de presse, *EDF Energies Nouvelles achève la mise en service de la centrale solaire du Gabardan en France*

http://www.edf-energies-nouvelles.com/uploads/medias/1576/cp_061011_legarbardan_fr.pdf

¹⁴⁰ : *Aquitaine region website*

<http://www.aqui.fr/environnements/la-centrale-photovoltaïque-du-gabardan-dans-les-landes-le-difficile-equilibre-entre-production-energetique-et-protection-de-l-environnement,2453.html>

¹⁴¹ : 6 Octobre 2011, Communiqué de presse, *EDF Energies Nouvelles achève la mise en service de la centrale solaire du Gabardan en France*

http://www.edf-energies-nouvelles.com/uploads/medias/1576/cp_061011_legarbardan_fr.pdf

The project of the Toul photovoltaic power plant is the rehabilitation of a military area into the biggest European photovoltaic installation on the floor¹⁴². EDF EN is in charge of this project too.

The power installation will be between 115 and 135 MW peak. It represents the electric consumption of 60 000 inhabitants. The number of photovoltaic panels will be between 1.4 and 1.7 million and will occupy 367 hectares. This is a large project: on one hand because of the massive destruction of the buildings, and on the other hand by the size of the project. The photovoltaic modules are made by *First Solar* and designed with thin film technology. The commissioning of this power plant will be effective in 2013. The ground belongs to the French state. So in April 2011, EDF EN has rented the ground of the former- military base with a long lease¹⁴³. At the end of the 30 years lease¹⁴⁴ either it is extended for the exploitation of the photovoltaic panels or EDF undertakes to dismantle and recycle the photovoltaic power plant.

A 4.3.5 ...to reach the objectives

A 4.3.5.1 Business model

Today the gross investment of a photovoltaic installation is composed of several elements¹⁴⁵:

- the feasibility study: it checks if there is no problem to install the photovoltaic panels (shade, exposition to the sun, orientation etc...), and it evaluates if there is problem for the connection to the grid.
- the equipment and the installation: the price depends on the system size and on the peak power wished. Below there is a table of the prices as a function of the peak power for 2011:

Power	Price for ISB (excluding VAT)	Price for IAB (excluding VAT)
< 3 kWp	2.9 to 3.6 €/Wp	3 to 3.8 €/Wp
3 to 36 kWp	2.7 to 3.3 €/Wp	2.8 to 3.4 €/Wp
36 to 100 kWp	2.3 to 3 €/Wp	2.4 to 3 €/Wp

Table A-23: Equipment and installation prices
(Source: Photovoltaïque.info¹⁴⁶)

¹⁴² : Novembre 2011, Dossier de Presse, *Centrale photovoltaïque BA 136 Toul-Rosières*
http://www.edf-energies-nouvelles.com/uploads/medias/1596/dp_edfen_toulrosieres_nov20011.pdf

¹⁴³ : Novembre 2011, Dossier de Presse, *Centrale photovoltaïque BA 136 Toul-Rosières*
http://www.edf-energies-nouvelles.com/uploads/medias/1596/dp_edfen_toulrosieres_nov20011.pdf

¹⁴⁴ : Novembre 2011, Dossier de Presse, *Centrale photovoltaïque BA 136 Toul-Rosières*
http://www.edf-energies-nouvelles.com/uploads/medias/1596/dp_edfen_toulrosieres_nov20011.pdf

¹⁴⁵ : Photovoltaïque.info > Contexte français > Coûts et Financement > Coûts d'investissement
<http://www.photovoltaique.info/Couts-d-investissement.html>

- works of connection to the grid: this cost includes the meters and circuit breakers, and the wiring. For a connection to a 36 kVA or less to the grid, the price is about 1.000€ for a simple configuration and around 1.500€ for a complex one.
- And the cost of the loan. The interest rate is difficult to estimate because it depends on the organism chosen and of the amount borrowed.

After the gross investment there are also the working costs. Among them one can list the maintenance, the inverter and the use tariff of the public electric grid (TURPE 3). The cost of the maintenance is difficult to know because it depends on the orientation, the place, the weather of the place, etc. Today the inverters have a life span of 8 to 10 years and the photovoltaic panels of 20 years. So they need to be changed at least once during the exploitation period.

The TURPE 3 is available from the 1st August 2009 to 2013 maximum. Every 1st August the CRE adjusts this tariff as a function of the inflation, and other parameters. Then the new tariff is published in the *Official Journal* and at this time it becomes certified¹⁴⁷. In 2011, for a photovoltaic installation of power less than 18 kVA the TURPE 3 was 51.24€ (without VAT), and for a power installation between 18 kVA and 36 kVA the tariff was 4.96€ (without VAT)¹⁴⁸.

According to the ADEME¹⁴⁹, the integration of the solar energy will need some modifications. The new business model should have developed techniques to insert massively the distributed and intermittent energies to the grid. Also developments of a new regulation evaluating the working cost of the grid, and rules about the invoicing price of these working costs for the different energy market actors (producers, suppliers and consumers) are imperative. This new business model will include the electricity storage and the demand side management with economic actors who will suggest electricity offers in a different way than today. Also a change in the technologies and in the market is expected for this new business model. The change will be in the storage of the energy and in the DSM (Demand Side Management) to have new ways of making electricity offers in the market. In order to better understand all this new organizations it is necessary to use pilot projects and to use the results to improve the different technologies.

A 4.3.5.2 Targets for 2020

In order to reach the targets requested by the Environment Grenelle for 2020¹⁵⁰ in the best conditions as possible, France needs to fulfill some points. According to the ADEME¹⁵¹, it is

¹⁴⁶ : Photovoltaïque.info > Contexte français > Coûts et Financement > Coûts d'investissement
<http://www.photovoltaïque.info/Couts-d-investissement.html>

¹⁴⁷ : CRE > Réseaux > Réseaux publics d'électricité > Tarifs d'accès et prestations annexes
<http://www.cre.fr/reseaux/reseaux-publics-d-electricite/tarifs-d-acces-et-prestations-annexes>

¹⁴⁸ : Photovoltaïque.info > Contexte français > Coûts et Financement > Coûts de fonctionnement
<http://www.photovoltaïque.info/Couts-de-fonctionnement.html>

¹⁴⁹ : Agence De l'Énergie et de la Maîtrise de l'Énergie (French Environment and Energy Management Agency)
 Feuille de Route AMI ADEME photovoltaïque, May 2011

¹⁵⁰ : the 5.4 GW of photovoltaic panels installed

necessary to reduce the cost of the connected to the grid watt in 2010 by two for 2020 by innovating in all the value-chain. Another important aim is to make emerge national manufacturers of cells and modules able to create saleable products at less than 1€ the watt connected to the grid.

It is important also, to validate the technological and market rules allowing the massive integration of renewable energies in general, and photovoltaic more particularly, to the grid. As well, it will be essential to have French industrial specialists of the building integration with robust and sustainable technologies. The last important step is to reinforce the relations between the research in laboratories and the industrialists by developing research platforms able to accelerate the technological transfer. In order to go faster in this technological transfer some projects have emerged. Among them there are:

- **The EDF Millener project**

This pilot project is scheduled to take place in Corsica, Guadeloupe and Reunion three islands (Corsica is a French territorial division and Guadeloupe and Reunion French regions). Because of the island nature of those three places the electricity production is a real challenge. In fact there is no interconnection, or very few interconnections. That is why EDF thought about the Millener project. This experimentation consists in developing and optimizing the use of renewable energies thanks to the smart grids¹⁵². This Millener project goal is to better control the electric equilibrium thanks to the smart grids. For the volunteer customers, there are two options¹⁵³: a smart meter conducing to demand response in peak periods (some devices such as the air-conditioner or hot water tank are linked to the smart meter), or the installation of solar panels with a storage system promoting the self-consumption (the costumer produces for him-self). This project encourages the decentralized generation and the renewable production via the self-consumption the storage and the participation of the end-user to the system services.

The six different industrial partners of EDF are: BPL Global, Delta Dore, Edelia, Saft, Schneider and Tenesol¹⁵⁴.

In fact these territories share the same problems: the insertion of the intermittent energy, the management of the peak situations, the limitation of the CO₂ production, the increase of the primary energy costs, and the increase of the costs due to the feed-in tariffs of the photovoltaic panels. It should be also possible to measure the impact of the storage in the grid and so to be prepared to the *Vehicle-to-Grid*.”

¹⁵¹ : Agence De l’Energie et de la Maîtrise de l’Energie (French Environment and Energy Management Agency) Feuille de Route AMI ADEME photovoltaïque, May 2011

¹⁵² : EDF Corse et Outre-mer > Actualités > Le projet « Millener » > Pourquoi Millener?
<http://sei.edf.com/actualites/le-projet-millener/pourquoi-millener-y-83904.html>

¹⁵³ : EDF Corse et Outre-mer > Actualités > Le projet « Millener » > Comment marche Millener?
<http://sei.edf.com/actualites/le-projet-millener/comment-ca-marche-y-83905.html>

¹⁵⁴ : EDF Corse et Outre-mer > Actualités > Le projet « Millener » > Pourquoi Millener?
<http://sei.edf.com/actualites/le-projet-millener/pourquoi-millener-y-83904.html>

- **The GreenLys project**

GreenLys is a project promoting the development of the future electrical system in the cities of Lyon and Grenoble with new and smart electrical installations. This project takes part of the *Grenelle de l'Environnement* objectives¹⁵⁵.

GreenLys deals with the grid to the downstream the smart meter: the deployment of tools allowing the management of the consumption and the intermittent production is an essential component of GreenLys. In all the city specific devices will be installed in order to better know the grid behaviour in real time. Also some functions will help the advanced grid operating nodes on the low voltage grid thanks to the data issued from the *Linky* smart meter. These new functions will notably be part of self healing functions.

In Grenoble, the platform integrates more intermittent production as the photovoltaic production coupled to the charging of electric vehicles. As in Lyon, the end users participating in the project will be equipped with *Linky* smart meters¹⁵⁶. The grid of Grenoble will have the particularity to welcome an important part of renewable energies producing locally: about twenty photovoltaic sites, fifteen cogeneration plants, around thirty EVs and a fast charging station.

The objective of the project is to quantify the effect of a smart grid on the electric systems by promoting a system view.

¹⁵⁵ : GreenLys > Le projet GreenLys
<http://www.greenlys.fr/projet/>

¹⁵⁶ : GreenLys > L'expérimentation > Plateforme Grenoble
<http://www.greenlys.fr/lexperimentation/plateforme-grenoble-2/>

² : GreenLys > L'expérimentation > Plateforme Lyon
<http://www.greenlys.fr/lexperimentation/plateforme-lyon/>

³ : GreenLys > L'expérimentation > Plateforme Grenoble
<http://www.greenlys.fr/lexperimentation/plateforme-grenoble-2/>

A 4.3.6 Conclusion

The 31st March 2012 France counted 238 312¹⁵⁷ installations of photovoltaic panels all over the territory. This number confirms that the Government efforts bared its fruit: French people have well accepted the integration of those panels even if the gross investment is very significant.

Today in France the deployment of the photovoltaic panels seems to be in good track in order to reach the 2020 objective of 5.4 GW of installed capacity. This development is notably made through the regulation of the feed-in tariffs according the quarterly number of connection requests. Furthermore the regulations are well established. The technologies for the building integration and the ways to install the photovoltaic panels are domesticated. Also it is necessary to integrate the photovoltaic aspect since the construction of the building. So now the real challenge is to decrease the module prices as much as possible, without compromising their quality and to validate the business model of the photovoltaic. According to the ADEME¹⁵⁸, the business model should allow the reduction of the dependence of the field on the feed-in tariffs after 2015 and promote the self-consumption.

Nowadays the major constraint for the deployment of photovoltaic panels is the business model: in fact to launch the photovoltaic market the French Government gives grant-in-aids and put in place attractive feed-in tariffs. But today the technical part is mature and so the feed-in tariffs are decreasing. The existing model has not favored the self-consumption of the electricity produced. The feed-in tariffs are only set for a period of transition between the launch and the maturity of the photovoltaic market. But today the producers largely prefer the business model of the feed in tariff instead of the self-consumption.

¹⁵⁷ : Avril 2012, *Installations de production raccordée au réseau géré par ERDF à fin mars 2012*
http://www.photovoltaique.info/IMG/pdf/parc_prod_mars_2012.pdf

¹⁵⁸ : Agence De l’Energie et de la Maîtrise de l’Energie (French Environment and Energy Management Agency)
Feuille de Route AMI ADEME photovoltaïque, May 2011

Appendix 5 Overview of the IEA Demand-Side Management Programme

IEA Demand Side Management Programme

The Demand-Side Management (DSM) Programme is one of more than 40 co-operative energy technology programmes within the framework of the International Energy Agency (IEA). The Demand-Side Management (DSM) Programme, which was initiated in 1993, deals with a variety of strategies to reduce energy demand. The following 16 member countries and the European Commission have been working to identify and promote opportunities for DSM:

Austria	Netherlands
Belgium	Norway
Canada	New Zealand
Finland	Spain
France	Sweden
India	Switzerland
Italy	United Kingdom
Republic of Korea	United States

Sponsors: RAP

Programme Vision during the period 2008 - 2012: Demand side activities should be active elements and the first choice in all energy policy decisions designed to create more reliable and more sustainable energy systems

Programme Mission: Deliver to its stakeholders, materials that are readily applicable for them in crafting and implementing policies and measures. The Programme should also deliver technology and applications that either facilitate operations of energy systems or facilitate necessary market transformations

The Programme's work is organized into two clusters:

- The load shape cluster, and
- The load level cluster.

The 'load shape' cluster will include Tasks that seek to impact the shape of the load curve over very short (minutes-hours-day) to longer (days-week-season) time periods. Work within this cluster primarily increases the reliability of systems. The 'load level' will include Tasks that seek to shift the load curve to lower demand levels or shift between loads from one energy system to another. Work within this cluster primarily targets the reduction of emissions.

A total of 24 projects or "Tasks" have been initiated since the beginning of the DSM Programme. The overall program is monitored by an Executive Committee consisting of representatives from each contracting party to the Implementing Agreement. The leadership and management of the individual Tasks are the responsibility of Operating Agents. These Tasks and their respective Operating Agents are:

Task 1 International Database on Demand-Side Management & Evaluation Guidebook on the Impact of DSM and EE for Kyoto's GHG Targets - *Completed*
Harry Vreuls, NOVEM, the Netherlands

Task 2 Communications Technologies for Demand-Side Management - *Completed*
Richard Formby, EA Technology, United Kingdom

Task 3 Cooperative Procurement of Innovative Technologies for Demand-Side Management – *Completed*

Dr. Hans Westling, Promandat AB, Sweden

Task 4 Development of Improved Methods for Integrating Demand-Side Management into Resource Planning - *Completed*

Grayson Heffner, EPRI, United States

Task 5 Techniques for Implementation of Demand-Side Management Technology in the Marketplace - *Completed*

Juan Comas, FECSA, Spain

Task 6 DSM and Energy Efficiency in Changing Electricity Business Environments – *Completed*

David Crossley, Energy Futures, Australia Pty. Ltd., Australia

Task 7 International Collaboration on Market Transformation - *Completed*

Verney Ryan, BRE, United Kingdom

Task 8 Demand-Side Bidding in a Competitive Electricity Market - *Completed*

Linda Hull, EA Technology Ltd, United Kingdom

Task 9 The Role of Municipalities in a Liberalised System - *Completed*

Martin Cahn, Energie Cites, France

Task 10 Performance Contracting - *Completed*

Dr. Hans Westling, Promandat AB, Sweden

Task 11 Time of Use Pricing and Energy Use for Demand Management Delivery- *Completed*

Richard Formby, EA Technology Ltd, United Kingdom

Task 12 Energy Standards

To be determined

Task 13 Demand Response Resources - *Completed*

Ross Malme, RETX, United States

Task 14 White Certificates – *Completed*

Antonio Capozza, CESI, Italy

Task 15 Network-Driven DSM - *Completed*

David Crossley, Energy Futures Australia Pty. Ltd, Australia

Task 16 Competitive Energy Services

Jan W. Bleyl, Graz Energy Agency, Austria

Seppo Silvonen/Pertti Koski, Motiva, Finland

Task 17 Integration of Demand Side Management, Distributed Generation, Renewable Energy Sources and Energy Storages

Seppo Kärkkäinen, Elektraflex Oy, Finland

Task 18 Demand Side Management and Climate Change - *Completed*

David Crossley, Energy Futures Australia Pty. Ltd, Australia

Task 19 Micro Demand Response and Energy Saving - *Completed*

Barry Watson, EA Technology Ltd, United Kingdom

Task 20 Branding of Energy Efficiency

Balawant Joshi, ABPS Infrastructure Private Limited, India

Task 21 Standardisation of Energy Savings Calculations
Harry Vreuls, SenterNovem, Netherlands

Task 22 Energy Efficiency Portfolio Standards
Balawant Joshi, ABPS Infrastructure Private Limited, India

Task 23 The Role of Customers in Delivering Effective Smart Grids
Linda Hull. EA Technology Ltd, United Kingdom

Task 24 Closing the loop - Behaviour change in DSM, from theory to policies and practice
Sea Rotmann, SEA, New Zealand and Ruth Mourik DuneWorks, Netherlands

For additional Information contact the DSM Executive Secretary, Anne Bengtson, Box 47096, 100 74
Stockholm, Sweden. Phone: +46 8 510 50830, Fax: +46 8 510 50830. E-mail:
anne.bengtson@telia.com

Also, visit the IEA DSM website: <http://www.ieadsm.org>

-