

The INTER project

INtégration du Transport
Électrique dans le Réseau



gaizka.alberdi@edf.fr
25-04-2012



CHANGER L'ÉNERGIE ENSEMBLE

Summary

1. **Current European context**
2. **Future challenges for the DSO**
3. **The INTER project in a nutshell**
4. **Focus on “Smart Charging” process**
5. **Final outline**



© 2011 Médiathèque EDF

Summary





1. **Current European context**
2. **Future challenges for the DSO**
3. **The INTER project in a nutshell**
4. **Focus on “Smart Charging” process**
5. **Final outline**

© 2011 Médiathèque EDF

Current context

Main factors contributing to the EV/PHEV kick-off:

- ▶ **Economical:** Energy dependence and high oil price 
- ▶ **Environmental:** Climate change 
- ▶ **Technological:** New innovative solutions, decrease in cost 



Strong commitment from **governments** and **consumers**

Current context

The EV/PHEV help in reaching European energy policy goals:

EU wide-ranging package on climate change for 2010-2020 period aims to:

- 20% cut in emissions of greenhouse gases by 2020, compared with 1990 levels
- 20% cut in overall energy consumption
- 20% increase in the share of renewable in the energy mix

- ▶ **Sustainable development:** Control EV's CO₂ emissions. Goal: Decrease the emission levels from 160 gCO₂/km to 30 gCO₂/km for 2030
- ▶ **Security of supply:** The EU is more than 80 % dependant on oil imports
- ▶ **Economic competitiveness** Economic competitiveness generate investment and create jobs within Europe, to the benefit of both consumers and producers
- ▶ **Synergies with wind energies and other renewable:** To fulfil the EU's 2020 renewable target, significant use of energy storage and demand regulation will be needed. Future concepts such as V2G and V2H
- ▶ **SmartGrid Integration**

Current context

The UE and the governments are defining the path for:

- ▶ **Standardization** (OEM/Utility standardisation initiative)



- ▶ **Taxes and sustainable business models**

- ▶ **R&D initiatives** (EU FP7, M/468,...)

- ▶ **Experimental field tests and roll-outs**

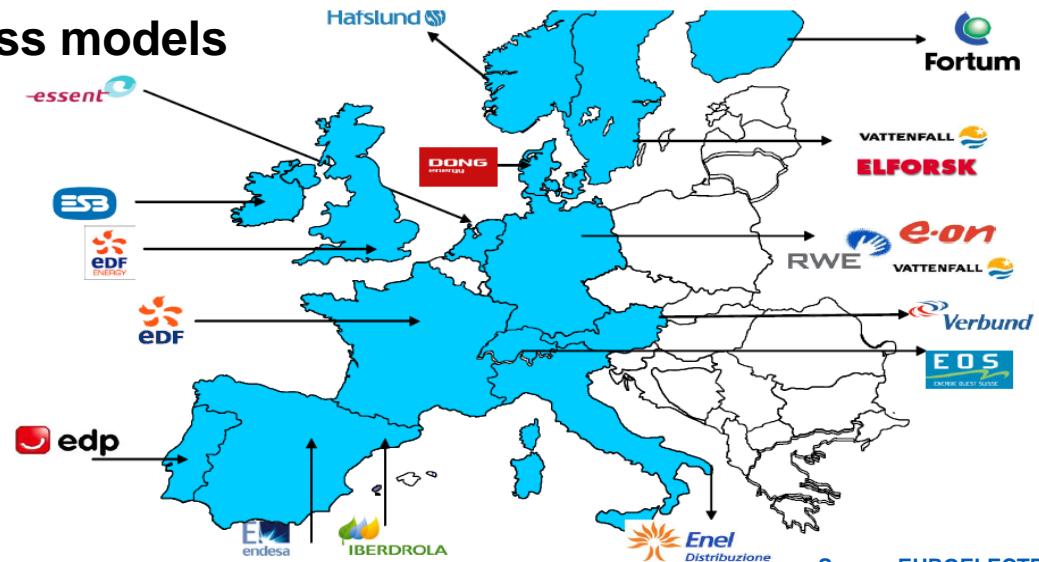

Source:EUROELECTRIC

Current context

The PHEV/EV is an important element within the SmartGrids scope

AMI + DER + DSM + PHEV/EV = Smart Grids



Summary



1. Current European context
2. Future challenges for the DSO
3. The INTER project in a nutshell
4. Focus on “Smart Charging” process
5. Final outline

© 2011 Médiathèque EDF

Forecast for EVs in France

Expected volume

- **Up to 2 million EVs** from 2020
- Equivalent to a **5% penetration** (includes vans and other light vehicles)
- Correspond to 15.000 EVs for a region of 500.000 inhabitants (study case of Rouen region)

Charging stations

- **More than 90% should be slow charging (3kVA)** at home at off-peak hours (night)
- **7-8% will be secondary slow** or accelerated charging (3, 22kVA)
- **Only 2-3% of public charging spots** will be for fast charging (43kVA)

Business-model

- In the initial phase: **simple but upgradable infrastructures for payment**
- Later and depending on business case viability: **a possible move towards e-mobility operators**
- Price for public charging paid as a service: **if paid on the cost of kWh, public subsidization policies will be needed!**

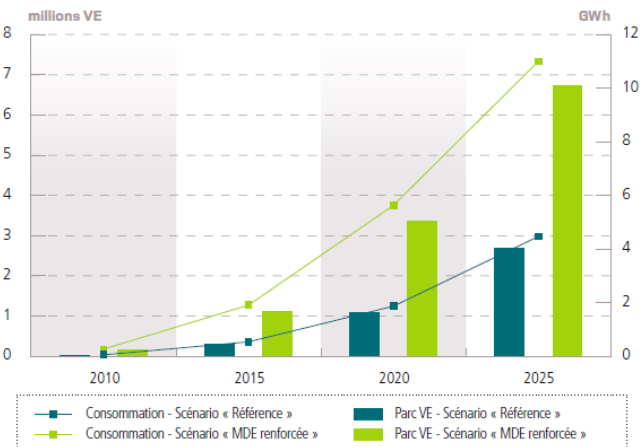

Sources:

RTE, bilan previsionnel 2009

Livre Vert sur les infrastructures de recharge ouvertes au public pour les véhicules « décarbonés », Avril 2011

A major opportunity for utilities...

- ▶ Electric vehicles represent a strong potential over the coming decade
 - Development of **CO₂-free** transportation throughout Europe
 - **Improve insertion of intermittent renewable energy sources** by offering storage and load regulation via concepts such as V2G
- ▶ With a major impact for stakeholders
 - Massive roll-out of EVs will require development of **efficient charging strategies to optimise DSO network resources**
 - **Customer understanding** and acceptance of EV charging dynamics is fundamental to success
 - **Innovative business-models** will evolve as stakeholders propose new e-mobility services and billing schemes
 - **Upcome of new billing schemes**
- ▶ To guarantee success utilities must play a key-role
 - **Involvement from the earliest design phase in order to minimize impact on the network** : to avoid congestion or dramatic increase in reinforcements, the DSO must monitor charging
 - Participation in shaping appropriate **EU policies**
 - **Develop sustainable business** models allowing simple solutions for the benefit of the customers
 - Carrying out **field tests** involving customers and in support during roll-out
 - **Standardising the charging infrastructure** and communication interfaces

... but a huge challenge to deal with

➤ DSOs are facing a challenge in handling peak load

- Slow charging of 2 million EVs simultaneously in France is equivalent of **up to a 10% increase in national peak load** but only a few % in energy consumption → current tariff structures are unadapted
- **Inefficient network reinforcement would cost billions of €** paid by end consumers → not acceptable
- Creation of EV high density zones are likely to **induce load congestion and voltage drops**

➤ Solutions should be kept simple and cost optimal

- We must define solutions based **on use cases using the existing network** adding forecasts for increase in energy consumption and load spreading
- **Fast charging must respond to foreseeable needs** and be organised and controlled to **optimise de global costs**
- **Optimising the charging locally to avoid** premature transformer ageing and control voltage variations
- **DSOs therefore must have access to local charging information and be allowed to manage overall load control on the network**

Effects of charging without optimisation

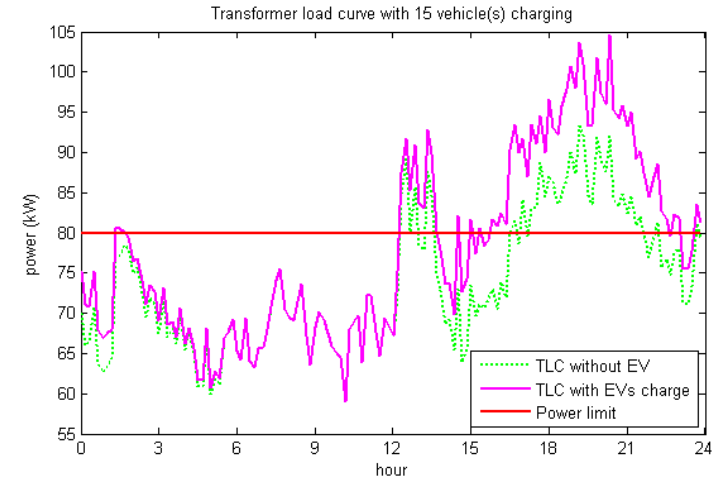

Optimised charging

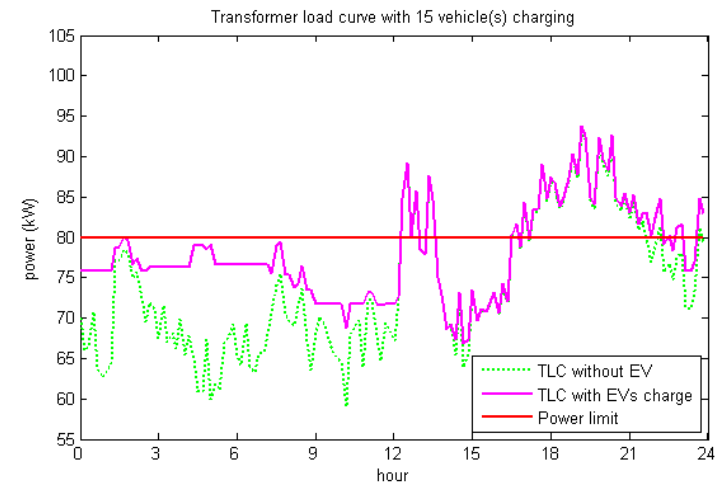

The INTER project

The INTER project was launched in 2010 to provide technical support to the French DSO, ERDF, regarding the arrival of the EV across the country.

Main objectives

- ▶ Analyze EVs impact in the distribution network
- ▶ Develop the advanced EV charging infrastructure

Future challenges for the DSO

- ▶ **Modifications within the load profile** considering future new usages
- ▶ **Impact on the network dimensioning** (extra capacity and related expenses)
- ▶ **Voltage drops**
- ▶ **Advanced Smart Metering & sub metering**
- ▶ **Laws, futures directives, mandates and standardization**
- ▶ **Integration within the SmartGrid:** advanced charging infrastructure and communication means
- ▶ **New services** for city councils and customers

Summary

1. Current European context
2. Future challenges for the DSO
3. The INTER project in a nutshell
4. Focus on “Smart Charging” process
5. Final outline



© 2011 Médiathèque EDF

General Project Overview

Scope of the project

Analyse in depths of the PHEV/EV deployment scenarios and potential grid impact

Network simulation: Overall capacity, power quality and enhancement

Smart charging infrastructure : Use cases, communication means, metering

Fleet charging infrastructure implementation and experimental field tests roll-out (GIS)

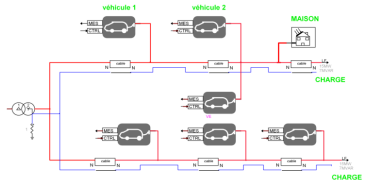
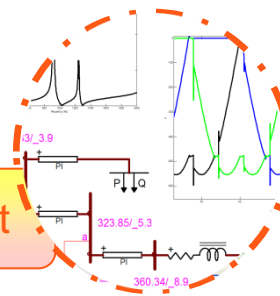
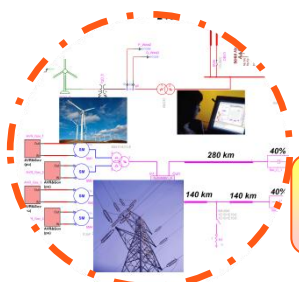
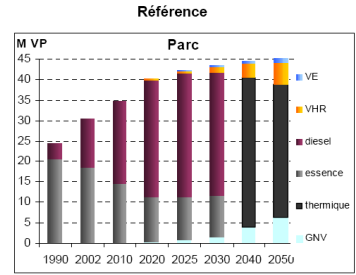
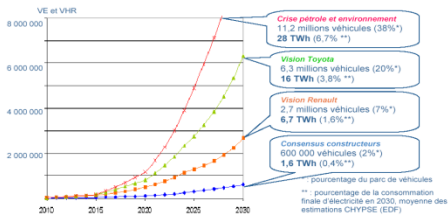

GRID IMPACT & EV-NETWORK SIMULATION

EV LOAD PROFILE

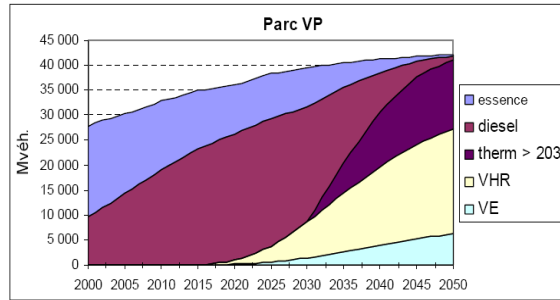
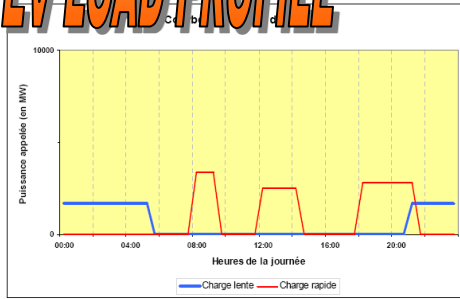

EV penetration scenarios

Simulation

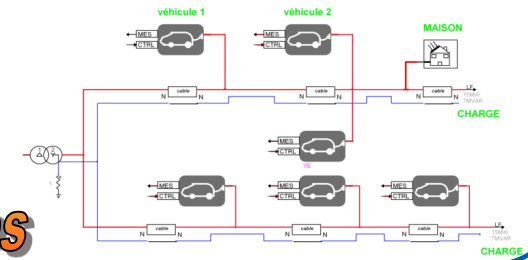

Develop a methodology capable of representing several EV/PHV load curves locally → VESAP tool (« Véhicule Electrique Simulation de l'Impact en Puissance »).

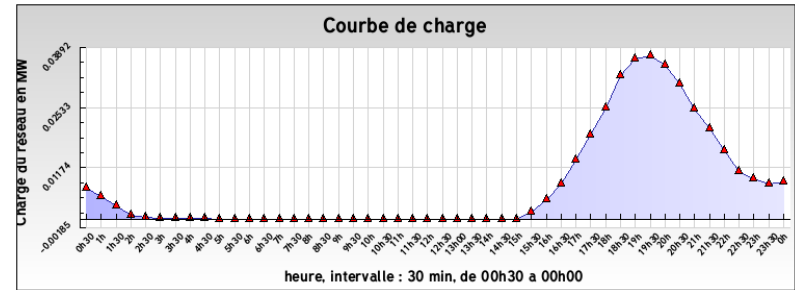

Collaboration with OEM's to model an EV charger and simulate it in a low voltage network (urban grid and parking slot).

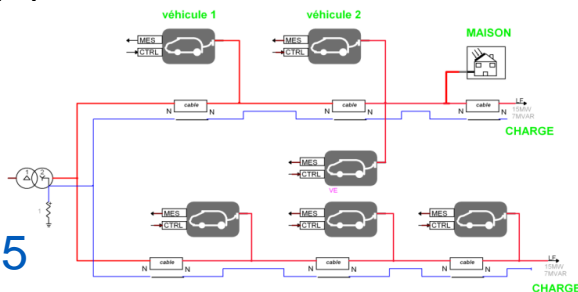

The screenshot shows the 'Proprietes pour maison1' window in the VESAP software. It displays various simulation parameters for a house with an EV charger, including power source, cost, maximum EV charging power, and selected load profiles.

Paramètre	Valeur	Unité
Puissance soustraite	0	W
coût	0,9	W
Puissance max du chargeur VE	3	W
Puissance active	4100	W
Puissance réactive	410	VAR
Puissance de charge du VE	3000	W

POWER QUALITY

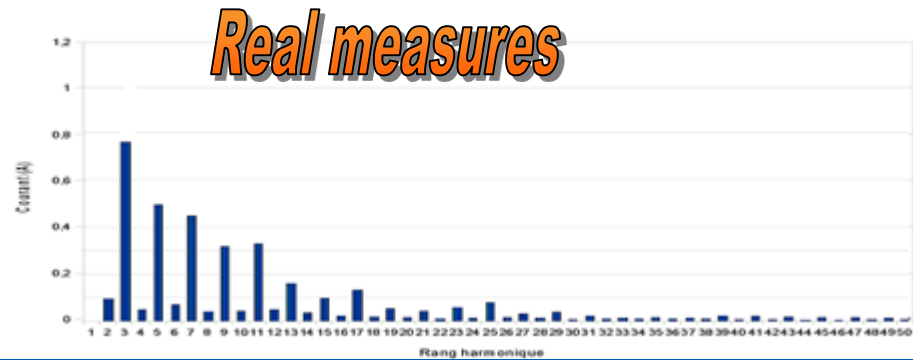
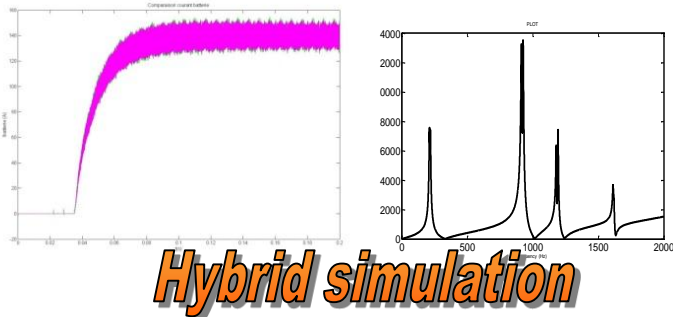

► The charging of electric vehicles is **likely to create disturbances on the network as the power increase**. Power quality disturbances like flicker, due to interruptions in the charging process for battery management, harmonics due to the AC to DC conversion, and higher frequencies disturbances (in the range 2 – 150 kHz) due to power electronic used in the charger

► **Tests fields and measurements** become necessary to understand the potential impact of EV in the grid.

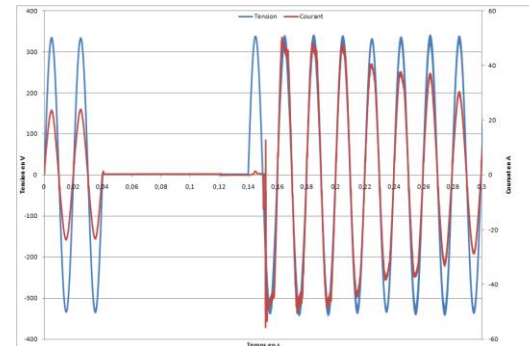
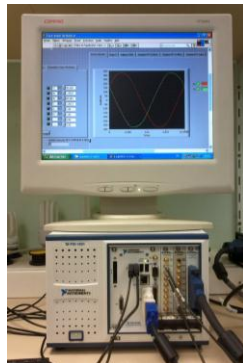

EV demonstration platform



► Research partnership launched in 2010 to develop the advanced EV charging infrastructure platform aiming to test an end to end ICT architecture to enhance EV smart charging

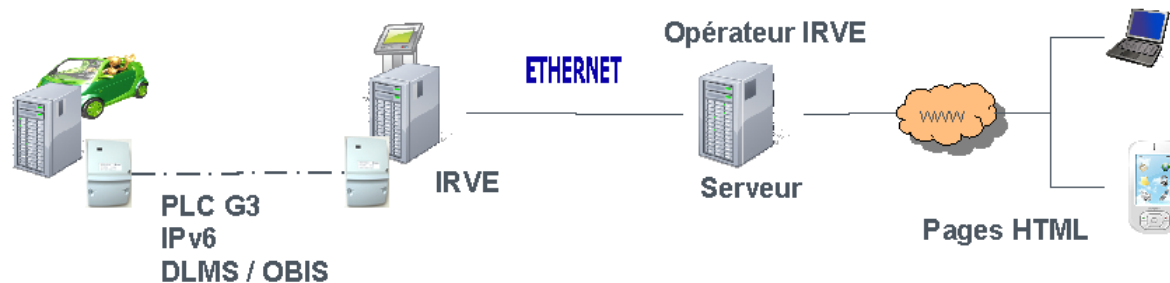

3 Bornes de charge rapide
2 Types de charge (courant de charge + connexion standard)
2 Types de charge
4 Courants de charge (travail 800V)
6 Courants de travail non actif
4 Bornes d'information
Fonction avec lecteur chargeur intégré
Pilotage électrique et hybride
Batterie à flux

28 Intégration de la batterie
2200V de recharge et de conduite
22 Courants de circulation
43 Indicateurs
44 Temps de recharge
28 Calculateur de portée batterie
28 Calculateur de consommation
28 Calculateur vitesse électrique
28 Calculateur vitesse mécanique

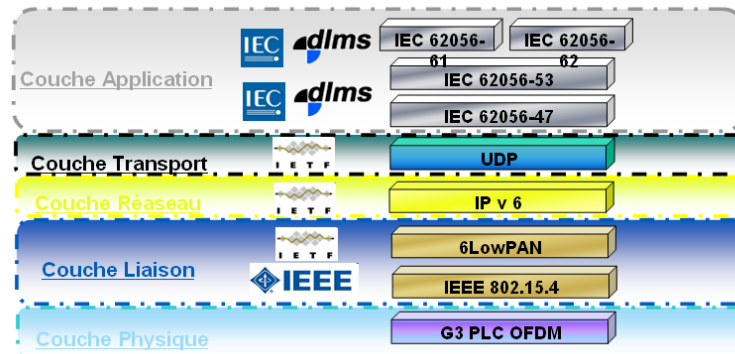

GIS-tool for spatial EV infrastructure planning

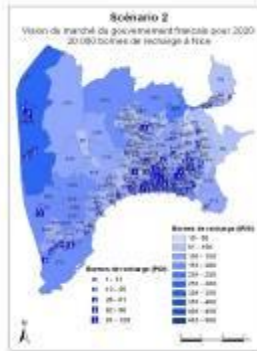

EVITA TOOL

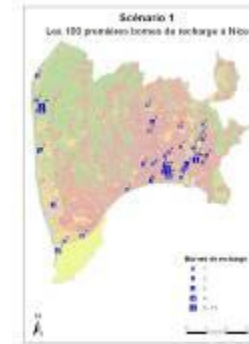

Implementation of a **planning-methodology** for **public/private charging spots**, based on geographical and social data →

EVITA - Electric Vehicle Infrastructure Tool for decision Aid

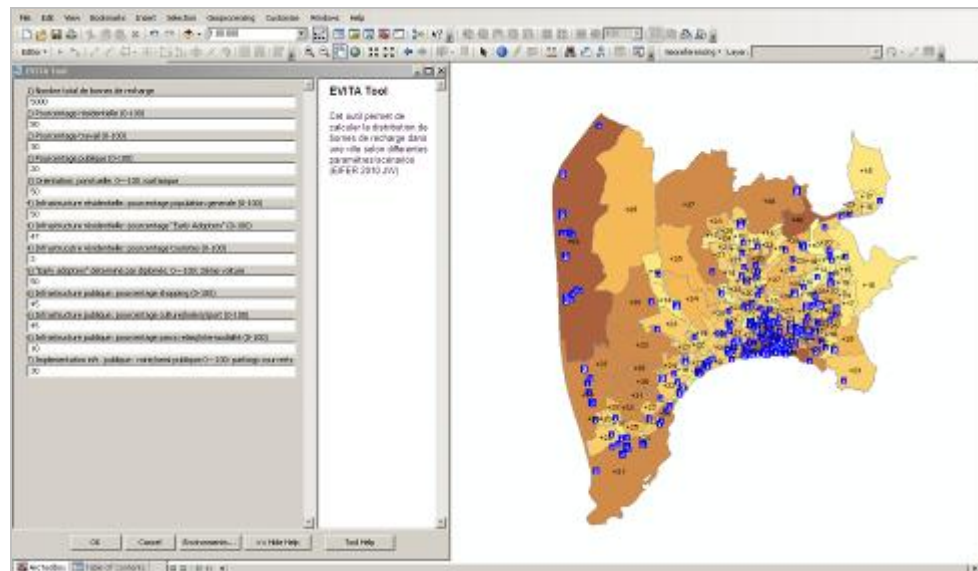

Standardization and FP 7 European projects

EV Standardization

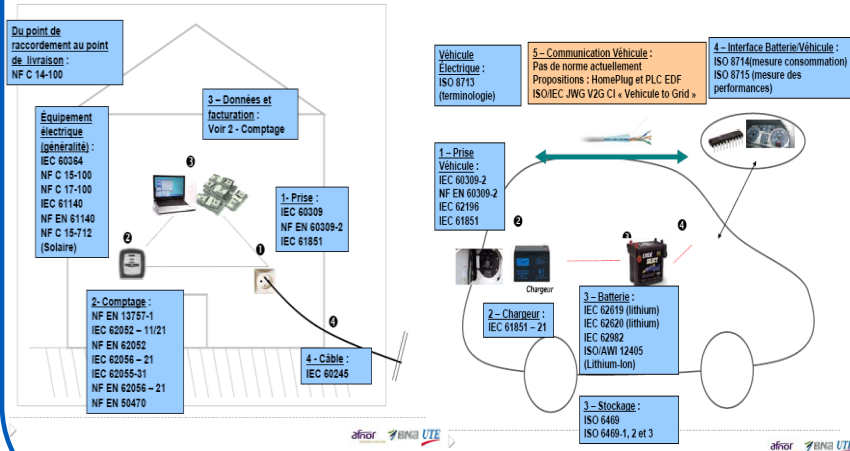

Strong involvement in:

- **IEC TC 69** to define the communication means between EV and EVSE (ISO/IEC 15118)
- Active members in **IEC TC 57** and **IEC TC 13** to guarantee EDF group vision of SmartGrids
- Permanent contribution to **M/441**, **M/468** and **M/490** through uses cases and protocol definition

G4V European Project

Graph 2: System innovation

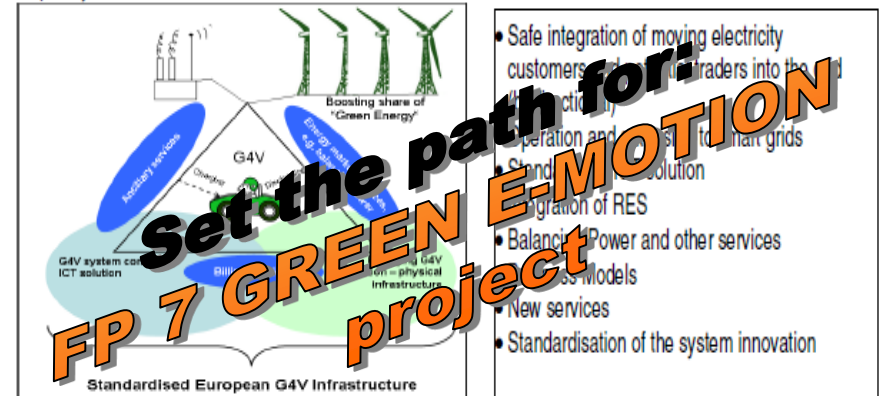

Source: Consortium

- Safe integration of moving electricity customers and traders into the grid
- Operation and control of smart grids
- Standardisation of the system innovation
- Integration of RES
- Balancing Power and other services
- Business Models
- New services
- Standardisation of the system innovation

Power Systems in Europe	 L'ENERGIA CHE TI ASSOLTA.	RES integration
Business Models		Simulation
Grid integration	 sinto a nossa energia	Consumer behaviour
Integration of RES	 	Energy Economics
	 	Demand response Energy efficiency Regulative framework

Summary

1. Current European context
2. Future challenges for the DSO
3. The INTER project in a nutshell
4. Focus on “Smart Charging” process
5. Final outline



© 2011 Médiathèque EDF

Smart Charging Use Case

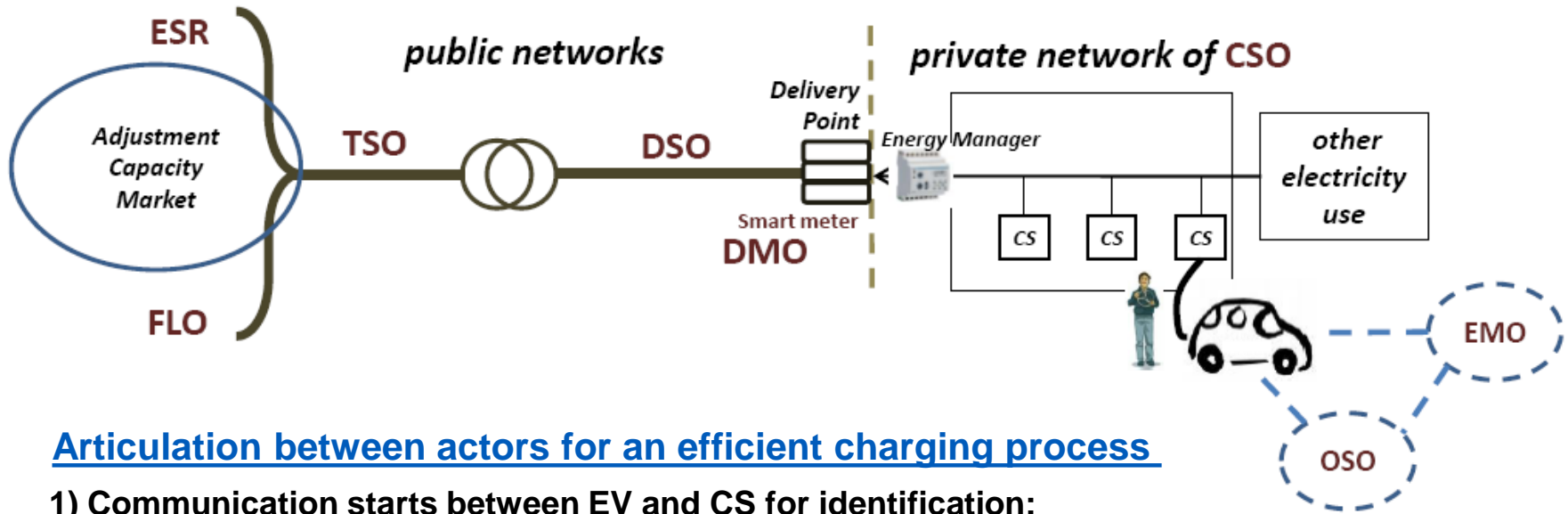

Articulation between actors for an efficient charging process

- ◆ **1) Communication starts between EV and CS for identification:**
 - Case 1: no contract, pay a charging service to the CSO (bank transaction, cash payment etc.)
 - Case 2: a contract with the CSO : use of the related ID and payment condition.
 - Case 3: a contract with an EMO : use the related ID and payment condition.
- ◆ **2) EV states its charging requirements:** an amount of electricity in a given maximum charging time.
- ◆ **3) Negotiation to settle EV's charging load profile:** under control of CSO energy manager, with exchange of data from DSO and upstream Actors, and with EMO.
- ◆ **4) Charging process:** at any time, possible re-negotiation of load profile on request of the CSO (situation change due to other consumptions, or upstream signals).
- ◆ **5) End of charging process, transaction closure:** payment billing and settlement between all Actors.

Smart Charging Use Case

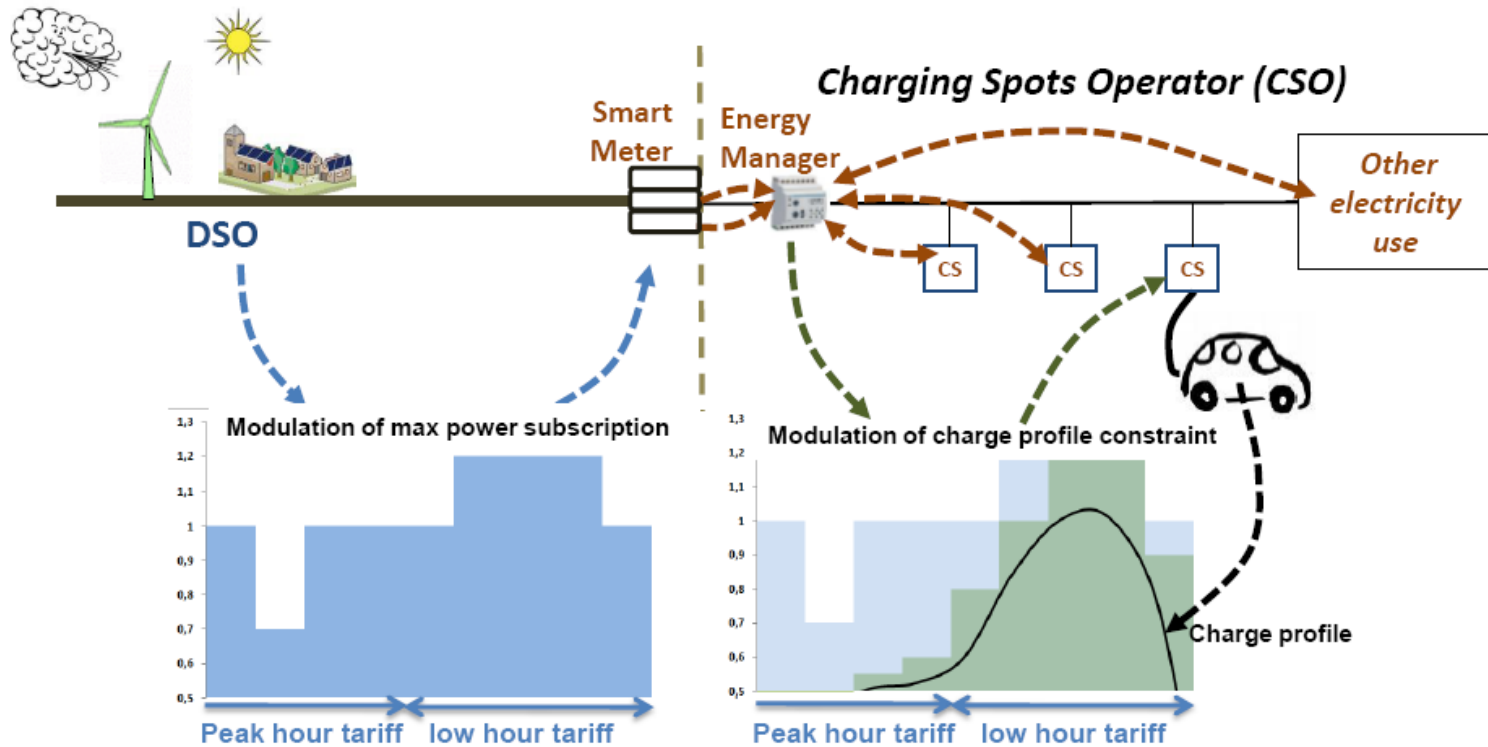

Charging process optimization

- ◆ DSO modulates (decrease or increase) max power subscription, in relation with flexibility operators, to avoid local network overload or to encourage consumption of available local renewable production.
- ◆ CSO's energy manager modulates charge profile constraint in relation with the price of electricity, the power subscription, and the other consumptions in its network (other e-cars to charge, other use, and their priorities).

Smart Charging Use Case

Simple solutions to start with:

- ▶ **Load control in low hour demand using clock or ripple control with dual tariff, if existing**
- ▶ **Direct payment of charging service including parking, if any**

More elaborated functions in a longer range:

- ▶ **With mode 3 plugging, communication between EV, Charging Spot, and Energy Manager enhances an accurate load profiling, promoting the Smart Grid development from DSO's side**
- ▶ **Service Payment of service can be made through data exchange between CSO and EMO.**



Summary

1. Current European context
2. Future challenges for the DSO
3. The INTER project in a nutshell
4. Focus on “Smart Charging” process
5. Final outline



© 2011 Médiathèque EDF

Final outline

- ▶ The arrival of EV is a **real opportunity for utilities but a huge challenge at the same time**
- ▶ Electric vehicles represent a **strong potential but will have a major impact for all stakeholders**: OEMs, utilities, service providers, municipalities,...
- ▶ **A stronger interaction and collaboration** will be required in the next years to come at a national and European level (harmonized standardization and policies)
- ▶ **Technical solutions should be kept simple and cost optimal** (most of the cases, the business model still remains to be clarified)
- ▶ As far as utilities are concerned, we have to set the path for the future arrival of mass market EVs, **becoming a key player** in the successful EV roll-outs and infrastructure planning

Thank you for your attention ! - Questions?



© 2011 Médiathèque EDF

gaizka.alberdi@edf.fr

ANNEX - I

Smart Charging Use Case Role Model:

- ▶ **Charging spot operator (CSO):** invest, maintain and operate charging spots.
- ▶ **E-mobility operator (EMO):** supply mobility service (car renting, car sharing, transportation, other e-mobility servicing...), possibly EV (or battery) owner.
- ▶ **Electrical system operator (DSO, TSO):** transmit energy down to the delivery point with the requested power and quality.
- ▶ **Distribution Meter Operator (DMO):** install and operate the Meter compliant with regulation for access to electricity supply market (often the same as DSO)
- ▶ **Electricity retailer (ESR):** sell energy on the market and supplies its customers.
- ▶ **Flexibility Operator (FLO):** aggregates load shaping of consumers on the request of TSO, DSO or Suppliers.
- ▶ **Other Service Operator (OSO):** covering other needs of drivers, such as parking management.